

Pickup Broom Series 2

Operation and Maintenance Manual



60" – 116512

72" – 116517

84" – 116522

96" – 116527

GUTTER BRUSH – 116555

Register your
WARRANTY
within 30 days
of purchase



888-376-7027 | BlueDiamondAttachments.com



BD-092

Introduction: Owner Information

Thank you for your decision to purchase a Blue Diamond® Series 2 Pickup Broom. To ensure maximum performance of your equipment, it is mandatory that you thoroughly study the Operator's manual and follow the recommendations. Proper operation and maintenance are essential to maximize equipment life and prevent personal injury.

Operate and maintain this equipment in a safe manner and in accordance with all applicable local, state, and federal codes, regulations and /or laws. Follow all on-product labeling and instructions.

Make sure that all personnel have read this Operator's Manual and thoroughly understand safe and correct operating, installation and maintenance procedures.

Blue Diamond is continually working to improve its products. Blue Diamond reserves the right to make any improvements or changes as deemed practical and possible without incurring any responsibility or obligation to make any changes or additions to equipment sold previously.

Although great care has been taken to ensure the accuracy of this publication, Blue Diamond makes no warranty or guarantee of any kind, written or expressed, implied or otherwise with regard to the information contained within this manual. Blue Diamond assumes no responsibility for any errors that may appear in this manual and shall not be liable under any circumstances for incidental, consequential or punitive damages in connection with, or arising from the use of this manual.

Keep this manual available for frequent reference. All new operators or owners must review the manual before using the equipment and annually thereafter. Contact your Blue Diamond Attachments Dealer for assistance, information, or additional copies of the manual. Contact www.bluediamondattachments.com or call 888-376-7027 for a complete list of dealers in your area.

Serial Number Location:

Please record attachment information in the space provided for future reference.



Model Number: _____

Serial Number: _____

Dealer Name: _____

Dealer Number: _____

Date of Purchase: _____

The serial number plate is located on the right side, just forward of the attachment mounting plate.

Always use your serial number when requesting information or when ordering parts.

NOTE: The directions left, right, front and rear, as mentioned throughout this manual, are as viewed from the operator's position.

Table of Contents

1. Safety	4-5
1.1 General Safety Information.....	4
1.2 Qualified Operators.....	5
1.3 Mandatory Safety Shutdown Procedure	5
2. Operation	6-8
2.1 Setup.....	6
2.2 Operating Tips.....	7
3. Maintenance	9-10
3.1 General	9
3.2 Lubrication.....	9
3.3 Checking & Adjusting Broom Pattern.....	9
3.4 Broom Wafers	10
3.5 Removing and Replacing Motor	10
3.6 Removing and Replacing Bearing.....	10
4. Parts.....	11-24
4.1 Main Parts Breakdown	11
4.2 Main Hood Breakdown.....	13
4.3 Adjustments	15
4.4 Stopping and Disconnecting	16
4.5 Transporting.....	17
4.6 Start Up	18
4.7 Operation Instructions.....	19
4.8 Adjustments	21
4.9 Stopping and Disconnecting	22
4.10 Transporting.....	24
5. Specifications	25
5.1 Torque Specifications.....	25
6. Warranty	27

1. Safety

1.1 General Safety Information



This **SAFETY ALERT SYMBOL** identifies important safety messages on the equipment and in the owner's manual. When you see this symbol, be alert to the possibility of personal injury and carefully read the message that follows.



The signal word **IMPORTANT** identifies procedures which must be followed to avoid damage to the machine.



The signal word **DANGER** on the machine and in the manuals indicates a hazardous situation which, if not avoided, will result in death or serious injury.



The signal word **WARNING** on the machine and in the manuals indicates a potentially hazardous situation which, if not avoided, could result in death or serious injury.



The signal word **CAUTION** on the machine and in the manuals indicates a potentially hazardous situation which, if not avoided, may result in minor or moderate injury. It may also be used to alert against unsafe practices.

- Read and follow instructions in this manual and the machine's Operators Manual before operating.
- The manual must always remain with the machine. In case of loss or damage, request a new copy from your dealer or from Blue Diamond.
- Strictly follow all rules prescribed by the safety pictograms/decals applied to the machine. Ensure that all safety pictograms/decals are legible. If pictograms/decals are worn, they must be replaced with new ones obtained from Blue Diamond and placed in the position indicated by this manual.
- Pay maximum attention to avoid any accidental contact with rotating parts of the machine.
- During operation, adjustment, maintenance, repairing, or transportation of the machine, the operator must always use appropriate Personal Protective Equipment (PPE) including but not limited to safety glasses, gloves, and hearing protection.
- Do not operate the attachment or machine while wearing loose fitting clothing that can be entangled or caught in parts of the machine.
- Do not operate the implement when tired, not in good condition, or under the influence of alcohol or drugs.

Entering and Leaving the Operator's Position

Get on or off the loader only at locations equipped with hand holds and steps. Keep the steps and handholds clean and inspect for damage. Make necessary repairs as needed.

Maintain 3 point contact and face the loader and attachment when entering and leaving.

DO NOT get on a moving or operating loader or attachment.

NEVER jump on or off a running loader or attachment.

1. Safety

1.2 Qualified Operators

Safe Operation Needs Qualified Operators



AVOID SERIOUS INJURY OR DEATH

Operators must receive instructions before operating the machine. Untrained operators can cause serious injury or death.

For an operator to be qualified, he or she must not use drugs or alcoholic drinks which impair alertness or coordination while working. An operator who is taking prescription drugs must get medical advice to determine if he or she can safely operate a machine and the equipment.

Operator Training

- Check the rules and regulations at your location. The rules may include an employer's work safety requirements. Regulations may apply to local driving requirements or use of a Slow Moving Vehicle (SMV) emblem. Regulations may identify a hazard such as a utility line.
- The new operator must start in an area without bystanders and use all the controls until he or she can operate the machine safely under all conditions of the work area.

1.3 Mandatory Safety Shutdown Procedure



Before operating this equipment, read and understand all information in this manual and the machine operator's manual. Each individual working with the equipment should be familiar with all safety precautions.



Failure to follow the safety procedures before cleaning, adjusting, lubricating, or servicing this unit could result in serious injury or death.

BEFORE cleaning, adjusting, lubricating, or servicing this unit, **ALWAYS** follow the **MANDATORY SAFETY SHUTDOWN PROCEDURE:**

1. Lower loader arms and roll attachment forward until it is flat on level ground.
2. Apply loader parking brake and stop the loader engine.
3. Cycle controls to relieve pressure within the auxiliary hydraulics lines.
4. Remove loader key and keep with you while working on the attachment.
5. Disconnect auxiliary hydraulic lines from loader.

2. Operation

2.1 Setup



WARNING



The following precautions must be observed for the safety of the operator and bystanders.

Although the broom attachment is supplied fully assembled, some simple checks should be performed before operation begins.

Safety Decals

The safety decals existing on the attachment should be clearly readable and always followed.

Hydraulic Couplers

The broom may have been shipped without the required hydraulic quick couplers. Obtain the correct brand and size and install them on the hoses.

Hoses / Fittings

Hydraulic fittings are used to connect all attachment hoses. All fittings should be tight and free of leaks. Hoses must be free of crimps or cuts that might result in leakage. Check your attachment before operation to make sure all hose routings are kink-free and allow for movement during the sweeping and dumping operations.

Wire Harness

The wiring harness to the optional water spray kit pump should be routed to prevent catching or pinching during the sweeping and dumping operations.

Connecting Attachment to the Machine



WARNING



Never crawl under raised loader arms or attachment.

To attach the broom to the loader:

1. Start the loader engine and rotate the coupler out. Retract the coupler pins.
2. Move the loader forward and align the coupler between the outer mounting bracket plates. Pick up the attachment with the top bar.
3. Rotate the attachment back and engage the coupler pins. Ensure coupler pins are completely down and engaged. Always refer to operating instructions in the skid steer manual.
4. Engage loader parking brake and stop the engine. Cycle the controls to remove pressure in the auxiliary hydraulic lines. Exit loader.
5. Clean quick couplers if dirty. Connect hydraulic hoses to the skid steer quick couplers.

NOTE: While attachment is on the ground, visually inspect quick coupler to ensure pins are extended.

6. Connect the wiring harness.

Safe Broom Operation

- Always follow the safety and operating information in this manual.
- Only operate the attachment from the seat of the loader.
- Always follow the weight limitations of the loader.
- Do not remove guards and shields.
- Do not sweep near or toward people, vehicles, or buildings that may be injured or damaged by flying debris.
- Wear eye protection around the attachment.
- Carry the attachment low to the ground.
- **DO NOT** carry passengers.

2. Operation

2.2 Operating Tips

Sweeping

Only use broom on compatible loaders. Loader flow must not exceed 25 gallons per minute. DO NOT USE high flow hydraulics. Loader relief pressure must not exceed 3500 PSI. Consult loader manual for flow and pressure specifications.

Do not engage the broom hydraulics with the loader engine at high speed. Engage hydraulics at low engine speed and gradually increase engine speed.

Do not reverse sweeping direction without stopping broom hydraulics.

Limit forward and reverse travel speed to 5 mph.

Adjust brush to give a 2"- 4" wide pattern. (See maintenance section)

Adjust rubber front and side skirts to be within 1/2" of the ground.

Slow down in heavy material. Allow time for the broom to sweep.

Avoid excessive down pressure on the broom.

Carry bucket so bolt-on edge is 1" above ground line. Bucket should not contact ground, only broom.

When sweeping forward, rotate the brush so material is pushed away from the loader and over the broom into the bucket. See Figure 1.

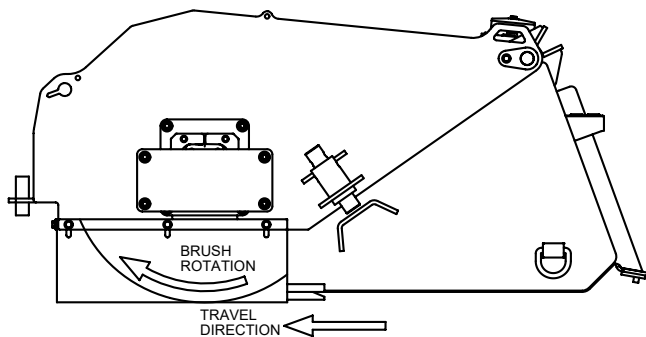

Figure 1

When sweeping backward, rotate the brush so material is pushed toward the loader and into the bucket. See Figure 2.

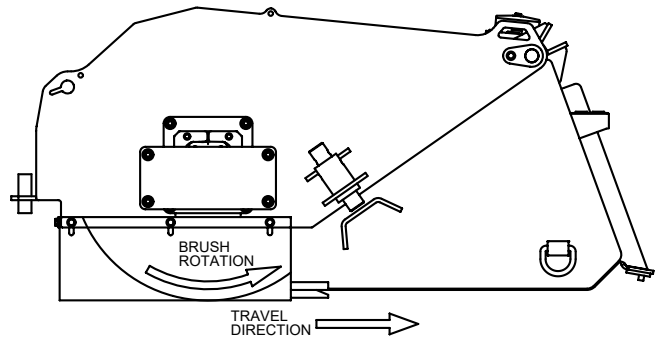

Figure 2

Dumping



WARNING



The following precautions must be observed for the safety of the operator and bystanders.

STAY AWAY FROM POWER LINES.

Always check clearances before lifting broom.

Carry loaded bucket low to dump site.

Raise bucket slowly to the required dump height, roll broom forward to dump bucket.

Optional Water Kit

Check the strainer bowl daily for dirt and debris. This debris can plug the nozzles.

Check nozzles daily for debris. Remove and clean plugged nozzles.

2. Operation

2.2 Operating Tips Cont'd

Optional Gutter Brush Kit

Only use gutter brush in forward direction.

Adjust height using retention chain so the gutter brush bristle tips are touching the ground.

When not in use for a short period of time, raise the gutter brush 1 – 2” above the ground with the retention chain. Use the shut-off valve to stop bristle rotation when the gutter brush is raised.

When not in use for long periods of time, remove the gutter brush and connect the primary broom motor directly to the loader hydraulics.

Storage

Follow the loader manufacturer's instructions to remove the broom attachment.

DO NOT store the polypropylene brush wafers in direct sun light. The material can deteriorate.

Raise broom housing and take weight off of broom wafers. Store broom with bucket stop pins in the lowest position to relieve ground pressure on broom core.

3. Maintenance

3.1 General



WARNING



The following precautions must be observed for the safety of the operator and bystanders.

Proper maintenance of the attachment will result in longer life and more productive and cost effective operation. There are two basic categories of maintenance, lubrication, and broom wafer maintenance.

3.2 Lubrication

Grease the following lube points weekly. Lubricate all grease zerks with an EP Lithium NLGL No. 2 grade grease. One example is Mobilux EP2.

- Broom shaft bearing zerk. This zerk is located on the right side of the broom shroud. It can be accessed through the wafers.
- Broom shroud pivot zerks. These two zerks are located at the top rear of each side of the bucket and should be greased weekly.
- Right side bearing. These two zerks are located on the bearing located on the right side of the broom. Grease either of the two zerks, both do not need to be greased.

3.3 Checking and Adjusting Broom Pattern

The brush pattern should be checked and adjusted every 8 hours or daily. To check and adjust pattern:

1. Move the broom to a dusty flat surface.
2. With the loader at low throttle, start the broom motor.
3. Slowly lower the broom until it is in the operating position. (bolt-on edge is 1" off of ground).
4. Keep the broom in this position for 10 seconds. Do not move loader.
5. Raise broom, stop the broom motor, and move the loader back several feet. Lower broom to ground, set loader brake and exit loader.

6. Measure pattern width left by broom. Pattern should be 2"–4" wide.
7. To adjust pattern, carefully prop up the broom shroud assembly. Remove the two bent leg pins.
8. Move the two stop pins to a different hole location and replace the two bent pins. To widen the pattern move the stop pins up; to narrow the pattern move the stop pins down. See Figure 3.

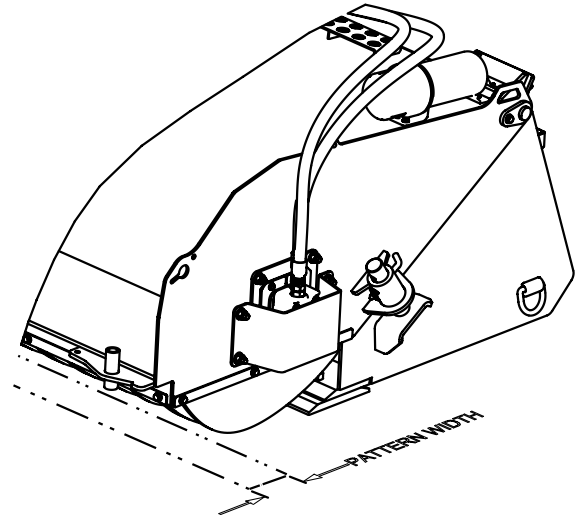

Figure 3

3. Maintenance

3.4 Broom Wafers

Removing Broom Wafers

See parts diagram for pictures.

1. Place broom on ground and perform mandatory shutdown procedure (see section 1.3 Mandatory Safety Shutdown Procedure on page 3).
2. Remove side rubber skirt retainers.
3. Remove motor guard hardware and motor guard plate.
4. Remove bearing guard hardware and bearing guard plate.
5. Remove motor plate to broom housing hardware and remove motor subassembly.
6. Remove bearing plate to broom housing hardware.
7. Using hoist, raise broom housing off of broom core. Roll broom core away from bucket.
8. Remove end retainer from one broom core end.
9. Remove wafers.

Replacing Broom Wafers

See parts diagram for pictures.

1. Place broom drum on end with one retaining plate assembled. Place retaining plate on ground.
2. Install a new wafer making sure wafer retention pins are trapped on broom drum bar.
3. Install more wafers. Alternate steel and poly wafers if using both types. The retention pins on consecutive wafers should alternate 180° and be trapped by opposite bars.
4. Install last wafer and install broom drum retaining plate. Carefully lay the core on its side.
5. Move core under broom housing and lower housing on core.
6. Replace bearing plate and motor plate hardware. Tighten hardware.
7. Replace motor and bearing guard plates and hardware. Tighten hardware.
8. Reinstall rubber skirting and side skirting retainers.
9. Tighten hardware.

3.5 Removing and Replacing Motor

See parts diagram for pictures.

1. Place broom the ground and perform mandatory shutdown procedure (see section 1.3 Mandatory Safety Shutdown Procedure on page 3).
2. Remove left side rubber skirt retainer.
3. Remove and cap motor hoses.
4. Remove motor guard hardware and motor guard plate.
5. Remove motor subassembly from broom housing.
6. Remove coupler bolt and loosen coupler set screw. Remove coupler from motor shaft.
7. Remove motor gasket plate hardware, gasket plates, and gasket.
8. Remove motor can hardware and remove motor.
9. Reassemble in reverse order.

3.6 Removing and Replacing Bearing

See parts diagram for pictures.

1. Place broom the ground and perform mandatory shutdown procedure (see section 1.3 Mandatory Safety Shutdown Procedure on page 3).
2. Remove right side rubber skirt retainer.
3. Remove bearing guard hardware and bearing guard plate.
4. Remove bearing plate to broom housing hardware.
5. Loosen bearing lock collar with a drift punch and hammer. Counter clockwise loosens collar.
6. Remove bearing and bearing plate.
7. Remove bearing plate to bearing hardware to remove bearing.
8. Reassemble in reverse order. To tighten bearing lock collar, use hammer and drive punch. Clockwise movement tightens collar.

4. Parts

4.1 Main Parts Breakdown

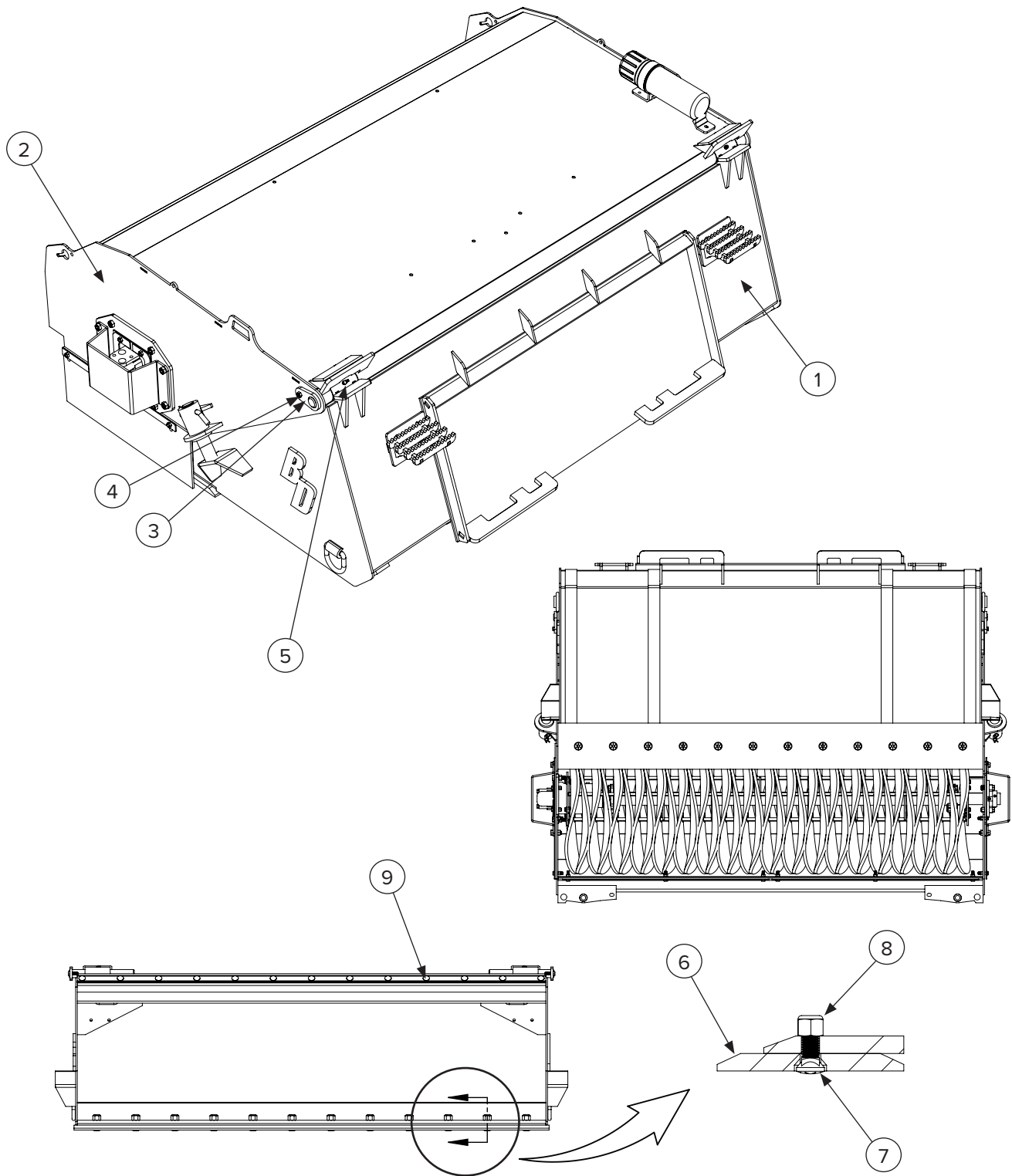

4. Parts

4.1 Main Parts Breakdown Cont'd

ITEM	PART NUMBER	DESCRIPTION	QTY 60" 316580	QTY 72" 316538	QTY 84" 316586	QTY 96" 316589
1	216370-60	Bucket Weldment - 60"	1	—	—	—
	216380-60*					
	216370-72	Bucket Weldment - 72"	—	1	—	—
	216380-72*					
	216370-84	Bucket Weldment - 84"	—	—	1	—
	216380-84*					
	216370-96	Bucket Weldment - 96"	—	—	—	1
	216380-96*					
2	216371-60	Hood Weldment - 60"	1	—	—	—
	216381-60*					
	216371-72	Hood Weldment - 72"	—	1	—	—
	216381-72*					
	216371-84	Hood Weldment - 84"	—	—	1	—
	216381-84*					
	216371-96	Hood Weldment - 96"	—	—	—	1
	216381-96*					
3	216465	Hood Pivot Pin	2	2	2	2
4	299426	3/8 x 1 1/4" Bolt	2	2	2	2
5	299016	Pivot Grease Fitting	2	2	2	2
	297005*	Pivot Grease Fitting	2	2	2	2
6	216560	Bolt-On Edge - 60"	1	—	—	—
	216562	Bolt-On Edge - 72"	—	1	—	—
	216564	Bolt-On Edge - 84"	—	—	1	—
	216566	Bolt-On Edge - 96"	—	—	—	1
7	216570	3/4 x 2" Plow Bolt	10	12	14	16
8	299657	3/4" Nylock Nut	10	12	14	16
9	216375	Black Push-In Rivets for 3/8" Hole	11	13	15	17
* For serial numbers 144361, 151397, 151398, 151839-151844, 153113						

4. Parts

4.2 Main Hood Breakdown

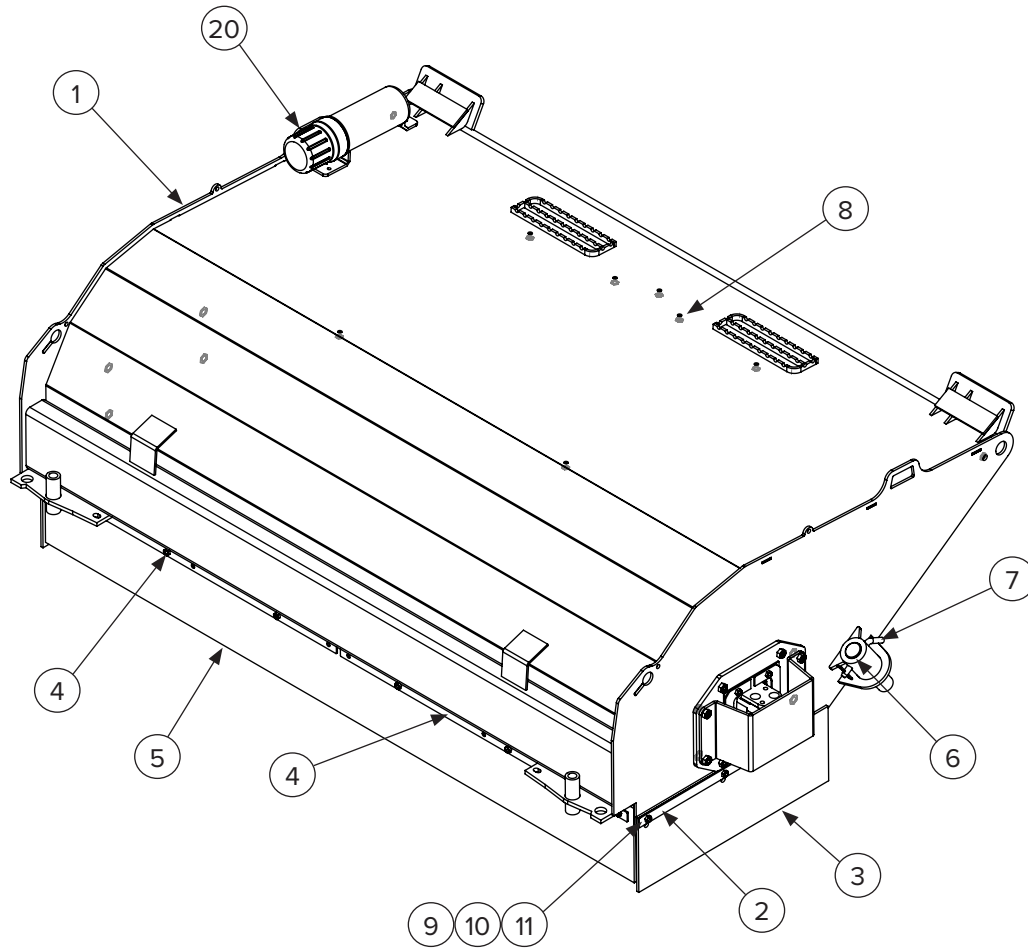

4. Parts

4.2 Main Hood Breakdown Cont'd

ITEM	PART NUMBER	DESCRIPTION	QTY 60" 316580	QTY 72" 316538	QTY 84" 316586	QTY 96" 316589
1	216371-60	Hood Weldment - 60"	1	—	—	—
	216381-60*					
	216371-72	Hood Weldment - 72"	—	1	—	—
	216381-72*					
	216371-84	Hood Weldment - 84"	—	—	1	—
	216381-84*					
	216371-96	Hood Weldment - 96"	—	—	—	1
	216381-96*					
2	216450	Side Skirt Retainer Plate	2	2	2	2
3	216451	Side Skirt	2	2	2	2
4	216452	Front Skirt Retainer Plate - 60"	2	2	2	2
	216454	Front Skirt Retainer Plate - 72"	2	2	2	2
	216456	Front Skirt Retainer Plate - 84"	2	2	2	2
	216458	Front Skirt Retainer Plate - 96"	2	2	2	2
5	216453	Front Skirt - 60"	1	1	1	1
	216455	Front Skirt - 72"	1	1	1	1
	216457	Front Skirt - 84"	1	1	1	1
	216459	Front Skirt - 96"	1	1	1	1
6	216462	Pivot Stop Pin	2	2	2	2
7	216573	Bent Pull Clevis Pin	2	2	2	2
8	299423	Hood bolts - 3/8 x 1"	7	7	7	7
9	299426	Skirt Bolt - 3/8 x 1.25"	12	12	14	14
10	299724	Skirt Washer	12	12	14	14
11	299625	Skirt nut - 3/8" Nylock	12	12	14	14
* For serial numbers 144361, 151397, 151398, 151839-151844, 153113						

4. Parts

4.3 Bearing Mount Breakdown

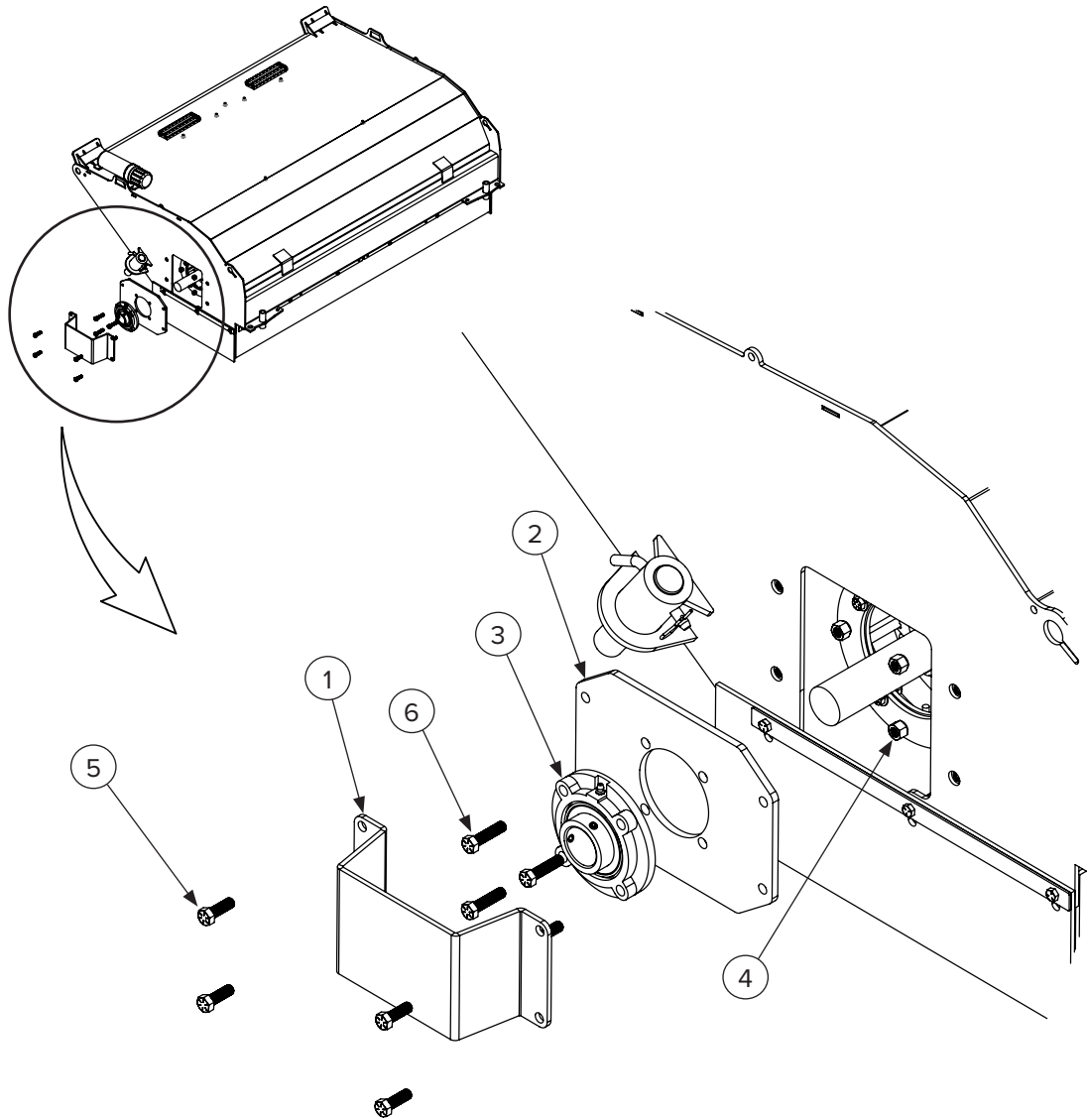

ITEM	PART NUMBER	DESCRIPTION	QTY
1	216372	Cover - Square Bearing	1
	216382*	Cover - Round Bearing	1
2	216373	Bearing Mount Plate - Square Bearing	1
	216383*	Bearing Mount Plate - Round Bearing	1
3	216590	Bearing - Square	1
	216479*	Bearing - Round	1
4	109177	Bearing Nuts - Square Bearing - 5/8" Stover	4
	299618*	Bearing Nuts - Round Bearing - 1/2" Nylock	4
5	299432	Cover Bolts - Square Bearing - 1/2 x 1.5"	4
	299439*	Cover Bolts - Round Bearing - 1/2 x 1.75"	4
6	299440	Bearing Bolts - Square Bearing - 5/8 x 1.75"	4
	299433-2.25*	Bearing Bolts - Round Bearing - 1/2 x 2.25"	4
* For serial numbers 144361, 151397, 151398, 151839-151844, 153113			

4. Parts

4.4 Motor Mount Breakdown

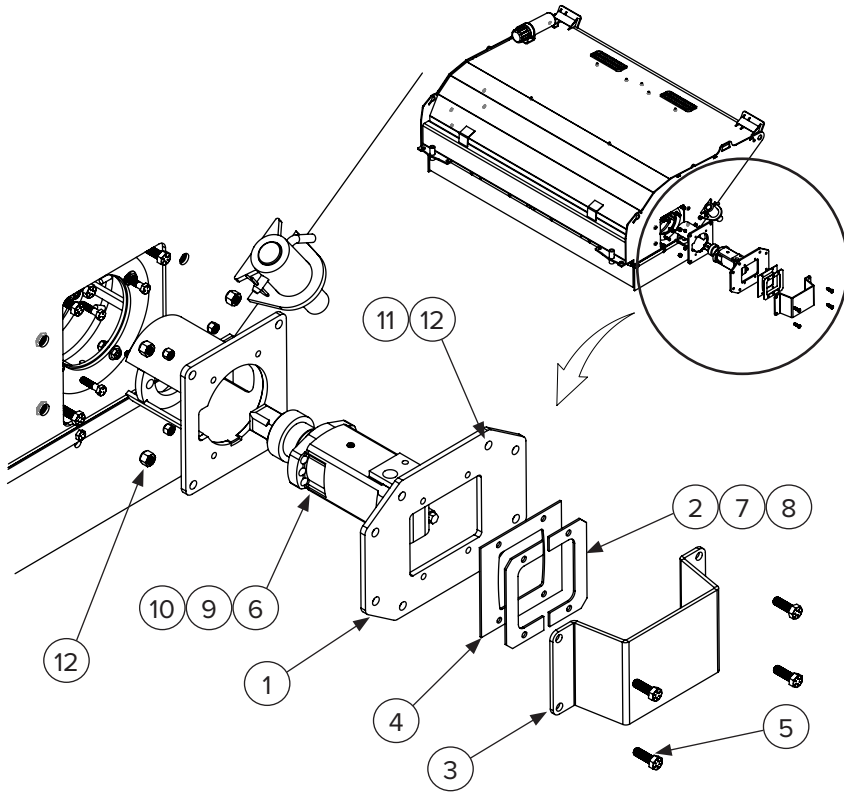

ITEM	PART NUMBER	DESCRIPTION	QTY
1	216374	Left Side Motor Mount Plate	1
	216384*		
2	216377	Rubber Cover Retaining Plate	2
3	216372	Motor Cover	1
	216382*		
4	216376	Rubber Motor Cover	1
5	299432	Motor Cover Bolts - 1/2 x 1.5"	4
	299439*	Motor Cover Bolts - 1/2 x 1.75"	4
6	299618	Motor Mount Nut - 1/2" Nylock	2
7	299487	Rubber Motor Cover Bolts - 3/8 x 1.5"	4
8	299625	Rubber Motor Cover Nuts - 3/8" Nylock	4
9	299433	Motor Mount Bolt - 1/2 x 2"	2
	299433-2.25*	Motor Mount Bolt - 1/2 x 2.25"	2
10	See "Motor Assembly"	Motor Assembly	1
11	299487	Motor Coupler Bolts - 3/8 x 1.5"	4
	299439*	Motor Coupler Bolts - 1/2 x 1.75"	
12	299625	Motor Coupler Nuts - 3/8 Nylock	4
	299618*	Motor Coupler Nuts - 1/2 Nylock	
* For serial numbers 144361, 151397, 151398, 151839-151844, 153113			

4. Parts

4.5 Drum Shaft Breakdown

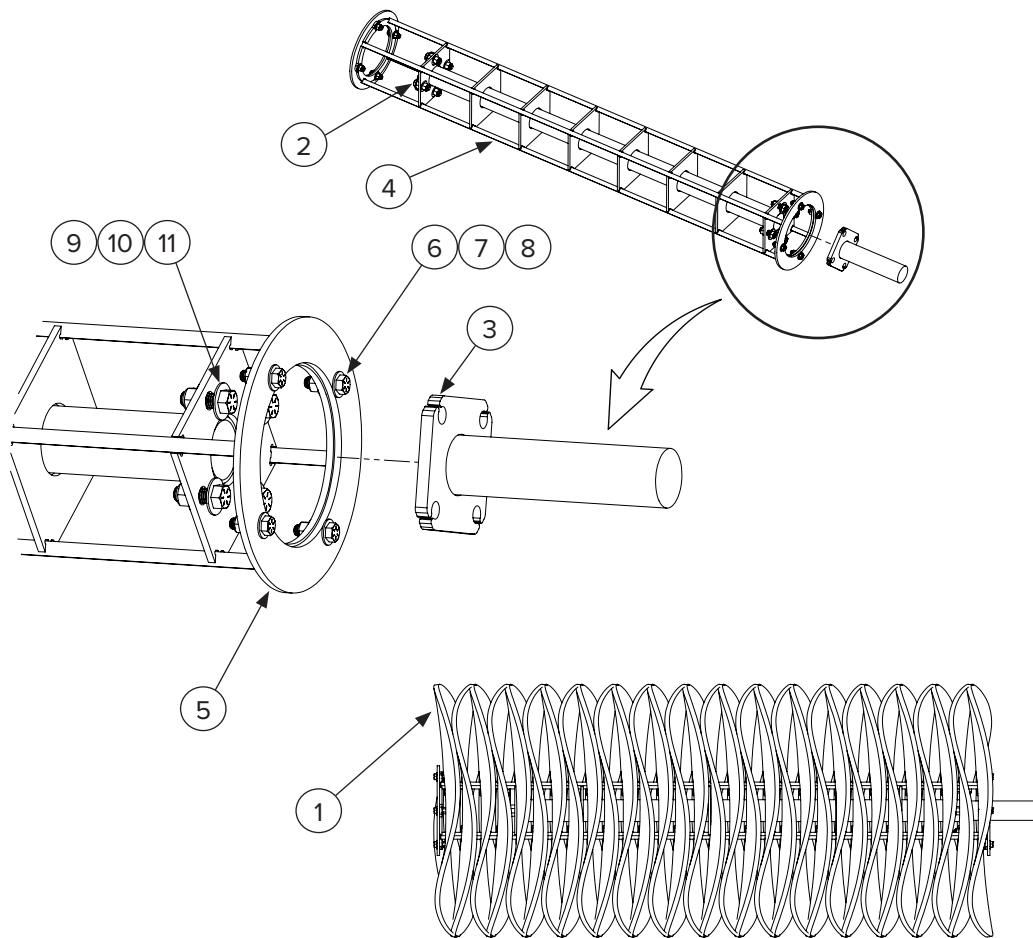

ITEM	PART NUMBER	DESCRIPTION	QTY 60" 316580	QTY 72" 316538	QTY 84" 316586	QTY 96" 316589
1	216415	Wafer - Poly	31	37	43	49
	216410	Wafer - Steel				
	216417	Wafer - Poly/Steel				
2	216478	Motor to Shaft Flange	1	1	1	1
3	216480	Drum to Bearing Shaft and Flange	1	1	1	1
4	216481	Drum Shaft - 60"	1	—	—	—
	216482	Drum Shaft - 72"	—	1	—	—
	216483	Drum Shaft - 84"	—	—	1	—
	216484	Drum Shaft - 96"	—	—	—	1
5	216378	Bristle Retaining Ring	1	1	1	1
6	299426	Retaining Ring Bolts - 3/8 x 1.25"	8	8	8	8
7	299625	Retaining Ring Nuts - 3/8" Nylock	8	8	8	8
8	299724	Retaining Ring Washers	16	16	16	16
9	299432	Flange Bolts - 1/2 x 1.5"	8	8	8	8
10	299618	Flange Nuts 1/2" Nylock	8	8	8	8
11	299732	Flange Washers	16	16	16	16

4. Parts

4.6 Motor Assembly

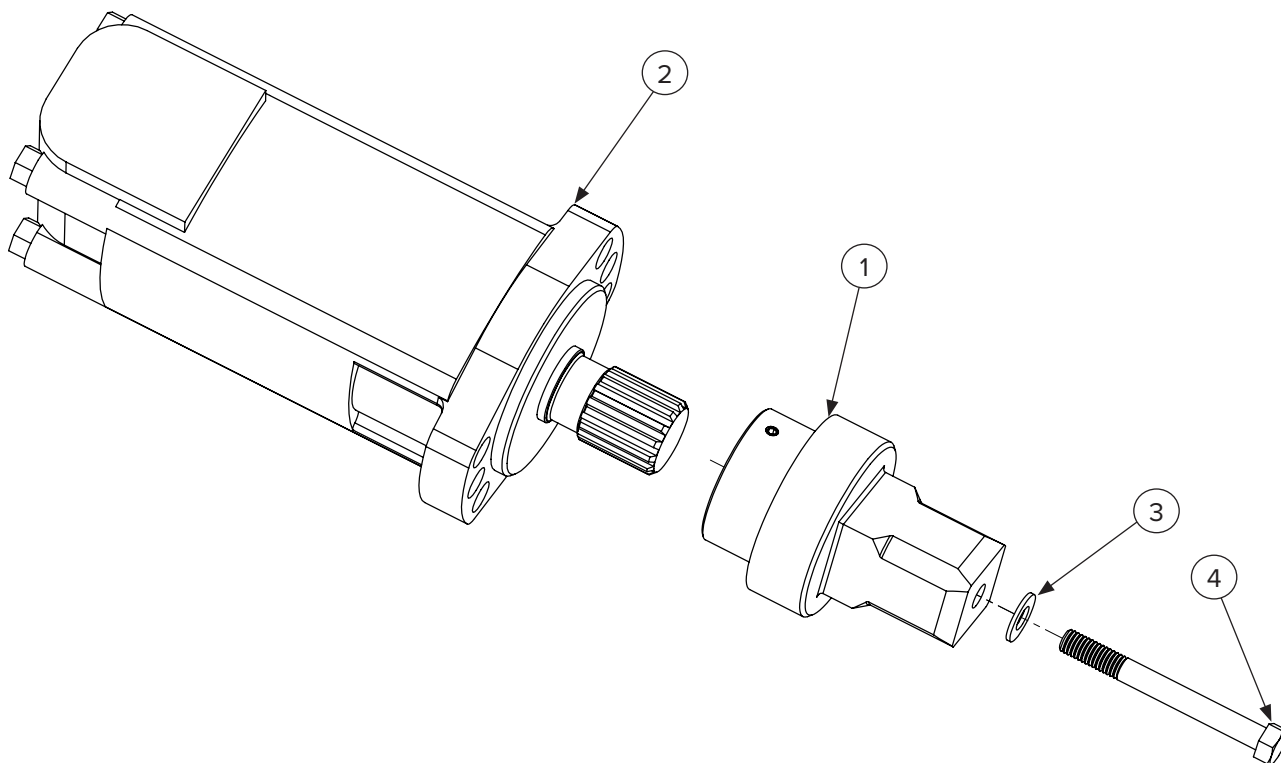

ITEM	PART NUMBER	DESCRIPTION	QTY
1	216421-2	Motor Shaft Coupler	1
	216386*		1
2	216425	Motor	1
	216385*		1
3	299724	Motor Coupler Washer	1
	N/A*		—
4	299447	Motor Coupler Bolt - 3/8 x 4"	1
* For serial numbers 144361, 151397, 151398, 151839-151844, 153113			

4. Parts

4.7 Water Kit Breakdown

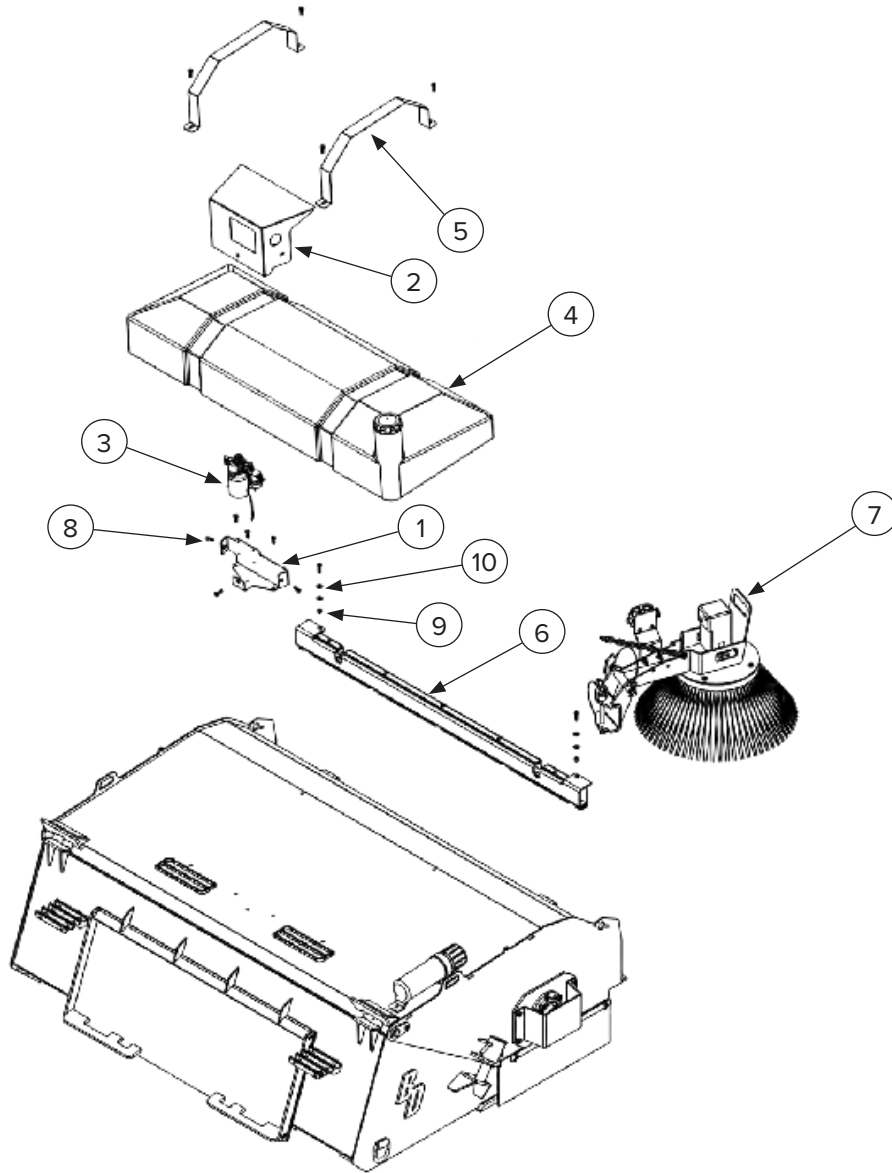

316571	60" Water Kit
316573	72" Water Kit
316576	84" Water Kit
316579	96" Water Kit

4. Parts

4.7 Water Kit Breakdown Cont'd

ITEM	PART NUMBER	DESCRIPTION	QTY
1	216673	Pump Mount Bracket	1
2	216539	Pump Hood	1
3	216540	Pump	1
4	216650	Pub Tank	1
5	216655	Tank Strap	2
6	316580	60" Spray Bar Kit	1
	316583	72" Spray Bar Kit	
	316586	84" Spray Bar Kit	
	316589	96" Spray Bar Kit	
7	116555	Gutter Brush Assembly	1
8	299426	Hex Bolt-Grade 8-3/8-16 X 1	2
9	299625	Grade 8 Locknut 3/8-16	2
10	299725	Washer 3/8	2
NS	216688	1/2 Water Hose (per foot)	9

4. Parts

4.8 Spray Bar Kit Breakdown

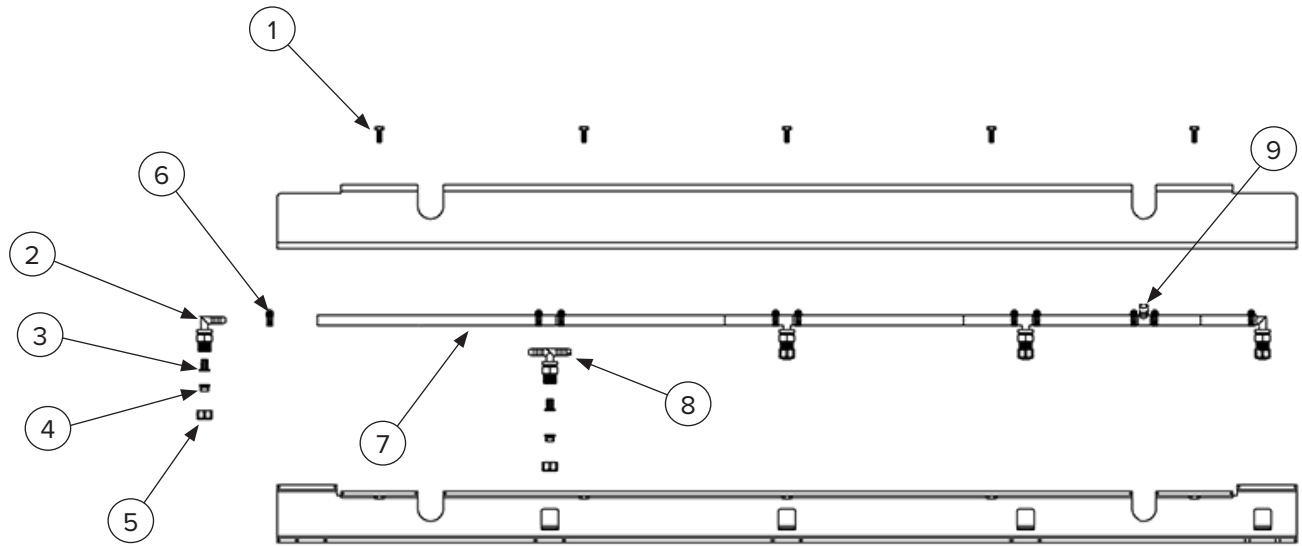

ITEM	PART NUMBER	DESCRIPTION	QTY 60" 316580	QTY 72" 316538	QTY 84" 316586	QTY 96" 316589
1	299426	Hex Bolt-Grade 8-3/8-16 X 1	5	5	7	7
2	216310	Barbed 90° Fitting	2	2	2	2
3	216320	Strainer	4	5	6	7
4	216305	Nozzle	4	5	6	7
5	216693	Nozzle Retainer Nut	4	5	6	7
6	216691	Hose Crimp	8	10	12	14
7	216690	Water Kit Hose	1	1	1	1
8	216315	Nozzle Tee Fitting	2	3	4	5
9	216694	Barbed Tee Fitting	1	1	1	1

4. Parts

4.9 Gutter Brush Breakdown

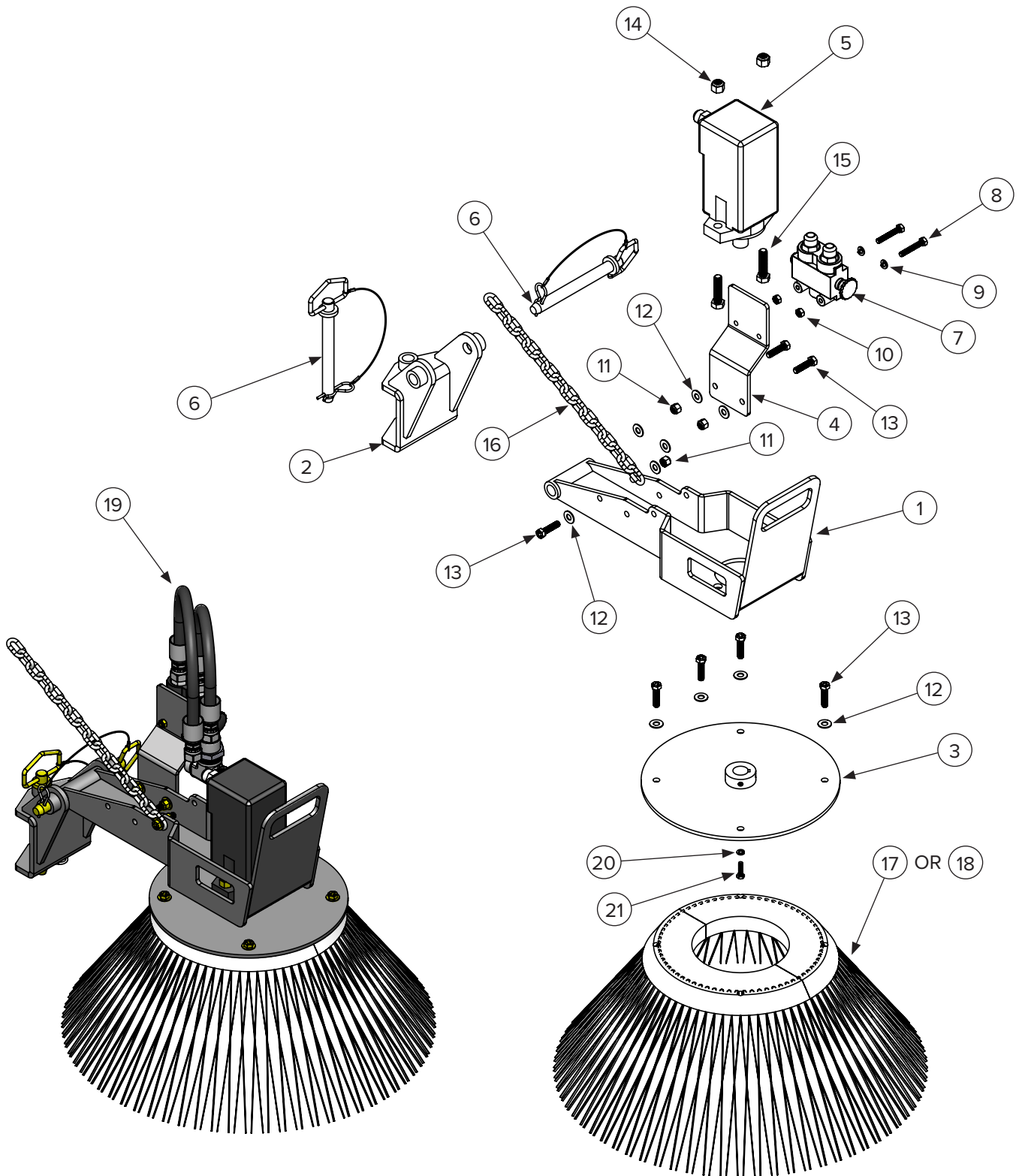

4. Parts

4.9 Gutter Brush Breakdown Cont'd

ITEM	PART NUMBER	DESCRIPTION	QTY
1	216620	Arm — Weldment	1
2	216622	Mount — Weldment	1
3	216615	Hub — Weldment	1
4	216625	Diverter Mount	1
5	216585	Motor	1
6	216621	Clevis Pin — Ø3/4" X 6 1/4" U.L.	2
7	216630	Shut off Valve	1
8	299319	Grade 8 — Hex Bolt — 5/16-18 X 2.0	2
9	299815	Lock Washer — 5/16	2
10	299571	Grade 8 — Hex Nut — 5/16-18	2
11	299625	Locknut, 3/8-16 Grade 8	3
12	299725	Washer — 3/8	8
13	299428	Hex Bolt — Grade 8 — 3/8-16 X 1.5	7
14	299618	Locknut — Gr 8 — 1/2-13	2
15	299433	Hex Bolt — Grade 8 — 1/2-13 X 2.00	2
16	216623	Chain	1
17	216605	Bristle — Poly	2
18	216600	Bristle — Steel	
19	216524	Hose — Motor to Shut off Valve	2
20	299810	Lock Washer — 1/4	1
21	299418-1	Hex Bolt — Grade 8 — 1/4"-20 X 1	1

4. Parts

4.10 Hoses Breakdown

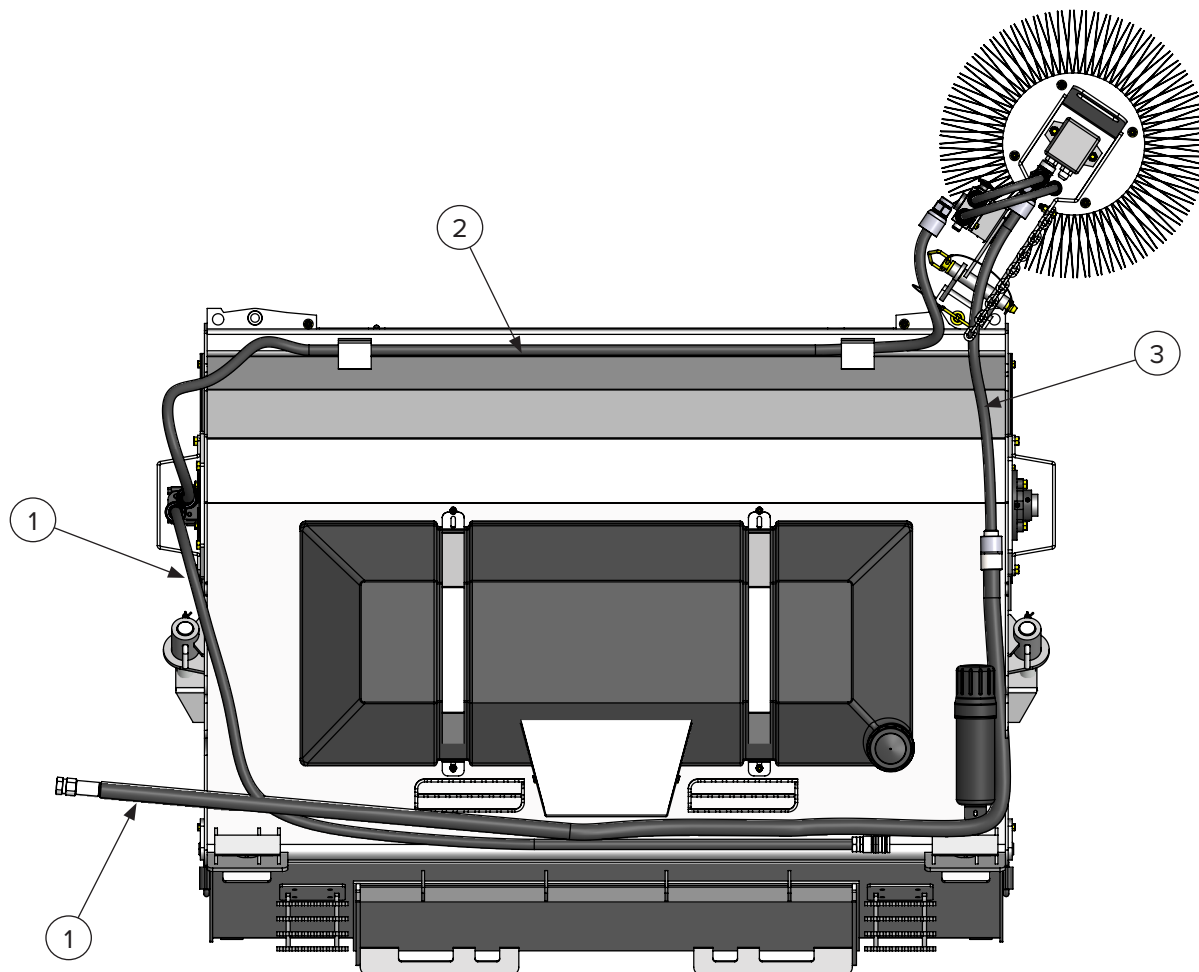

ITEM	PART NUMBER	DESCRIPTION	QTY
1	216518	Machine Side Hose Set fits 60" & 72" (no couplers); requires 1/2" O-Ring Couplers	1
	216519	Machine Side Hose Set fits 84" & 96" (no couplers); requires 1/2" O-Ring Couplers	
2	216520	Gutter Brush Long Extension Hose	1
3	216522	Gutter Brush Short Extension Hose	1

5. Specifications

5.1 Torque Specifications

Standard Hardware and Lock Nuts

BOLT TYPE	SAE GRADE 5		SAE GRADE 8		LOCK NUTS			
	Nominal Size	Plated or Unplated Silver	Plated W/ ZnCr Gold	Plated or Unplated Silver	Plated W/ ZnCr Gold	Plated or Unplated Silver	Plated W/ ZnCr Gold	W/ Grade 5 Bolt
1/4	55 in / lb (6.2 N•m)	72 in / lb (8.1 N•m)	86 in / lb (9.7 N•m)	112 in / lb (12.6 N•m)	121 in / lb (13.6 N•m)	157 in / lb (17.7 N•m)	61 in / lb (6.9 N•m)	86 in / lb (9.8 N•m)
5/16	115 in / lb (13 N•m)	149 in / lb (17 N•m)	178 in / lb (20 N•m)	229 in / lb (26 N•m)	250 in / lb (28 N•m)	325 in / lb (37 N•m)	125 in / lb (14 N•m)	176 in / lb (20 N•m)
3/8	17 ft / lb (23 N•m)	22 ft / lb (30 N•m)	26 ft / lb (35 N•m)	34 ft / lb (46 N•m)	37 ft / lb (50 N•m)	48 ft / lb (65 N•m)	19 ft / lb (26 N•m)	26 ft / lb (35 N•m)
7/16	27 ft / lb (37 N•m)	35 ft / lb (47 N•m)	42 ft / lb (57 N•m)	54 ft / lb (73 N•m)	59 ft / lb (80 N•m)	77 ft / lb (104 N•m)	30 ft / lb (41 N•m)	42 ft / lb (57 N•m)
1/2	42 ft / lb (57 N•m)	54 ft / lb (73 N•m)	64 ft / lb (87 N•m)	83 ft / lb (113 N•m)	91 ft / lb (123 N•m)	117 ft / lb (159 N•m)	45 ft / lb (61 N•m)	64 ft / lb (88 N•m)
9/16	60 ft / lb (81 N•m)	77 ft / lb (104 N•m)	92 ft / lb (125 N•m)	120 ft / lb (163 N•m)	130 ft / lb (176 N•m)	169 ft / lb (229 N•m)	65 ft / lb (88 N•m)	92 ft / lb (125 N•m)
5/8	83 ft / lb (112 N•m)	107 ft / lb (145 N•m)	128 ft / lb (174 N•m)	165 ft / lb (224 N•m)	180 ft / lb (244 N•m)	233 ft / lb (316 N•m)	90 ft / lb (122 N•m)	127 ft / lb (172 N•m)
3/4	146 ft / lb (198 N•m)	189 ft / lb (256 N•m)	226 ft / lb (306 N•m)	293 ft / lb (397 N•m)	319 ft / lb (432 N•m)	413 ft / lb (560 N•m)	160 ft / lb (217 N•m)	226 ft / lb (306 N•m)
7/8	142 ft / lb (193 N•m)	183 ft / lb (248 N•m)	365 ft / lb (495 N•m)	473 ft / lb (641 N•m)	515 ft / lb (698 N•m)	667 ft / lb (904 N•m)	258 ft / lb (350 N•m)	364 ft / lb (494 N•m)
1	213 ft / lb (289 N•m)	275 ft / lb (373 N•m)	547 ft / lb (742 N•m)	708 ft / lb (960 N•m)	773 ft / lb (1048 N•m)	1000 ft / lb (1356 N•m)	386 ft / lb (523 N•m)	545 ft / lb (739 N•m)

**This page intentionally
left blank**



Warranty

MANUFACTURER'S LIMITED WARRANTY

BLUE DIAMOND® ATTACHMENTS, a manufacturer of quality attachments, warrants new BLUE DIAMOND® ATTACHMENTS products and/or attachments at the time of delivery to the original purchaser, to be free from defects in material and workmanship when properly set up and operated in accordance with the recommendations set forth by BLUE DIAMOND® ATTACHMENTS, LLC.

BLUE DIAMOND® ATTACHMENTS liability for any defect with respect to accepted goods shall be limited to repairing the goods at a BLUE DIAMOND® ATTACHMENTS designated location or at an authorized dealer location, or replacing them, as BLUE DIAMOND® ATTACHMENTS shall elect. The above shall be in accordance with BLUE DIAMOND® ATTACHMENTS warranty adjustment policies. BLUE DIAMOND® ATTACHMENTS obligation shall terminate twelve (12) months for the Series 2 Pickup Broom after the delivery of the goods to original purchaser.

This warranty shall not apply to any machine or attachment which shall have been repaired or altered outside the BLUE DIAMOND® ATTACHMENTS factory or authorized BLUE DIAMOND® ATTACHMENTS dealership or in any way so as in BLUE DIAMOND® ATTACHMENTS judgment, to affect its stability or reliability, nor which has been subject to misuse, negligence or accident beyond the company recommended machine rated capacity.

WARRANTY CLAIM

To submit a warranty claim, a claim must be filed with BLUE DIAMOND® ATTACHMENTS before work is performed. The BLUE DIAMOND® PRODUCT SUPPORT TEAM will advise repairs and applicable parts exchanges. Tampering with the failed part may void the warranty. This warranty does not include freight or delivery charges incurred when returning machinery for servicing. Dealer mileage, service calls, and pickup/delivery charges are the customers' responsibility.

EXCLUSIONS OF WARRANTY

Except as otherwise expressly stated herein, BLUE DIAMOND® ATTACHMENTS makes no representation or warranty of any kind, expressed or implied, AND MAKES NO WARRANTY OF MERCHANTABILITY IN RESPECT TO ITS MACHINERY AND/OR ATTACHMENTS ARE FIT FOR ANY PARTICULAR PURPOSE. BLUE DIAMOND® ATTACHMENTS shall not be liable for incidental or consequential damages for any breach or warranty, including but not limited to inconvenience, rental of replacement equipment, loss of profits or other commercial loss. Upon purchase, the buyer assumes all liability for all personal injury and property resulting from the handling, possession, or use of the goods by the buyer.

No agent, employee, or representative of BLUE DIAMOND® ATTACHMENTS has any authority to bind BLUE DIAMOND® ATTACHMENTS to any affirmation, representation, or warranty concerning its machinery and/or attachments except as specifically set forth herein.

This warranty policy supersedes any previous documents.

NOTE: Blue Diamond® Attachments is a trademark of BLUE DIAMOND® ATTACHMENTS



QUALITY | DEPENDABILITY | INTEGRITY

Blue Diamond® Attachments
4512 Anderson Road, Knoxville, TN 37918
888-376-7027