

84" Dual Spindle Brush Cutter

Operation and Maintenance Manual



Register your
WARRANTY
within 30 days
of purchase



888-376-7027 | BlueDiamondAttachments.com



BD-092

Introduction: Owner Information

Thank you for your decision to purchase a Blue Diamond® 84" Dual Spindle Brush Cutter. To ensure maximum performance of your equipment, it is mandatory that you thoroughly study the Operator's manual and follow the recommendations. Proper operation and maintenance are essential to maximize equipment life and prevent personal injury.

Operate and maintain this equipment in a safe manner and in accordance with all applicable local, state, and federal codes, regulations and /or laws. Follow all on-product labeling and instructions.

Make sure that all personnel have read this Operator's Manual and thoroughly understand safe and correct operating, installation and maintenance procedures.

Blue Diamond is continually working to improve its products. Blue Diamond reserves the right to make any improvements or changes as deemed practical and possible without incurring any responsibility or obligation to make any changes or additions to equipment sold previously.

Although great care has been taken to ensure the accuracy of this publication, Blue Diamond makes no warranty or guarantee of any kind, written or expressed, implied or otherwise with regard to the information contained within this manual. Blue Diamond assumes no responsibility for any errors that may appear in this manual and shall not be liable under any circumstances for incidental, consequential or punitive damages in connection with, or arising from the use of this manual.

Keep this manual available for frequent reference. All new operators or owners must review the manual before using the equipment and annually thereafter. Contact your Blue Diamond Attachments Dealer for assistance, information, or additional copies of the manual. Contact www.bluediamondattachments.com or call 888-376-7027 for a complete list of dealers in your area.

Serial Number Location:

Please record attachment information in the space provided for future reference.



Model Number: _____

Serial Number: _____

Dealer Name: _____

Dealer Number: _____

Date of Purchase: _____

The serial number plate is located on the top center of the mounting plate.

Always use your serial number when requesting information or when ordering parts.

NOTE: The directions left, right, front and rear, as mentioned throughout this manual, are as viewed from the operator's position.

Table of Contents

1. Introduction.....	4
1.1 Attachment Identification.....	4
2. Safety	5-7
2.1 Safety Information.....	5
2.2 Importance of Safety.....	6
3. Operation	8-15
3.1 General Information.....	8
3.2 Attachment Inspection.....	9
3.3 Attachment Installation.....	10
3.4 Operating the Attachment	12
3.5 Cutter Height Adjustment.....	15
4. Maintenance	16-20
4.1 Service Schedule	16
4.2 Drive Assembly	17
4.3 Blade Assembly.....	18
4.4 Cleaning the Attachment	19
4.5 Troubleshooting	20
5. Parts.....	21-26
5.1 Parts Breakdown	21
5.2 Mount Assembly	23
5.3 Blade Carrier Assembly.....	24
5.4 Wheel Caster	25
5.5 Mini Spindle Assembly	26
6. Specifications	27-28
6.1 Attachment Specifications	27
6.2 Torque Specifications	28
7. Warranty	29

1. Introduction

1.1 Attachment Identification



2. Safety

2.1 Safety Information



SAFETY ALERT SYMBOL



This SAFETY ALERT SYMBOL identifies important safety messages on the equipment and in the owner's manual. When you see this symbol, be alert to the possibility of personal injury and carefully read the message that follows.



DANGER



The signal word **DANGER** on the machine and in the manuals indicates a hazardous situation which, if not avoided, will result in death or serious injury.



WARNING



The signal word **WARNING** on the machine and in the manuals indicates a potentially hazardous situation which, if not avoided, could result in death or serious injury.



CAUTION



The signal word **CAUTION** on the machine and in the manuals indicates a potentially hazardous situation which, if not avoided, may result in minor or moderate injury. It may also be used to alert against unsafe practices.



IMPORTANT



The signal word **IMPORTANT** identifies procedures which must be followed to avoid damage to the machine.

Safe Operation Needs a Qualified Operator



WARNING



AVOID SERIOUS INJURY OR DEATH

Operators must receive instructions before operating the machine. Untrained operators can cause serious injury or death.

For an operator to be qualified, he or she must not use drugs or alcoholic drinks which impair alertness or coordination while working. An operator who is taking prescription drugs must get medical advice to determine if he or she can safely operate a machine and the equipment.

Operator Training

- Check the rules and regulations at your location. The rules may include an employer's work safety requirements. Regulations may apply to local driving requirements or use of a Slow Moving Vehicle (SMV) emblem. Regulations may identify a hazard such as a utility line.
- The new operator must start in an area without bystanders and use all the controls until he or she can operate the machine safely under all conditions of the work area.

2. Safety

2.2 Importance of Safety

Operating Safety

- Read and follow instructions in this manual and the machine's Operators Manual before operating.
- Under no circumstances should young children be allowed to work with this equipment.
- This equipment is dangerous to persons unfamiliar with its operation.
- Check for overhead and / or underground lines before operating equipment (if applicable).
- In addition to the design and configuration of equipment, hazard control and accident prevention are dependent upon the awareness, concern, prudence and proper training of personnel involved in the operation, transport, maintenance and storage of equipment.
- Check that the attachment is securely fastened to the machine.
- Make sure all the machine controls are in the NEUTRAL before starting the machine.
- Operate the equipment only from the operator's position.
- Operate the equipment according to the Operator's Manual.
- When learning to operate the equipment, do it at a slow rate in an area clear of bystanders.
- DO NOT permit personnel to be in the work area when operating the equipment.
- The equipment must be used ONLY on approved machines.
- DO NOT modify the equipment in any way. Unauthorized modification may impair the function and / or safety and could affect the life of the equipment.
- DO NOT make any adjustments or repairs on the equipment while the machine is running.
- Keep shields and guards in place. Replace if damaged.
- DO NOT operate equipment in poor visibility conditions such as fog, darkness, or any conditions that limit clear visibility less than 300 feet (100 m) in front of and to the sides of the equipment.
- When conditions make it necessary to slow ground speed, shift to a lower gear rather than reducing engine speed. The engine will maintain rated speed and keep cutter running at optimum cutting speed.
- DO NOT operate in a work area that has not been inspected for foreign debris and obstacles.
- Remove any foreign objects and clearly mark any objects that cannot be removed.
- Wear safety glasses, gloves, hearing protection and other protective clothing when required.

Machine Requirements and Capabilities

- The machine's operator's cab should be equipped with a thermoplastic polycarbonate or similar material front window, and similar protection on the sides of the operator's cab before operating the equipment.
- Keep bystanders clear of moving parts and the work area. Keep children away.
- Do Not exceed 4000 psi (275 bar) operating pressure.
- Use caution on slopes and near banks and ditches to prevent overturn

2. Safety

Fire Prevention Safety

- Flammable debris (leaves, grass, etc.) must be removed regularly. If flammable debris is allowed to accumulate, it can cause a fire hazard. Clean often to avoid this accumulation.
- The equipment's hydraulic motor compartment must be inspected every day and cleaned if necessary to prevent fire hazards and overheating.
- All fuels, most lubricants, and some coolant mixtures are flammable. Flammable fluids that are leaking or spilled onto hot surfaces or onto electrical components can cause a fire.

Transporting Safety

- Comply with state and local laws governing highway safety and movement of machinery on public roads.
- Check local laws for all highway lighting and marking requirements.
- Always yield to oncoming traffic and move to the side of the road so any following traffic may pass.
- Never allow riders on either machine or equipment.
- If transporting the brush cutter on a truck or trailer, make sure the brush cutter is properly secured to the transport vehicle.

Hydraulic System

- Check hydraulic tubes, hoses, and fittings for damage and leakage. Never use open flame or bare skin to check for leaks. Hydraulic tubes and hoses must be properly routed and have adequate support and secure clamps. Tighten or replace any parts that show leakage.
- Always clean fluid spills. Do not use gasoline or diesel fuel for cleaning parts. Use commercial nonflammable solvents.

3. Operation

3.1 General Information

Pre-Operation Inspection

Before operating the Dual Spindle Brush Cutter for the first time and each time thereafter, use the following list as a guideline during equipment inspection.



WARNING



AVOID SERIOUS INJURY OR DEATH

- Disengage machine's auxiliary hydraulics, engage the machine's parking brake, stop the engine and make sure all rotating components are completely stopped before connecting, disconnecting, adjusting or cleaning equipment.
- Always keep shields and all guards in place when using the equipment.
- Disengage machine's auxiliary hydraulics for road travel.
- Keep hands, feet and clothing away from rotating parts.

Fully clean the attachment. See "Cleaning the Attachment" on page 19.

- Lubricate the attachment per the schedule outline in the Maintenance Section. See "Service Schedule" on page 16.
- Check the brush cutter mounting plate for damage. Check for loose or missing parts. Repair as needed before operation.
- Check all welds on the attachment for wear and damage each time the attachment is removed from the machine.
- Check for damaged or missing safety decals. Replace if necessary.
- Inspect the safety chain for damage. Not all machines will attach the same; see Figure 1 for an example of how a chain might attach.



Figure 1

- Inspect the machine's mounting frame. (See the machine's Operator's Manual for inspecting the mounting frame). Replace any parts that are damaged, bent, or missing. Keep all fasteners tight. Look for cracked welds.



WARNING



Leaking fluids under pressure can enter the skin and cause serious injury or death. Immediate medical attention is required.

Wear goggles. Use cardboard to check for leaks.

- Check condition of all hydraulic components for leaks. Repair as required.

NOTE: Do not operate with hydraulic leaks

- Verify that the brush cutter is properly connected to the machine.

3. Operation

3.2 Attachment Inspection

Daily Inspection

NOTE: Inspect the attachment by performing a walk around daily before and after use. Use the following inspection checklist as a guideline.

Check the following items every 10 hours of operation:

- Verify that the brush cutter is properly connected to the machine.
- Check that all shields and guards are in place.
- Check hydraulic lines, connections and fittings for hydraulic oil leaks. Repair or replace damaged parts if necessary.
- Check the brush cutter mounting hardware for wear or damage. Inspect the pins and mount (on the attachment) for wear or damage. Repair or replace damaged parts if necessary.

Weekly Inspection

Check the following items every 40 hours of operation:

- Check blade bolts for correct torque 500 ft/ lb. (678.0 N•m).
- Check all bolts for tightness.
- 3/8" bolts to 50 ft/lb (67.5 N•m) torque. 1/2" bolts to 100 ft/lb (135 N•m) torque.
- Inspect the deck for cracks, bends, or damage.
- Inspect discharge chains and replace any missing or broken chains.

Monthly Inspection

- Inspect the blades for cracks, bends, or excessive wear.
- Check skid plates for wear.
- Check that all bolts are tight.
- Check blades and mounting plate for cracks or damage. Replace if necessary.
- Check blade mounting hardware for correct torque 500 ft/ lb. (678.0 N•m). Check mounting plate hardware.
- Check chains, deck, shields and guards. Repair if damaged or replace if necessary.
- Check for damaged or missing decals. Replace if necessary.
- Check for damaged or leaking hydraulic hoses or fittings. Replace if necessary.
- Clean all debris, leaves, grass and flammable material from deck area and under covers.
- Lubricate as required



WARNING



AVOID SERIOUS INJURY OR DEATH

Before servicing the attachment:

- **Always park on a flat level surface.**
- **Lower lift arms and place attachment flat on the ground.**
- **Place all controls in NEUTRAL.**
- **Engage the park brake.**
- **Wait for all moving parts to stop.**
- **Stop the engine and remove the key.**

SEE MACHINE'S OPERATOR'S MANUAL FOR ADDITIONAL INFORMATION.

3. Operation

3.3 Attachment Installation

Connecting Attachment To The Machine

IMPORTANT



See the machine's Operator's Manual for detailed information on operating the loader.

Entering The Operator's Position

Use the attachment safety treads, handles and steps (on the machine) to enter the operator's position.

When in the operator's position, lower safety seat bar, start the engine and release the parking brake.

Leaving The Operator's Position

WARNING

AVOID SERIOUS INJURY OR DEATH

- **Always park on a flat level surface.**
- **Lower lift arms and place attachment flat on the ground.**
- **Place all controls in NEUTRAL.**
- **Engage the park brake.**
- **Stop the engine and remove the key.**
- **Wait for all moving parts to stop.**

SEE MACHINE'S OPERATOR'S MANUAL FOR ADDITIONAL INFORMATION.

Park the machine / attachment on a flat level surface.

Place all controls in neutral, engage the park brake, stop the engine and wait for all moving parts to stop. Leave the operator's position.

WARNING



CRUSH HAZARD

- **Before moving the machine, look in all directions and make sure no bystanders, especially small children are in the work area. Do not allow anyone between the machine and attachment when approaching the attachment for connecting.**
- **Keep fingers and hands out of pinch points when connecting and disconnecting the attachment.**

Before connecting to the attachment, inspect the machine's mounting plate. (See the machine's Operator's Manual for inspecting the mounting frame).

Enter the operator's position. See "Entering The Operator's Position" on page 10.

Drive the machine slowly forward, until the top edge of the machine's mounting plate is under the top flange of the attachment mounting frame.

Slowly tilt the machine's mounting plate back until the attachment mounting frame fully contacts the front of the machine's mounting plate.

Leave the operator's position. See "Leaving The Operator's Position" on page 10.

3. Operation

Connecting Attachment to the Machine Cont'd

Slowly tilt the machine's mounting plate back until the attachment mounting frame fully contacts the front of the machine's mounting plate.

Leave the Operator's position. See "Leaving the Operator's Position" on page 10.



WARNING



AVOID SERIOUS INJURY OR DEATH

The locking pins / wedges must extend through the holes in the attachment mounting frame. Failure to secure locking pins / wedges can allow attachment to come off. SEE MACHINE'S OPERATOR'S MANUAL FOR ADDITIONAL INFORMATION.

Engage attachment locking levers / wedges (See the machine's Operator's Manual for detailed information).

Connecting Hydraulic Hoses



IMPORTANT



- Thoroughly clean the quick couplers before making connections. Dirt can quickly damage the hydraulic system.

Remove dirt or debris from the male and female couplers. Visually inspect the couplers for corroding, cracking, damage, or excessive wear. Replace as needed.

Connect the attachment hydraulic hoses to the machine. Pull on each hose to verify full connection is made.

Disconnecting Hydraulic Hoses



WARNING



AVOID SERIOUS INJURY OR DEATH
Hydraulic fluid, tubes, fittings, and quick couplers can get hot during operation. Be careful when connecting and disconnecting hydraulic hoses.

Relieve auxiliary hydraulic pressure. (See the machine's Operator's Manual for correct procedure.)

Disconnect attachment hydraulic hoses from the machine.

Disconnecting Attachment From the Machine

Relieve auxiliary hydraulic pressure. (See the machine's Operator's Manual for correct procedure.)

Park the machine and attachment on a flat level surface. Lower the attachment flat on the ground.

Leave the operator's position. See "Leaving The Operator's Position" on page 10.

Disconnect attachment hydraulic hoses from the machine.

Disengage locking pins / wedges. (See the machine's Operator's Manual for correct procedure.)

Enter the operator's position. See "Entering The Operator's Position" on page 10.

Slowly tilt the machine's mounting plate forward until the attachment mounting frame is free from the machine's mounting plate.

Drive the machine slowly backward, away from the attachment.

3. Operation

3.4 Operating the Attachment

Machine Requirements



DANGER



FLYING DEBRIS OR OBJECTS WILL CAUSE SERIOUS INJURY OR DEATH

To protect the operator from any flying debris or objects, it is important that the machine's operator's cab should be equipped with a thermoplastic polycarbonate or similar material front window, and similar protection on the sides of the operator's cab before operating the Severe Duty Brush Cutter.



WARNING



THROWN OBJECTS OR ROTATING BLADES CAN CAUSE SERIOUS INJURY OR DEATH

- Clear work area of all debris, such as rope, wire, cable or other materials that can wrap around blade carrier and blades, causing entanglement and attachment damage.
- **DO NOT** operate brush cutter in vicinity of bystanders, animals, or damageable property. Objects can be thrown more than several hundred feet.
- Keep all chains and shields installed. Repair or replace if damaged or missing.
- Check blade carrier, blades and mounting hardware. Replace if damaged. Never weld or modify.

Dual Spindle Brush Cutter			
Model	Motor Size	Weight (lbs)	Flow (GPM)
103920	80 cc	1,865	15 - 22
103930	125 cc	1,865	23 - 30

3. Operation



DANGER



ROTATING BLADES WILL CAUSE SERIOUS INJURY OR DEATH

- Never put hands, feet or objects into or under brush cutter when engine is running.
- Keep bystanders away.
- No riders.
- Stop engine before leaving the machine to service.



IMPORTANT



DO NOT operate brush cutter when excessive vibration is present. Serious damage can result. Check blade carrier, blades and mounting hardware. Replace if damaged.

NOTE: The ground conditions and the type of brush being cut will determine the best cutting procedure and ground speed. The Severe Duty Brush Cutter is designed to cut short or tall grass, brush and small trees up to 4 in. (102 mm) in diameter.



WARNING



AVOID SERIOUS INJURY OR DEATH

- Never operate the Brush Cutter with back of the deck more than 24 in. (610 mm) off the ground.
- Never operate the Brush Cutter with any guards removed, including the motor cover.



WARNING



Never allow riders on the brush cutter.

3. Operation

Clearing Work Area

! IMPORTANT !

- DO NOT operate in a work area that has not been cleared of foreign debris and obstacles.
- Rocks, metal, construction debris and other objects can damage the blade carrier and blades.
- Wire and similar debris can damage drive seals, the blade carrier, and blades.
- Clearly mark any objects that cannot be removed.



Initial Setup

Install the dual spindle brush cutter onto the machine.

Move to the operator's position, lower seat bar, start the engine and release the parking brake.

Engage the machine's front auxiliary hydraulics.

Using the machine's auxiliary hydraulic controls, start blade rotation.

! IMPORTANT !

To minimize larger cut material discharging to the rear, always keep the machine between material being cut (work area) and buildings, occupied areas or roadways.

! CAUTION !

DO NOT exceed 4000 PSI operating pressure. Serious damage can result.

Cutting Procedures

Brush Cutting

With the blades rotating, tilt the machine's mounting frame backward, raising the front of the brush cutter to roughly a 45° angle. Slowly drive forward into the brush. Slowly lower the brush cutter and start cutting.

Grass Cutting

With the blades rotating, tilt the machine's mounting frame until the brush cutter deck is parallel to the ground. Lower the brush cutter deck to the ground or desired cutting height. Drive forward and start cutting.

3. Operation

3.5 Cutter Height Adjustment

Leveling the deck:

1. Park the host machine on level ground, with the attachment raised slightly off the ground, and the hydraulics safely blocked.
2. Loosen the teardrop-shaped tabs (Item 1) [Figure 2] away from the center of the turnbuckle.
3. Using a screwdriver or similar tool inserted into the center of the turnbuckle (Item 2) [Figure 2], adjust the length of each turnbuckle until the angle of the deck is level with the machine.
4. Turn the teardrop shaped tabs backwards against the middle section of each turnbuckle to tighten them in place.

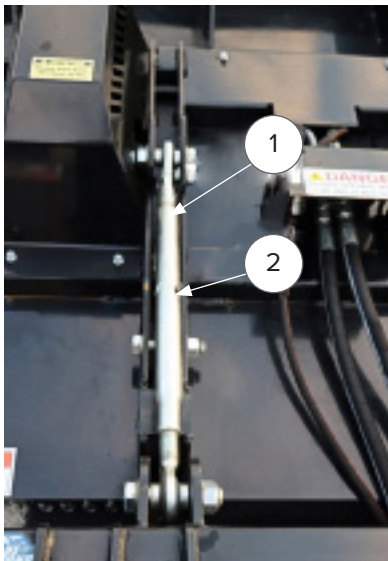

Figure 2

Adjusting the cutting height

1. Park the host machine on level ground, with the attachment raised slightly off the ground, and the hydraulics safely blocked.
2. Remove the bolt and bushing (Item 1) [Figure 3] from the top of the wheel yoke, remove any height adjustment spacers (Item 2) [Figure 3], and remove the wheel and yoke from the rest of the deck.



CAUTION



Caster Wheel is heavy and unwieldy. Use appropriate lifting device to avoid injury.

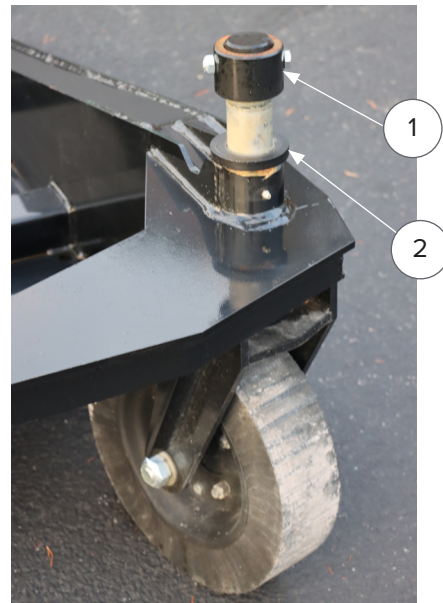

Figure 3

3. Increase or decrease the number of height adjustment spacers on the wheel yoke as needed.
4. Reassemble in reverse order.

4. Maintenance

4.1 Service Schedule

DESCRIPTION	SERVICE PROCEDURES					
	Check	Clean	Lube	Change	Adjust	Drain
Daily Maintenance (or every 8 hours)						
Hydraulic Fittings	•					
Hydraulic Hoses	•					
Hydraulic Motor	•	•				
Blades (wear, damage, and loosening)	•					
Blade Carrier	•					
All Hardware	•					
Deck	•	•				
Chain Guard	•					
Wheel Grease Fittings			•			
Weekly Maintenance (or every 40 hours)						
Blade Bolt Torque - 500 ft/lb (678.0 N•m)	•					
All Hardware	•					
Deck (cracks, bends, or damage)	•					
Chain Guard (replace missing/ broken chains)	•					
Monthly Maintenance						
Blades (cracks, bends, or excessive wear)	•					
Skid plates	•					
All Hardware	•					
250 Hour Maintenance						
Drive Assembly (5-10 pumps)				•		



4. Maintenance

4.2 Drive Assembly

Lubrication



Fluid such as hydraulic fluid, coolants, grease, et. must be disposed of in an environmentally safe manner. Some regulations require that certain spills and leaks on the ground must be cleaned in a specific manner. See local, state, and federal regulations for the correct disposal.



Figure 5

Apply 5-10 pumps of grease to the grease zerk on the wheel assemblies (Item 1) [Figure 5]

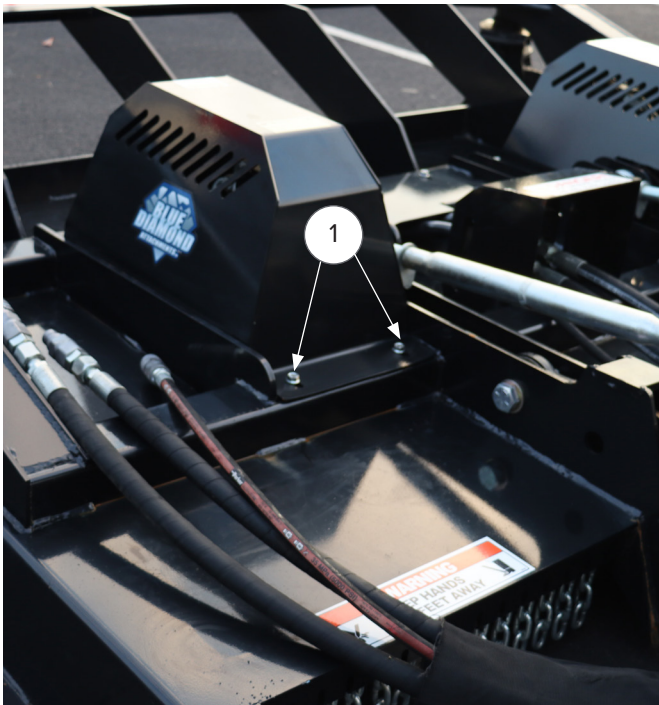

Figure 4

Loosen the bolts (Item 1) [Figure 4] and remove cover to access the grease zerk (Item 2) [Figure 4].

Apply 5-10 pumps of grease to the grease zerk.

Align cover, reinstall, and tighten bolts.

4. Maintenance

4.3 Blade Assembly

Blade Tightening / Replacement



DANGER



AVOID INJURY OR DEATH

Before servicing the Brush Cutter:

- Lower the lift arms and place the brush cutter on flat, level surface.
- Engage parking brake, stop engine, and exit the machine.
- Disconnect attachment hydraulic hoses.

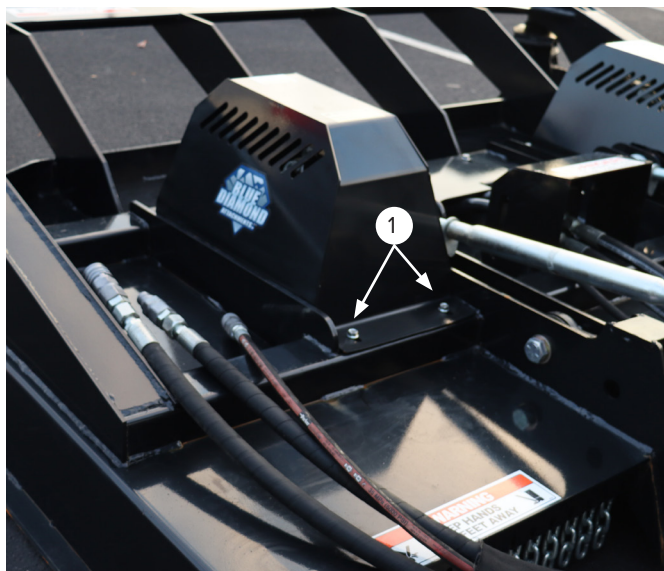

Figure 6

Remove the four bolts (Item 1) [Figure 6] and motor cover to access the blade nut.

Tightening Blade Bolts

Tighten bolts and nuts to 500 foot pounds of torque.

Turn blade carrier by hand to align the next blade nut with the access hole.

Repeat procedure until all blade nuts and bolts have been tightened.

Reinstall cover

Blade Removal

Remove the nut and bolt from the blade. Remove blade.

Turn blade carrier by hand to align the next blade nut with the access hole.

Repeat procedure until all blade nuts and bolts have been removed.

NOTE: Blue Diamond® recommends replacing the bolt and nut every time the blades are changed.

Blade Installation

Align blade with the hole in the blade carrier. Push the bolt up through the blade into the blade carrier.

NOTE: Verify that blade bolt is fully seated.

Thread nut on blade bolt. Tighten nut to 500 foot pounds of torque.

Turn blade carrier to align remaining blade mounting holes.

Repeat procedure until all blades have been installed.

Reinstall cover.

4. Maintenance

4.4 Cleaning the Attachment



DANGER



AVOID SERIOUS INJURY OR DEATH

Before servicing the Brush Cutter:

- Disconnect attachment hydraulic hoses.
- Raise the lift arms and tilt brush cutter fully forward (down) until the front of the brush cutter contacts the ground.
- Engage parking brake, stop engine, and exit the machine.



Figure 7

Park the machine and attachment on a flat level surface. Lower the attachment flat on the ground.

Leave the operator's position. See "Leaving the Operator's Position" on page 10.

Disconnect attachment hydraulic hoses from the machine.

Enter the operator's position. See "Entering the Operator's Position" on page 10.

Start the engine, slowly raise the machine's lift arms, while tilting the brush cutter forward (down) until the front of the brush cutter contacts the ground [Figure 7].

Stop the engine, engage parking brake, and leave the operator's position. See "Leaving the Operator's Position" on page 10.

Use water or air pressure to clean debris from under the brush cutter deck.

Be careful when removing any obstructions that are wrapped around blades and blade carrier.

4. Maintenance

4.5 Troubleshooting

PROBLEM	CAUSE	SOLUTION
Brush Cutter Vibrating	Broken or damaged blades	Check blades and replace as needed.
	Debris under deck or on blade carrier	Remove all debris and verify all parts rotate freely.
	Loose or missing blade bolts	Replace missing bolts and tighten all blade bolts.
Low pressure at Startup/ Blades Turning too Slow	Hydraulic couplers are reversed.	Reverse male and female. Check for correct pressure.
	Faulty Relief valve on brush cutter or machine.	Contact your dealer or Blue Diamond® Attachments Service Department.
	Hi-Flow hydraulics not engaged (if required)	Engage Hi-Flow hydraulics.
Hydraulic Pressure, but Blades not Rotating	Debris under deck or on blade carrier.	Remove all debris and verify all parts rotate freely.
	Against an obstacle preventing the blade carrier from rotating.	Adjust brush cutter until blades rotate freely.
	Drive is damaged or seized.	Check blades and blade carrier. Verify that blades and blade carrier rotate freely. Replace damaged or seized drive.
	Damaged motor shaft or seized motor.	Contact your dealer or Blue Diamond® Attachments Service Department.
Poor Cutting	Travel speed too slow.	Increase travel speed during operation.
	Broken or dull blades.	Replace blades as needed.
	Hi-Flow hydraulics not engaged (if required)	Engage Hi-Flow hydraulics.

5. Parts

ITEM	PART NUMBER	DESCRIPTION	QTY
1	202900	Deck Weldment	1
2	202902	Motor Cover - Left	1
3	202904	Motor Cover - Right	1
4	202906	Relief Valve Cover	1
5	202908	Hose Cover	1
6	202915	Relief Valve Block Assembly	1
NS	299425	Relief Block Bolt	2
NS	208550	Relief Block Nut	2
7	299342	3/8 x 1" Flanged Bolt	16
8	202920	Chain Retainer Rod	2
9	203045	4-link chain	32
10	See page 24	Blade Carrier Assembly	2
11	See page 25	Wheel Caster Assembly	2
12	See page 23	Mount Assembly	1
13	See page 26	Direct Drive	
14	203760	80cc Motor	2
	203765	125cc Motor	2
15	299433	Motor Bolt	8
16	299830	Motor Washer	8
17	299466	Drive Bolt	12
18	216571	Drive Nut	12
NS	202901	Hose Set	1

5. Parts

5.2 Mount Assembly

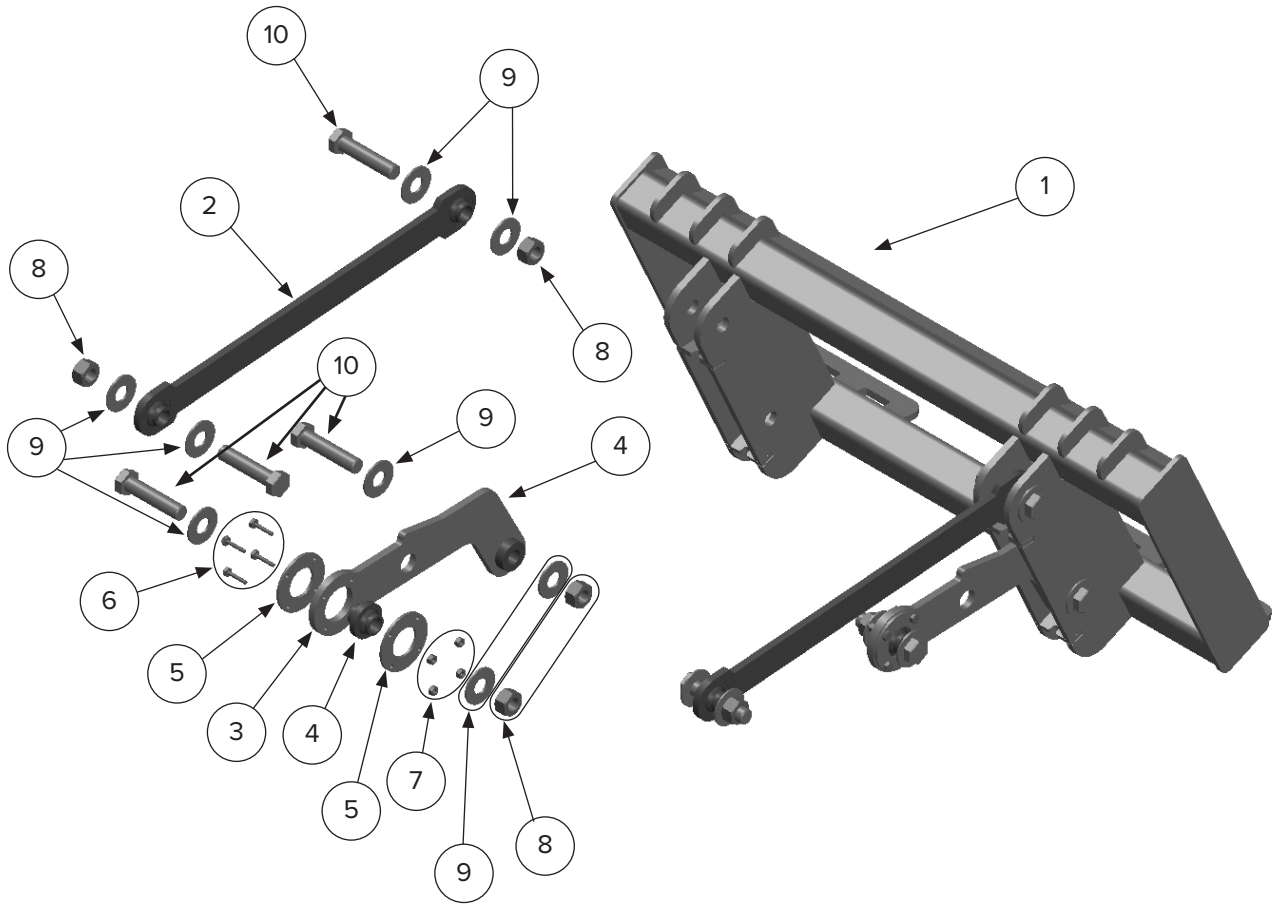

ITEM	PART NUMBER	DESCRIPTION	QTY
1	202924	Frame Weldment	1
2	202926	Top Link Assembly	2
3	202928	Bottom Link Assembly	2
4	202940	Category 2 Link Ball End	2
5	202938	Link Ball Retainer Plate	4
6	299418	1/4 x 1.5" Bolt	8
7	299653	1/4" Nut	8
NS	216405	1/4" Flat Washer	8
8	299659	1" Nut	8
9	299750	1" Washer	16
10	299477	1 x 4/5" Bolt	8

5. Parts

5.3 Blade Carrier Assembly

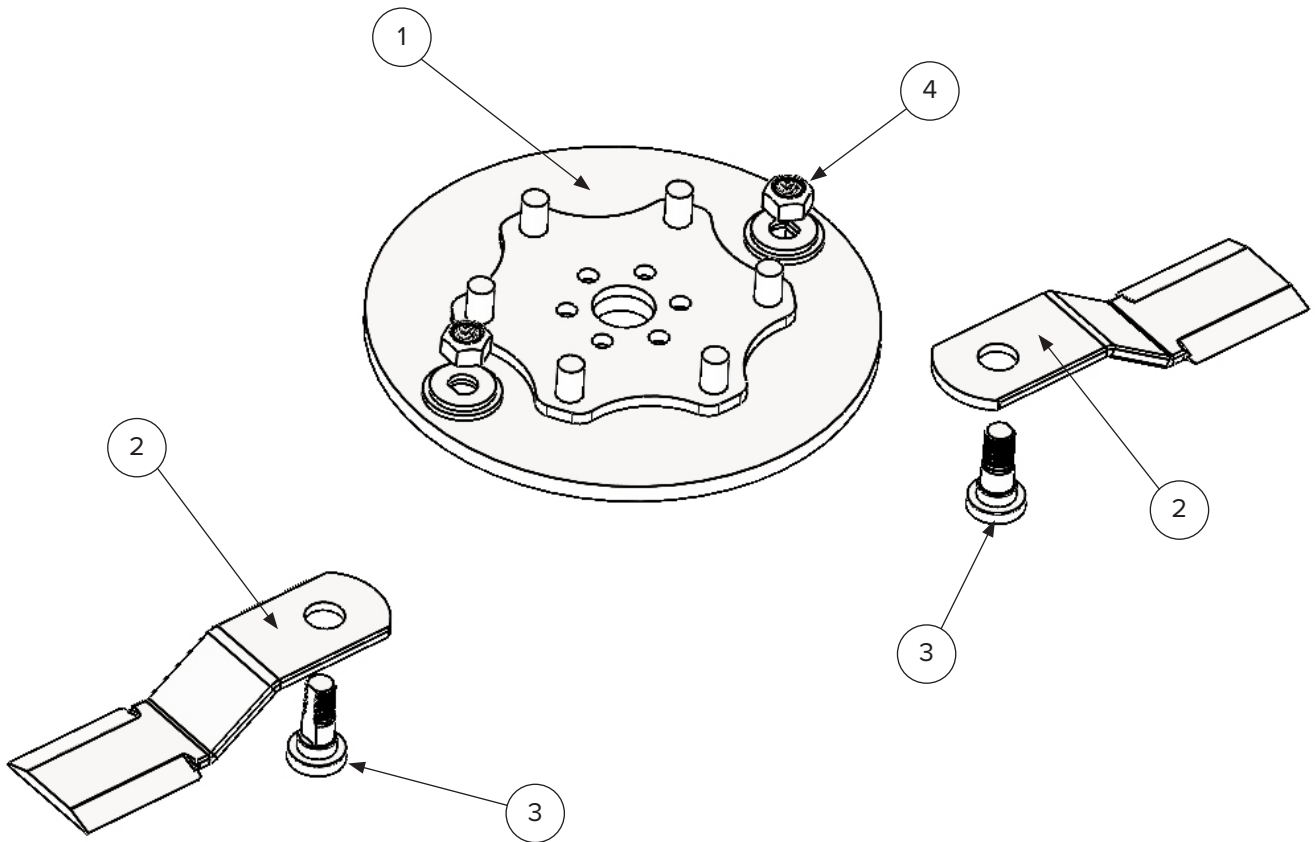

ITEM	PART NUMBER	DESCRIPTION	QTY
1	202960	Blade Carrier with Wire Guard	1
2	203028	Blade	2
3	203035	Blade Bolt	2
4	203030	Blade Nut	2

5. Parts

5.4 Wheel Caster Assembly

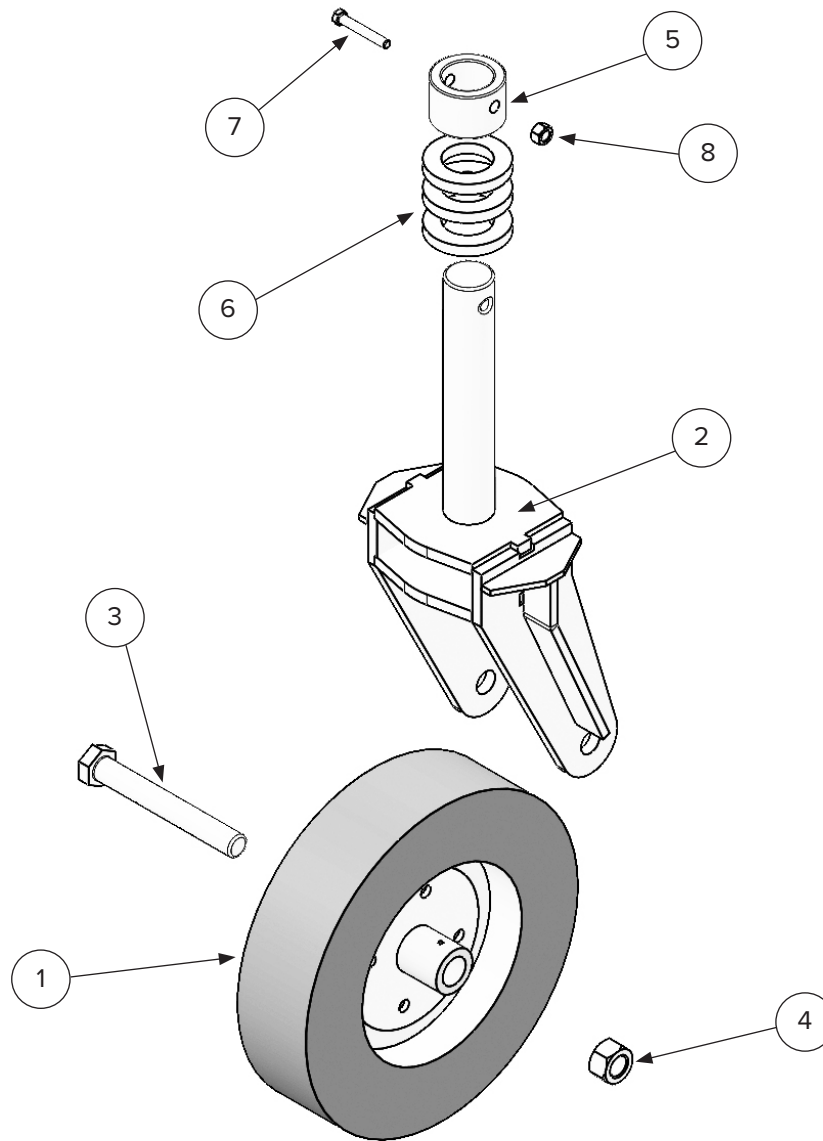

ITEM	PART NUMBER	DESCRIPTION	QTY
1	202950	Solid Tire with Hub	1
2	202952	Wheel Fork	1
3	299475	1 x 7.5" Bolt	1
4	299659	1" Nut	1
5	202954	Tire Bushing	1
6	202956	Height Adjustment Rings	3
7	299437	1/2 x 4" Bolt	1
8	299655	1/2" Nut	1

5. Parts

5.5 Mini Spindle Assembly

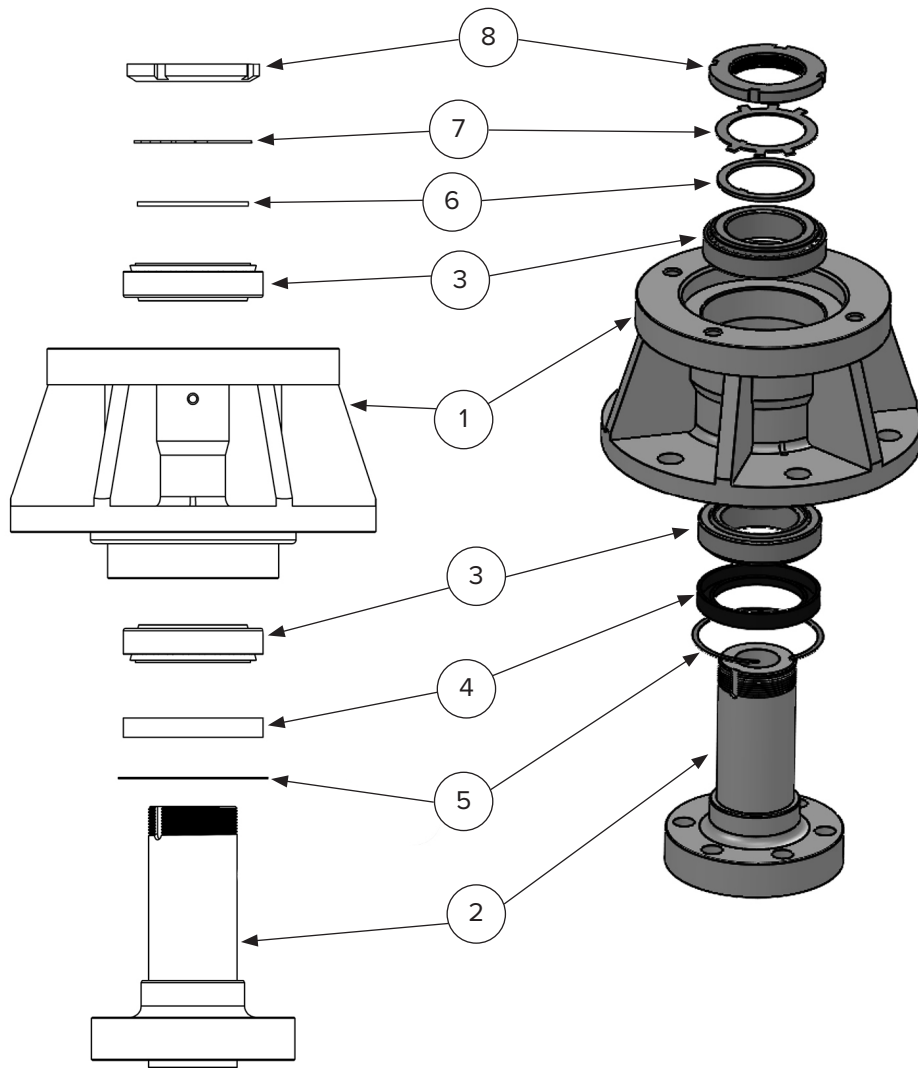

ITEM	PART NUMBER	DESCRIPTION	QTY
1-8	203629	Complete Assembly	1
1	203630	Housing	1
2	203632	Spindle	1
3	203635	Tapered Bearing	2
4	203638	Seal	1
5	203639	Retention Ring	1
6	203640	Washer	1
7	203642	Lock Washer	1
8	203645	Nut	1
NS	203109	Grease Bellows	1

6. Specifications

6.1 Attachment Specifications

DESCRIPTION	DUAL SPINDLE BRUSH CUTTER	
	W/ 80 CC MOTOR	W/ 125 CC MOTOR
Overall Height	30 in. (762 mm)	
Overall Length	84 in. (2157 mm)	
Overall Width	90 in. (2286 mm)	
Cutting Height (min/max)	2.5 in. (63 mm) – 6 in. (152 mm)	
Cutting Width	84 in. (2134 mm)	
Weight	1,865 lbs. (846 kg)	
Blade Type	Double Edge, drop down, 6-1/4" wide, heat treated	
Number of Blades	4 double sided	
Drive System	Direct Drive	
Minimum Hydraulic Flow	15 GPM (57 L/min)	23 GPM (87 L/min)
Maximum Hydraulic Flow	22 GPM (83 L/min)	30 GPM (114 L/min)
Maximum Pressure	4000 PSI (275 bar)	
Drive Lubricant (or equivalent)	Shell Gadus Red Lithium S5 V100 2 Grease	

6. Specifications

6.2 Torque Specifications

Standard Hardware and Lock Nuts

BOLT TYPE	SAE GRADE 5		SAE GRADE 8		LOCK NUTS			
	Nominal Size	Plated or Unplated Silver	Plated W/ ZnCr Gold	Plated or Unplated Silver	Plated W/ ZnCr Gold	Plated or Unplated Silver	Plated W/ ZnCr Gold	W/ Grade 5 Bolt
1/4	55 in / lb (6.2 N•m)	72 in / lb (8.1 N•m)	86 in / lb (9.7 N•m)	112 in / lb (12.6 N•m)	121 in / lb (13.6 N•m)	157 in / lb (17.7 N•m)	61 in / lb (6.9 N•m)	86 in / lb (9.8 N•m)
5/16	115 in / lb (13 N•m)	149 in / lb (17 N•m)	178 in / lb (20 N•m)	229 in / lb (26 N•m)	250 in / lb (28 N•m)	325 in / lb (37 N•m)	125 in / lb (14 N•m)	176 in / lb (20 N•m)
3/8	17 ft / lb (23 N•m)	22 ft / lb (30 N•m)	26 ft / lb (35 N•m)	34 ft / lb (46 N•m)	37 ft / lb (50 N•m)	48 ft / lb (65 N•m)	19 ft / lb (26 N•m)	26 ft / lb (35 N•m)
7/16	27 ft / lb (37 N•m)	35 ft / lb (47 N•m)	42 ft / lb (57 N•m)	54 ft / lb (73 N•m)	59 ft / lb (80 N•m)	77 ft / lb (104 N•m)	30 ft / lb (41 N•m)	42 ft / lb (57 N•m)
1/2	42 ft / lb (57 N•m)	54 ft / lb (73 N•m)	64 ft / lb (87 N•m)	83 ft / lb (113 N•m)	91 ft / lb (123 N•m)	117 ft / lb (159 N•m)	45 ft / lb (61 N•m)	64 ft / lb (88 N•m)
9/16	60 ft / lb (81 N•m)	77 ft / lb (104 N•m)	92 ft / lb (125 N•m)	120 ft / lb (163 N•m)	130 ft / lb (176 N•m)	169 ft / lb (229 N•m)	65 ft / lb (88 N•m)	92 ft / lb (125 N•m)
5/8	83 ft / lb (112 N•m)	107 ft / lb (145 N•m)	128 ft / lb (174 N•m)	165 ft / lb (224 N•m)	180 ft / lb (244 N•m)	233 ft / lb (316 N•m)	90 ft / lb (122 N•m)	127 ft / lb (172 N•m)
3/4	146 ft / lb (198 N•m)	189 ft / lb (256 N•m)	226 ft / lb (306 N•m)	293 ft / lb (397 N•m)	319 ft / lb (432 N•m)	413 ft / lb (560 N•m)	160 ft / lb (217 N•m)	226 ft / lb (306 N•m)
7/8	142 ft / lb (193 N•m)	183 ft / lb (248 N•m)	365 ft / lb (495 N•m)	473 ft / lb (641 N•m)	515 ft / lb (698 N•m)	667 ft / lb (904 N•m)	258 ft / lb (350 N•m)	364 ft / lb (494 N•m)
1	213 ft / lb (289 N•m)	275 ft / lb (373 N•m)	547 ft / lb (742 N•m)	708 ft / lb (960 N•m)	773 ft / lb (1048 N•m)	1000 ft / lb (1356 N•m)	386 ft / lb (523 N•m)	545 ft / lb (739 N•m)



Warranty

MANUFACTURER'S LIMITED WARRANTY

BLUE DIAMOND® ATTACHMENTS, a manufacturer of quality attachments, warrants new BLUE DIAMOND® ATTACHMENTS products and/or attachments at the time of delivery to the original purchaser, to be free from defects in material and workmanship when properly set up and operated in accordance with the recommendations set forth by BLUE DIAMOND® ATTACHMENTS, LLC.

BLUE DIAMOND® ATTACHMENTS liability for any defect with respect to accepted goods shall be limited to repairing the goods at a BLUE DIAMOND® ATTACHMENTS designated location or at an authorized dealer location, or replacing them, as BLUE DIAMOND® ATTACHMENTS shall elect. The above shall be in accordance with BLUE DIAMOND® ATTACHMENTS warranty adjustment policies. BLUE DIAMOND® ATTACHMENTS obligation shall terminate twelve (12) months for the Dual Spindle Brush Cutter after the delivery of the goods to original purchaser.

This warranty shall not apply to any machine or attachment which shall have been repaired or altered outside the BLUE DIAMOND® ATTACHMENTS factory or authorized BLUE DIAMOND® ATTACHMENTS dealership or in any way so as in BLUE DIAMOND® ATTACHMENTS judgment, to affect its stability or reliability, nor which has been subject to misuse, negligence or accident beyond the company recommended machine rated capacity.

WARRANTY CLAIM

To submit a warranty claim, a claim must be filed with BLUE DIAMOND® ATTACHMENTS before work is performed. The BLUE DIAMOND® PRODUCT SUPPORT TEAM will advise repairs and applicable parts exchanges. Tampering with the failed part may void the warranty. This warranty does not include freight or delivery charges incurred when returning machinery for servicing. Dealer mileage, service calls, and pickup/delivery charges are the customers' responsibility.

EXCLUSIONS OF WARRANTY

Except as otherwise expressly stated herein, BLUE DIAMOND® ATTACHMENTS makes no representation or warranty of any kind, expressed or implied, AND MAKES NO WARRANTY OF MERCHANTABILITY IN RESPECT TO ITS MACHINERY AND/OR ATTACHMENTS ARE FIT FOR ANY PARTICULAR PURPOSE. BLUE DIAMOND® ATTACHMENTS shall not be liable for incidental or consequential damages for any breach or warranty, including but not limited to inconvenience, rental of replacement equipment, loss of profits or other commercial loss. Upon purchase, the buyer assumes all liability for all personal injury and property resulting from the handling, possession, or use of the goods by the buyer.

No agent, employee, or representative of BLUE DIAMOND® ATTACHMENTS has any authority to bind BLUE DIAMOND® ATTACHMENTS to any affirmation, representation, or warranty concerning its machinery and/or attachments except as specifically set forth herein.

This warranty policy supersedes any previous documents.

NOTE: Blue Diamond® Attachments is a trademark of BLUE DIAMOND® ATTACHMENTS



QUALITY | DEPENDABILITY | INTEGRITY

Blue Diamond® Attachments
4512 Anderson Road, Knoxville, TN 37918
888-376-7027