

# Low Flow Cold Planer

Operation and Maintenance Manual

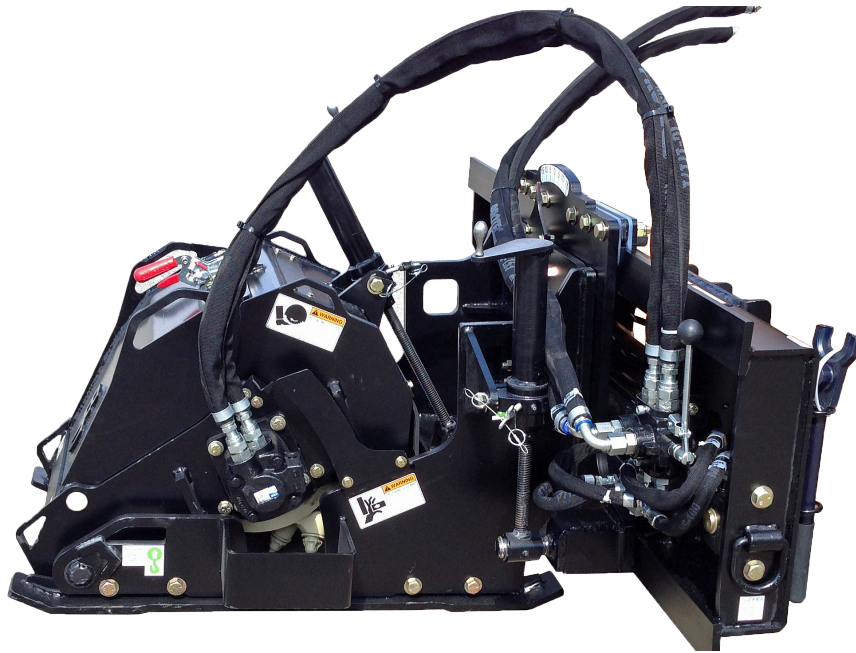

Register your  
**WARRANTY**  
within 30 days  
of purchase



888-376-7027 | [BlueDiamondAttachments.com](http://BlueDiamondAttachments.com)



BD-092

# Introduction: Owner Information

Thank you for your decision to purchase a Blue Diamond® Low Flow Cold Planer. To ensure maximum performance of your equipment, it is mandatory that you thoroughly study the Operator's manual and follow the recommendations. Proper operation and maintenance are essential to maximize equipment life and prevent personal injury.

Operate and maintain this equipment in a safe manner and in accordance with all applicable local, state, and federal codes, regulations and /or laws. Follow all on-product labeling and instructions.

Make sure that all personnel have read this Operator's Manual and thoroughly understand safe and correct operating, installation and maintenance procedures.

Blue Diamond is continually working to improve its products. Blue Diamond reserves the right to make any improvements or changes as deemed practical and possible without incurring any responsibility or obligation to make any changes or additions to equipment sold previously.

Although great care has been taken to ensure the accuracy of this publication, Blue Diamond makes no warranty or guarantee of any kind, written or expressed, implied or otherwise with regard to the information contained within this manual. Blue Diamond assumes no responsibility for any errors that may appear in this manual and shall not be liable under any circumstances for incidental, consequential or punitive damages in connection with, or arising from the use of this manual.

Keep this manual available for frequent reference. All new operators or owners must review the manual before using the equipment and annually thereafter. Contact your Blue Diamond Attachments Dealer for assistance, information, or additional copies of the manual. Contact [www.bluediamondattachments.com](http://www.bluediamondattachments.com) or call 888-376-7027 for a complete list of dealers in your area.

## Serial Number Location:

Please record attachment information in the space provided for future reference.



Model Number: \_\_\_\_\_

Serial Number: \_\_\_\_\_

Dealer Name: \_\_\_\_\_

Dealer Number: \_\_\_\_\_

Date of Purchase: \_\_\_\_\_

The Serial Number is located on the right side of the attachment, on the rear of the mount plate.

Always use your serial number when requesting information or when ordering parts.

**NOTE:** The directions left, right, front and rear, as mentioned throughout this manual, are as viewed from the operator's position.

# Table of Contents

---

1. About this Manual .....	4
1.1 Hazard Notices used in this manual .....	4
1.2 Terminology .....	4
2. Safety .....	5-7
2.1 Safety Decals .....	5
2.2 Safety Precautions.....	5
2.3 Mandatory Shutdown Procedure .....	6
2.4 Safe Operating Procedure.....	7
3. Setup .....	8
3.1 Safety Decals .....	8
3.2 Hydraulic Couplers.....	8
3.3 Hoses/Fittings.....	8
3.4 Drum Assembly .....	8
4. Operation .....	9
4.1 Attaching the Prime Mover .....	9
5. Maintenance.....	10-12
5.1 Pick/Holder Replacement .....	10
5.2 Lubrication.....	11
5.3 Drum Removal .....	11
5.4 Drum Motor Removal.....	12
6. Diagram & Parts.....	13-26
6.1 Chassis Parts.....	13-14
6.2 Depth Skid Parts .....	15-16
6.3 Attach Group.....	17-18
6.4 Drivetrain and Drum Group .....	19-20
6.5 Hydraulic Group.....	21-22
6.6 Decal Group.....	23-24
6.7 Hydraulic Schematics.....	25
7. Specifications.....	12
7.1 Specification Table .....	26
8. Warranty .....	27

# 1. About this Manual

---

## About this Manual

This manual contains information about the usage and maintenance required for the equipment. This document must be available for review by the operator before using the attachment to ensure proper safety, maintenance, and usage.

## 1.1 Hazard Notices Used in this Manual

The following hazard notices are used in this document:

**NOTE:** Notes are used to indicate important information. This information may be repeated in other areas of the manual.

## 1.2 Terminology

**Prime Mover:** The Cold Planer can be attached to many different pieces of equipment; therefore, the term “prime mover” will be used. A prime mover is any equipment, tractor, or skid steer providing power to the attachment.



**CAUTION**



The signal word **CAUTION** on the machine and in the manuals indicates a potentially hazardous situation which, if not avoided, may result in minor or moderate injury. It may also be used to alert against unsafe practices.



**WARNING**



The signal word **WARNING** on the machine and in the manuals indicates a potentially hazardous situation which, if not avoided, could result in death or serious injury.



**DANGER**



The signal word **DANGER** on the machine and in the manuals indicates a hazardous situation which, if not avoided, will result in death or serious injury.

## 2. Safety

### 2.1 Safety Decals

The safety decals existing on the attachment should be clearly readable and always followed.

The READ MANUAL decal warns the operator to read this manual before operating the attachment.

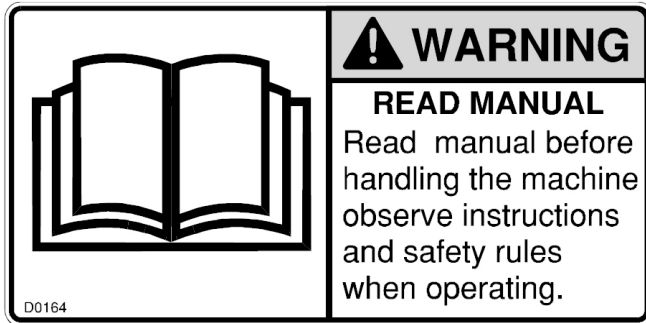

The ROTATING CUTTER decal warns the operator and bystanders to stay away during operation.

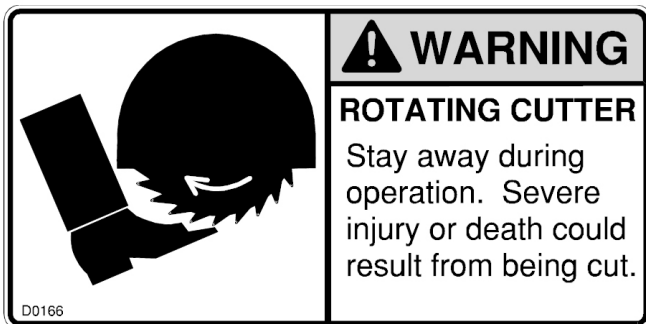

The FLYING OBJECTS decal warns the operator and bystanders to stay away during operation.



The INJECTION HAZARD decal warns the operator and bystanders to stay away during operation.

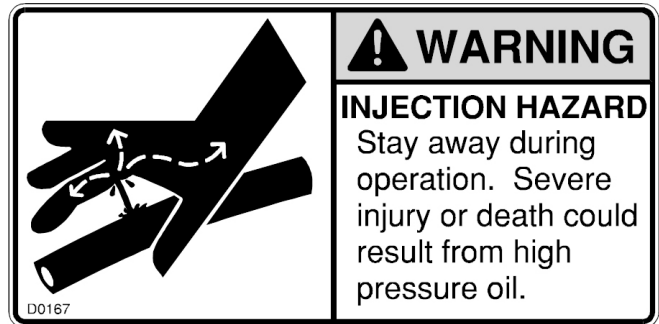

The CRUSHING HAZARD decal warns the operator and bystanders to stay away during operation.

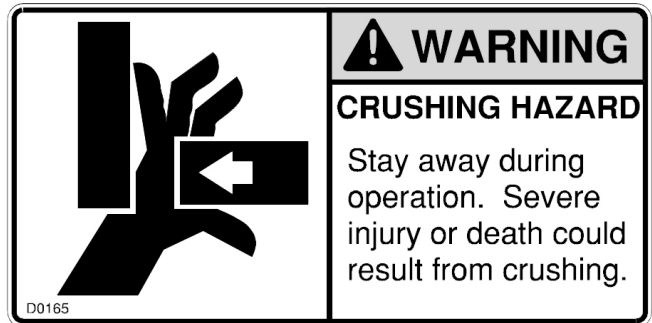

## 2. Safety

### 2.2 Safety Precautions

Before operating or conducting maintenance on this equipment, it is important to wear proper protection. Recommended safety equipment when operating and maintaining includes earplugs, eye protection, and a hard hat.

**NOTE:** Additional safety equipment may be required depending on the operating environment and worksite conditions.

Only qualified and trained personnel should operate, maintain, and service this attachment. Blue Diamond recommends that you inspect this equipment regularly for leaks, cracks, or other conditions that may impair proper usage of the equipment. Verify that all repairs have been completed and inspected prior to using the attachment under load.

#### Accidents are Preventable

It is the responsibility of the user to follow all local, state, and federal safety regulations.

- Call local utilities before you dig.
- Know the location of underground gas, water, and electrical lines.
- Inspect area for holes, drop-offs, or unstable ground.
- Know the weight limitations of operating surfaces and clearances.
- Remember: Safe operation begins with the operator.

Improper use of this equipment may result in personal injury, property damage, and/or damage to the equipment.

**NOTE:** Fasten the safety chain to your machine with very little slack.

### 2.3 Mandatory Shutdown Procedure

BEFORE cleaning, adjusting, lubricating, or servicing this unit, ALWAYS follow the MANDATORY SAFETY SHUTDOWN PROCEDURE:

1. Move the skid steer loader propulsion control levers to the “neutral position.
2. Move the loader throttle to the slow idle position. Shut off the attachment by shutting off the auxiliary and high flow hydraulic output.
3. Lower the loader lift arms completely and roll the attachment forward so it is securely resting on firm ground or the shop floor.
4. Engage the loader part brake.
5. Shut the engine off, and remove the ignition key.
6. Keep the key with you at all times when working on the unit so no one can start the engine without your knowledge.



#### WARNING



Before operating this equipment, the following safety information should be read and understood. In addition, each individual working with the equipment should be familiar with the safety precautions.



#### WARNING



Failure to follow the procedures before cleaning, adjusting, lubricating, or servicing this unit could lead to serious injury or death.

## 2. Safety

### 2.4 Safe Operating Procedures

A careful operator is the best protection against accidents. Most accidents involving operators of industrial equipment are caused by failure to observe basic safety precautions. Know the equipment and worksite before you operate. Familiarize yourself with the safety precautions listed below.



#### WARNING



The following precautions must be observed for the safety of the operator and/or service personnel.

1. Read and observe all safety information and decals on the prime mover and attachment **BEFORE** operating the unit!
2. Refer to the **SAFETY** section of your prime mover's operation manual and observe all safety recommendations set forth in the manual.
3. When loading, keep attachment as low to ramps and trailer as possible.
4. Always lower the loader arms fully before leaving the skid steer seat.
5. **BE SURE** to raise the attachment totally off the ground **BEFORE** side shifting.
6. **CAREFULLY** inspect **ALL** hydraulic hoses and connections on a routine basis; always use a piece of cardboard when searching for leaks.
7. **BE SURE** to exercise the above **MANDATORY SHUTDOWN PROCEDURE**, **BEFORE** proceeding with any work on the attachment.



#### WARNING



Never crawl under raised loader arms!



#### WARNING



Never use your hands as escaping fluid under pressure can penetrate the skin causing serious injury. If hydraulic fluid does penetrate the skin, seek immediate medical attention by a doctor familiar with this type of injury or gangrene may result.



#### WARNING



Never allow hands or feet near any working part of the attachment unless the mandatory shutdown procedure has been completed.

## 3. Setup

---



### **WARNING**



Read this entire manual as well as the decals on the attachment before attempting any maintenance, service, or setup of the unit.

Although the Blue Diamond® Cold Planer is supplied fully assembled, some simple checks should be performed before operation begins.

### **3.1 Safety Decals**

The safety decals existing on the attachment should be clearly readable always followed. The descriptions of the decals are shown in the “Safety Decals” section 2.1.

### **3.2 Hydraulic Couplers**

The planer has been shipped without the 2 required hydraulic quick couplers. Obtain correct brand and size and install them on the hoses.

The 160105 and 160110 are Low Flow Cold Planers which operate on the auxiliary flow of the prime mover. Since the auxiliary flow is reversible, be sure to operate the unit so the drum is spinning in the correct direction. The drum should spin in the direction the teeth are pointing.

### **3.3 Hoses/Fittings**

Hydraulic fittings are used to connect all attachment hoses. All fittings should be tight and free of hydraulic leaks. Hoses must be free of crimps or cuts that might result in leakage. Check your attachment before operation to make sure all hose routings are kink-free and allow for maximum movement of all extend, lift/lower, and/or swing motion required during normal operation.

### **3.4 Drum Assembly**

For proper operation, picks must be installed in every holder on the drum.



## 4. Operation

The cold planer is a hydraulically powered attachment intended for cutting asphalt or concrete surfaces. The performance of the attachment can vary greatly depending upon how it is used and operated. Therefore, the recommended operating procedures contained within this manual should be followed at all times for maximum productivity.

Prior to operating the attachment, read this entire manual. Follow all safety guidelines in this manual and safety decals on the unit. Make sure that all guards, shields, and decals are in place and in good condition prior to operation.

See page 26 for minimum flow requirements for this model.



**CAUTION**



Insufficient hydraulic power will result in poor performance. Check auxiliary flow per factory specifications.

### 4.1 Attaching to Prime Mover

To attach the unit to the prime mover, start the prime mover engine and rotate the coupler out. Pull both coupler levers up to the vertical position. Move the machine forward and pick up the attachment. Rotate the attachment back and push both coupler levers completely down. Make sure the two wedges are completely down and engaged. Be sure pins and latch handles are secure before operating boom and bucket. Always refer to operating instructions in the prime mover manual.

In attaching the unit to the machine, ensure that all hydraulic hoses are coupled securely to the quick couplers. Two hoses are to be connected, pressure and return.

### To Operate:

1. Enter prime mover and fasten seat belt.
2. Make sure the area is clear of bystanders and other workers.
3. Start the prime mover and engage the low flow hydraulic circuit at idle.
4. Adjust the planer's title and depth using the manual jacks with the hand screw. Sideshift as needed using the manual diverter valve located on the sideshift frame.
5. Move the throttle to the full rpm position and keep it there during the milling operations. Lower the drum into the cut. Move forward at a speed that will allow the drum to move efficiently without stalling.

**NOTE:** Milling speed will depend on tooth condition, age, and density of the material, aggregate size and ambient temperature.



**CAUTION**



The signal word **CAUTION** on the machine and in the manuals indicates a potentially hazardous situation which, if not avoided, may result in minor or moderate injury. It may also be used to alert against unsafe practices.

## 5. Maintenance

Proper maintenance of the attachment will result in longer life and the more productive and cost effective operation. There are two basic categories of maintenance required: pick/holder replacement and component lubrication.

For proper operation, the picks should be checked each four (4) hours and lubricated daily to ensure that they can freely rotate in their holders



### WARNING



Before performing any maintenance on the unit, perform the mandatory shutdown procedure.



### WARNING



Never drive the pick by striking directly on the end of the pick as this can cause the pick to chip and cause injury or create small stress fractures in the pick resulting in premature wear.



### WARNING



Always wear safety glasses when performing this operation. Hardened tools and picks can shatter causing injury.

### 5.1 Pick/Holder Replacement

As regular use takes place, normal wear of the carbide picks will occur with the outer most picks wearing first. The pick tool included with the cold planer should be used to remove the picks from the cast holders. In the event the pick tool is not available, any hardened punch or tool allowing access to the bottom of the holders can be used.



### WARNING



Welder must be grounded directly to drum during pick holder replacement or severe bearing damage will result.

A length of pipe with a 25mm inside diameter can be placed over the pick to protect it from a direct hit. Striking a small piece of wood placed on the pick to absorb the shock will prevent damage.

The factory installed carbide pick chosen for use is a general purpose pick as the cold planer is designed for both asphalt and concrete applications. Picks designed for extended periods of concrete cutting are available from the factory or your dealer.

To prevent the picks from seizing in the holders, the picks should be sprayed with a lubricant at the end of each day. This will break down the asphalt build up in the holders and prevent premature wear by allowing the picks to rotate in the holders. Excess lubricant should be caught in a collection pan and properly disposed.

If the pick remains in the holder beyond its intended replacement point, it reduces the cutting performance and will not protect the holder. Inspect the cutting drum every hour of operation. Check the picks and holders for wear. If the picks are worn enough to indicate slight holder wear, replace the picks.

## 5. Maintenance



### WARNING



Before servicing this unit, the mandatory safety shutdown procedure must be completed. See “Safety” section.

### 5.2 Lubrication

On the 160105 and 106110 cold planers there are 5 grease points.

1. On the rear of the unit; two grease zerks on the two side shift tubes.
2. On the non motor side of the unit; a bearing with a grease zerk.
3. Two grease zerks are on the depth jack and tilt screw jack.
4. These 5 grease points should be greased each day.

For pick maintenance, consult 5.1 on page 10.

### 5.3 Drum Removal



### WARNING



Exercise extreme caution during this operation to prevent tipping of the unit.

1. Perform mandatory shutdown procedure with the cold planer adjusted to the maximum depth. Ensure that planer drum is sitting on a stable surface and is chocked to prevent movement.
2. Disconnect the two hydraulic lines connected to the motor.

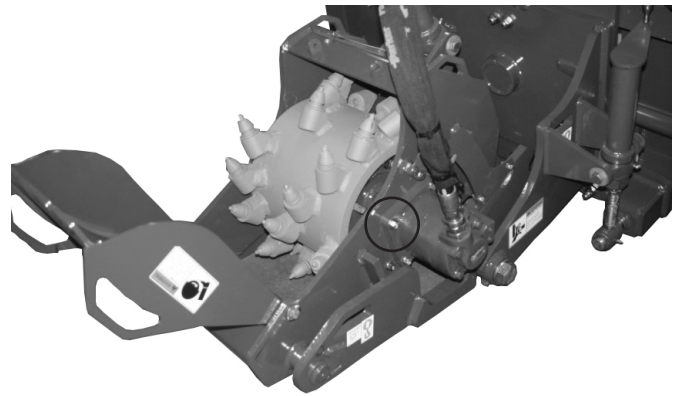

3. Remove the four 1/2” motor bolts that fasten the motor to the unit.

4. Remove the four 1/2” bolts that fasten the bearing to the housing.

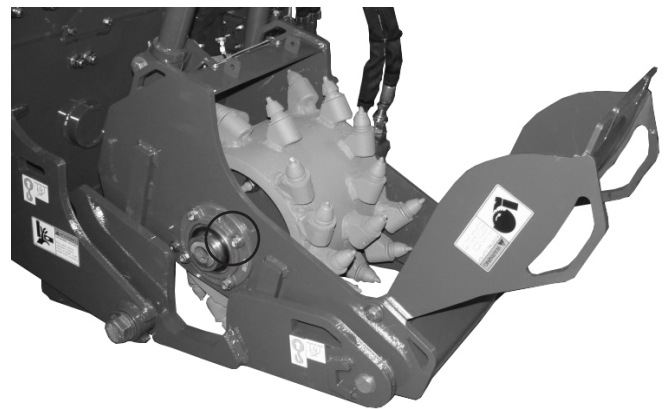

5. Lift cold planer chassis off of drum using a hoist.

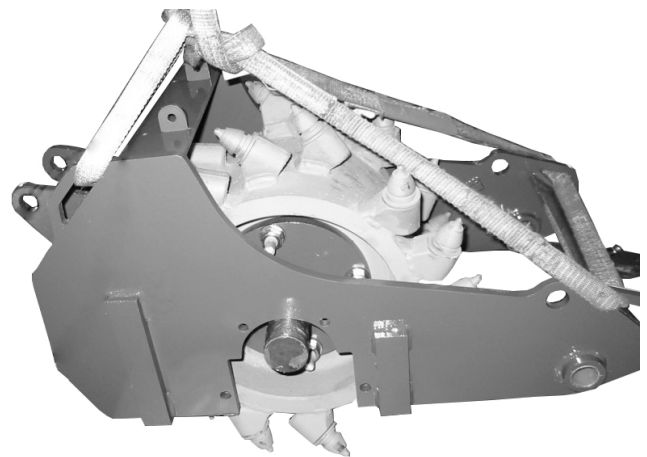

6. Reverse steps for reassembly.

## 5. Maintenance

### 5.4 Drum Motor Removal

1. Remove the drum from the planer chassis.

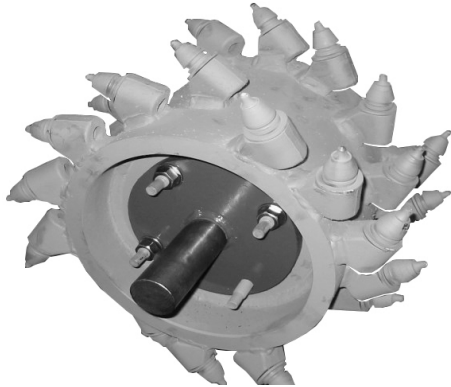

2. Remove (4) deadshaft nuts from the right side of the drum.

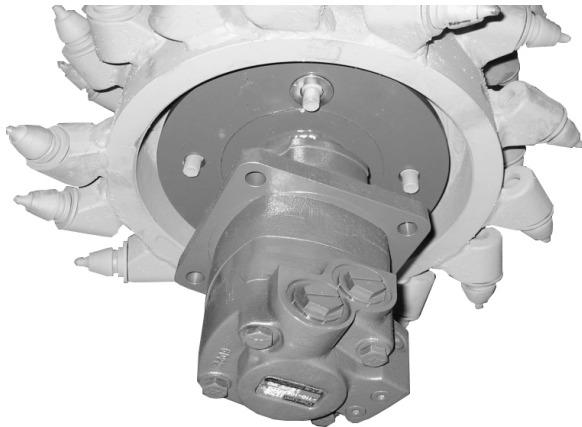

3. Remove the (4) nuts from the left side of the drum and remove the motor assy.

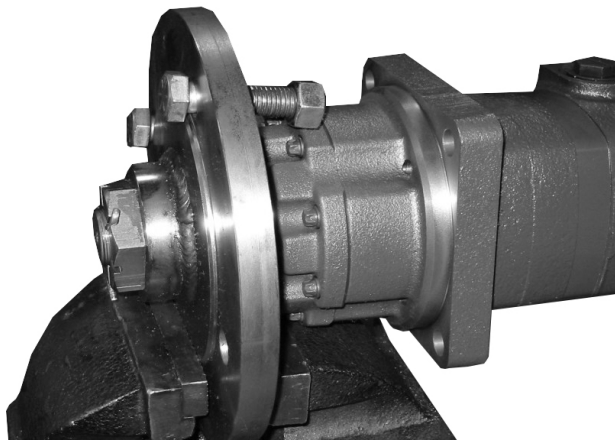

4. Remove the cotter pin and nut on the motor shaft and remove the hub.

5. Reverse steps for reassembly.



#### WARNING



If the drum does not remain on the floor, lower the planer, shut the engine off, remove the ignition key and review steps 1 thru 5. Do not attempt to dislodge the drum while the planer frame is in the raised position. Never place hands or any part of your body in, around, or under the drum, as it may fall causing serious injury.



#### WARNING



Components are extremely heavy and can cause serious injury if proper lifting techniques are not used.

## 6. Diagrams & Parts

### 6.1 Chassis Parts

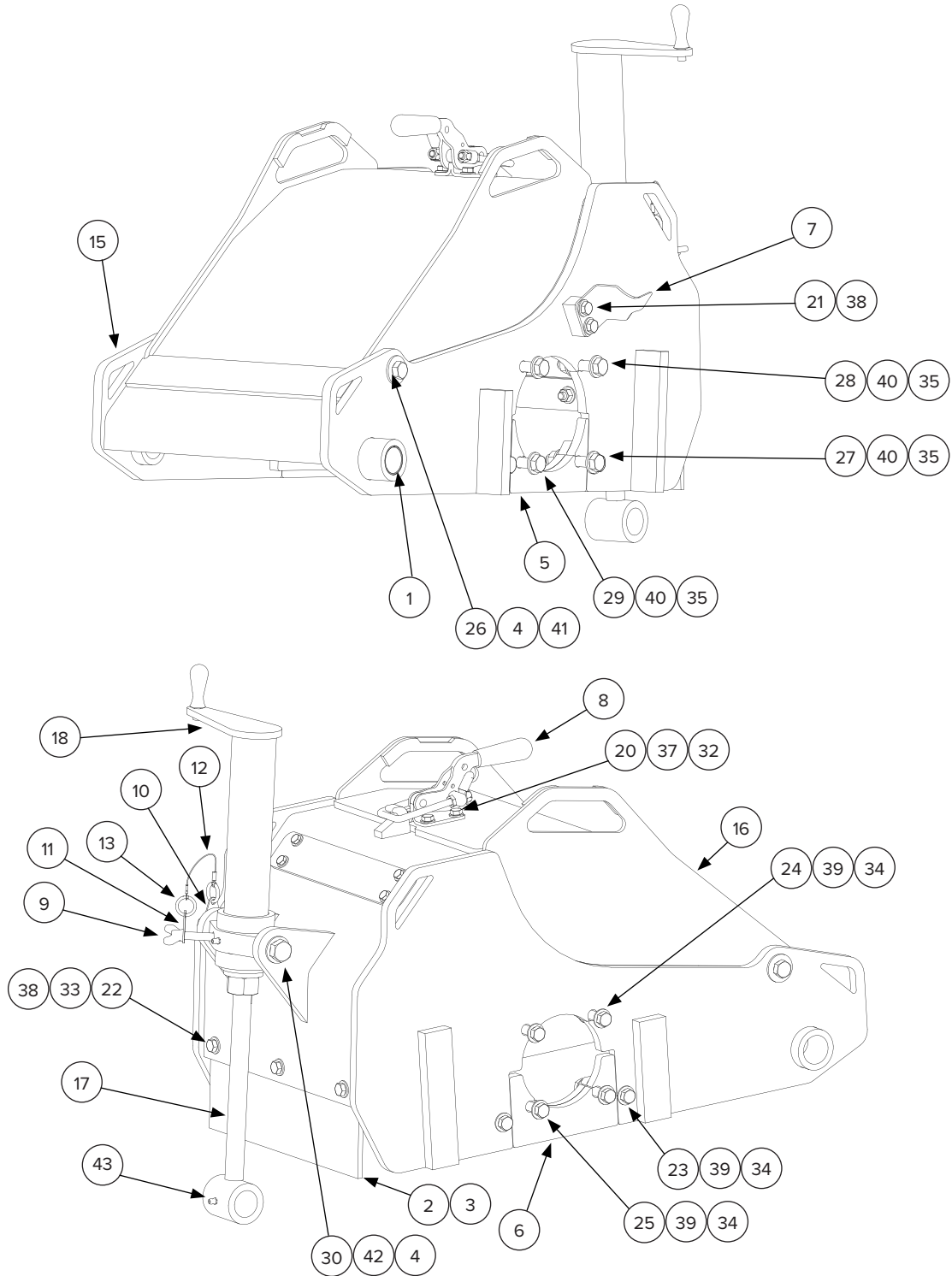

ITEM NO.	PARTS DESCRIPTION	PART # 160105	PART # 160110	QTY
1	BEARING, DU 1.25 PIN X 1.25 WIDTH	260377	260377	1
2	BELTING, RUBBER	260160	260161	1
3	PLATE, BELTING RETAINER	260162	260163	1
4	BUSHING, SHROUD BOLT	260085	260085	4
5	WELDMENT, CHASSIS GUSSET	260164	260164	1

## 6. Diagrams & Parts

### 6.1 Chassis Parts – 160105 & 160110

ITEM NO.	PARTS DESCRIPTION	PART # 160105	PART # 160110	QTY
6	WELDMENT, CHASSIS GUSSET	260165	260165	1
7	PLATE, DEPTH INDICATOR	260373	260373	1
8	LATCH ASSEMBLY, DRAW	260040	260040	1
9	SCREW, WING 3/8-16 X 2	299510	299510	1
10	PLATE, CABLE RETAINER	260393	260393	1
11	PLATE, CABLE RETAINER	260394	260394	1
12	CABLE, SHROUD RETAINER PIN	260120	260120	1
13	RING, SPLIT	260399	260399	2
14	PLATE, WATER SPRAY BAR COVER	260166	260400	1
15	WELDMENT, CHASSIS	260332	260331	1
16	CHASSIS SHROUD WELDMENT	260345	260343	1
17	WELDMENT, JACK MALE	260322	260322	1
18	WELDMENT, JACK FEMALE	260122	260122	1
19	BOLT, 1/4-20 X 1.00 PLATED	216403	216403	4
20	BOLT, 5/16-18 X 1.00 PLATED	299317	299317	4
21	BOLT, 3/8-16 X 0.75 PLATED	299424	299424	2
22	BOLT, 3/8-16 X 1.50 PLATED	216465-1	216465-1	3
23	BOLT, 7/16-14 x 1.75 PLATED	299434	299434	2
24	BOLT, 7/16-14 X 2.00 PLATED	299452	299452	2
25	BOLT, 7/16-14 X 2.50 PLATED	299443	299443	2
26	BOLT, 1/2-13 x 1.75 PLATED	216491	216491	2
27	BOLT, 1/2-13 X 2.00 PLATED	299433	299433	2
28	BOLT, 1/2-13 X 2.25 PLATED	299433-2.25	299433-2.25	2
29	BOLT, 1/2-13 X 2.75 PLATED	299461 (NOTE A)	299461 (NOTE A)	2
30	BOLT, 5/8-11 X 1.75 PLATED	299440	299440	2
31	NUT, 1/4-20 PLATED	216404	216404	4
32	NUT, 5/16-18 PLATED	299571	299571	4
33	NUT, 3/8-16 PLATED	299572	299572	3
34	NUT, 7/16-14 PLATED	299573	299573	6
35	NUT, 1/2-13 PLATED	299574	299574	6
36	WASHER, 1/4 NARROW PLATED	216405	216405	8
37	WASHER, 5/16 NARROW PLATED	216547	216547	8
38	WASHER, 3/8 NARROW PLATED	216495	216495	8
39	WASHER, 7/16 NARROW PLATED	299716	299716	12
40	WASHER, 1/2 NARROW PLATED	216427	216427	12
41	WASHER, 1/2 WIDE PLATED	299717	299717	2
42	WASHER, 5/8 NARROW PLATED	299844	299844	2
43	ZERK, 1/4-28 STRAIGHT	232079	232079	3

NOTE A: FOR PLANERS BUILT AFTER APRIL 2020, BOLT WAS CHANGED TO 299322 BOLT, SOCKET HEAD 1/2-13X3.00 PLATED.

## 6. Diagrams & Parts

### 6.2 Depth Skid Parts

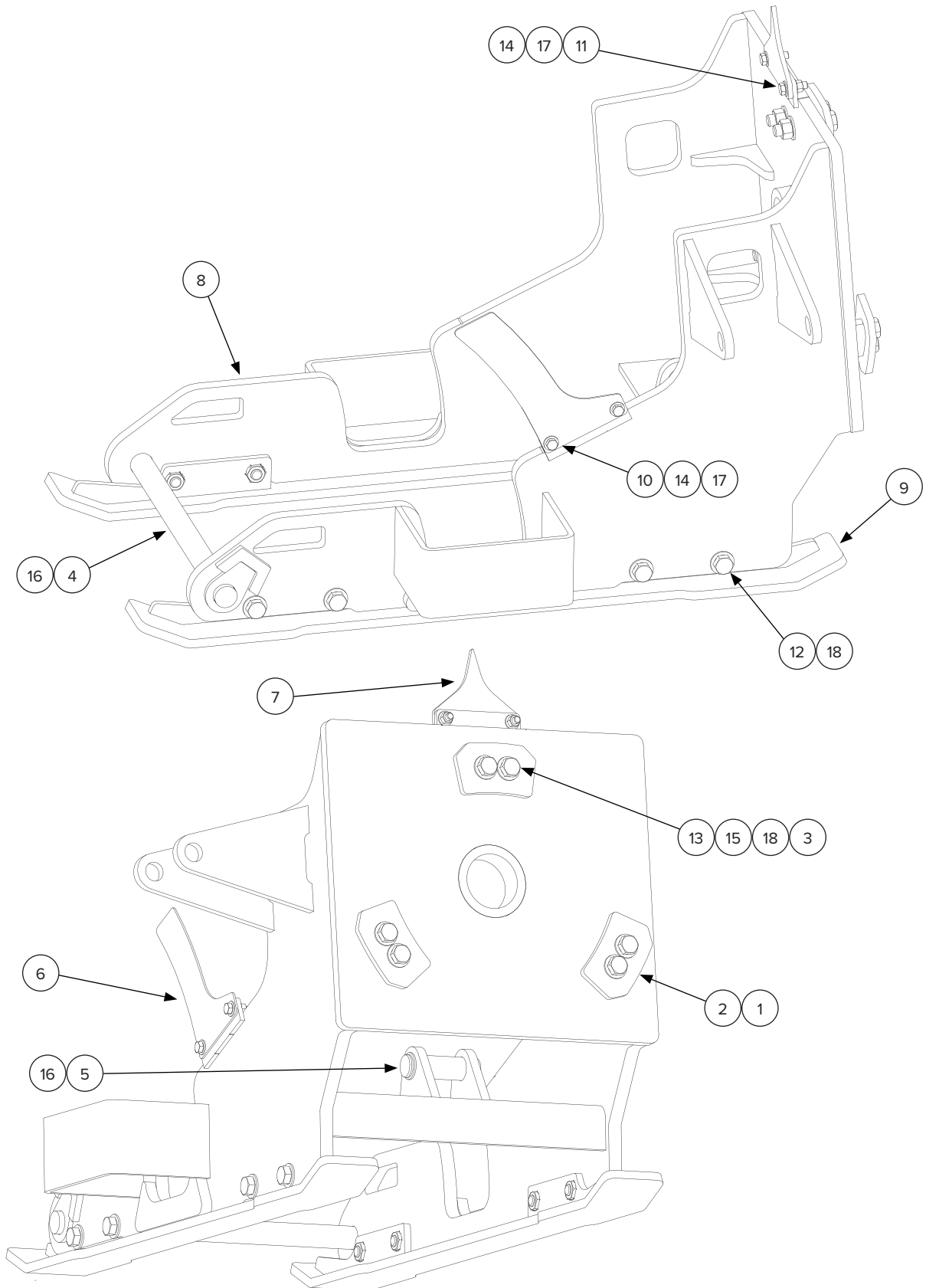



## 6. Diagrams & Parts

### 6.2 Depth Skid Parts

ITEM NO.	PARTS DESCRIPTION	PART # 160105	PART # 160110	QTY
1	PLATE, PIVOT SPACER	260064	260064	3
2	PLATE, PIVOT RETAINER	260061	260061	3
3	PLATE, PIVOT SPACER	260068	260068	3
4	WELDMENT, CHASSIS PIN	260102	260346	1
5	PIN, SIDE SHIFT/LF JACK	260307	260307	1
6	PLATE, DEPTH DECAL	260381	260381	1
7	PLATE, TILT INDICATOR	260378	260378	1
8	WELDMENT, DEPTH SKID	260154	260151	1
9	WELDMENT, WEAR SKID	260347	260347	2
10	BOLT, 3/8-16 X 1.00 PLATED	299423	299423	2
11	BOLT, 3/8-16 X 1.25 PLATED	216445	216445	2
12	BOLT, 5/8-11 X 1.50 PLATED	299462	299462	8
13	BOLT, 5/8-11 X 3.00 PLATED	299449	299449	6
14	NUT, 3/8-16 PLATED	299572	299572	4
15	NUT, 5/8-11 PLATED	299575	299575	6
16	RETAINING RING, EXTERNAL 1.25" DIA.	260029	260029	3
17	WASHER, 3/8 NARROW PLATED	216495	216495	8
18	WASHER, 5/8 NARROW PLATED	299844	299844	20



## 6. Diagrams & Parts

### 6.3 Attach Group

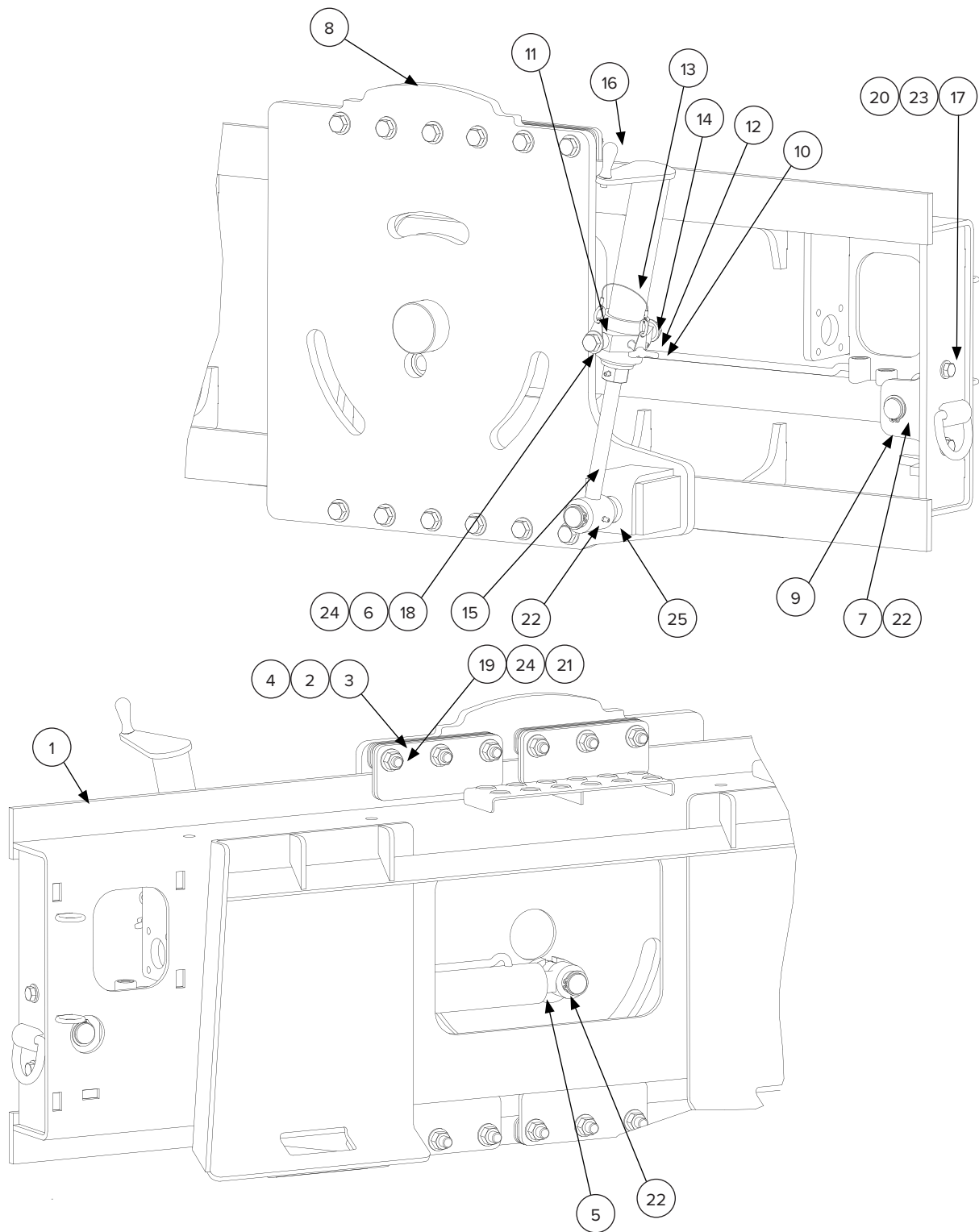

## 6. Diagrams & Parts

### 6.3 Attach Group

ITEM NO	PARTS DESCRIPTION	PART # 160105	PART # 160110	QTY
1	WELDMENT, ATTACH	260326	260326	1
2	PLATE, SIDE SHIFT SPACER	260062	260062	12
3	PLATE, SIDE SHIFT RETAINER	260063	260063	4
4	PLATE, SIDE SHIFT SPACER (PLASTIC)	260067	260067	2
5	CYLINDER, SIDESHIFT (SEAL KIT: 260026)	260022	260022	1
6	BUSHING, SHROUD BOLT	260085	260085	2
7	PIN, SIDE SHIFT / LF JACK	260307	260305	1
8	WELDMENT, SIDESHIFT	260333	260333	1
9	PLATE, CYLINDER BRACKET	260365	260365	1
10	SCREW, WING 3/8-16 X 2	299510	299510	1
11	PLATE, CABLE RETAINER	260393	260393	1
12	PLATE, CABLE RETAINER	260394	260394	1
13	CABLE, SHROUD RETAINER PIN	260120	260120	1
14	RING, SPLIT	260399	260399	2
15	WELDMENT, JACK MALE	260322	260322	1
16	WELDMENT, JACK FEMALE	260122	260122	1
17	BOLT, 1/2-13 x 1.75 PLATED	216491	216491	2
18	BOLT, 5/8-11 X 1.75 PLATED	299440	299440	2
19	BOLT, 5/8-11 X 3.00 PLATED	299449	299449	12
20	NUT, 1/2-13 PLATED	299574	299574	2
21	NUT, 5/8-11 PLATED	299575	299575	12
22	RETAINING RING, EXTERNAL 1.25" DIA.	260029	260029	4
23	WASHER, 1/2 NARROW PLATED	216427	216427	4
24	WASHER, 5/8 NARROW PLATED	299844	299844	26
25	ZERK, 1/4-28 STRAIGHT	232079	232079	3

## 6. Diagrams & Parts

### 6.4 Drivetrain and Drum Group

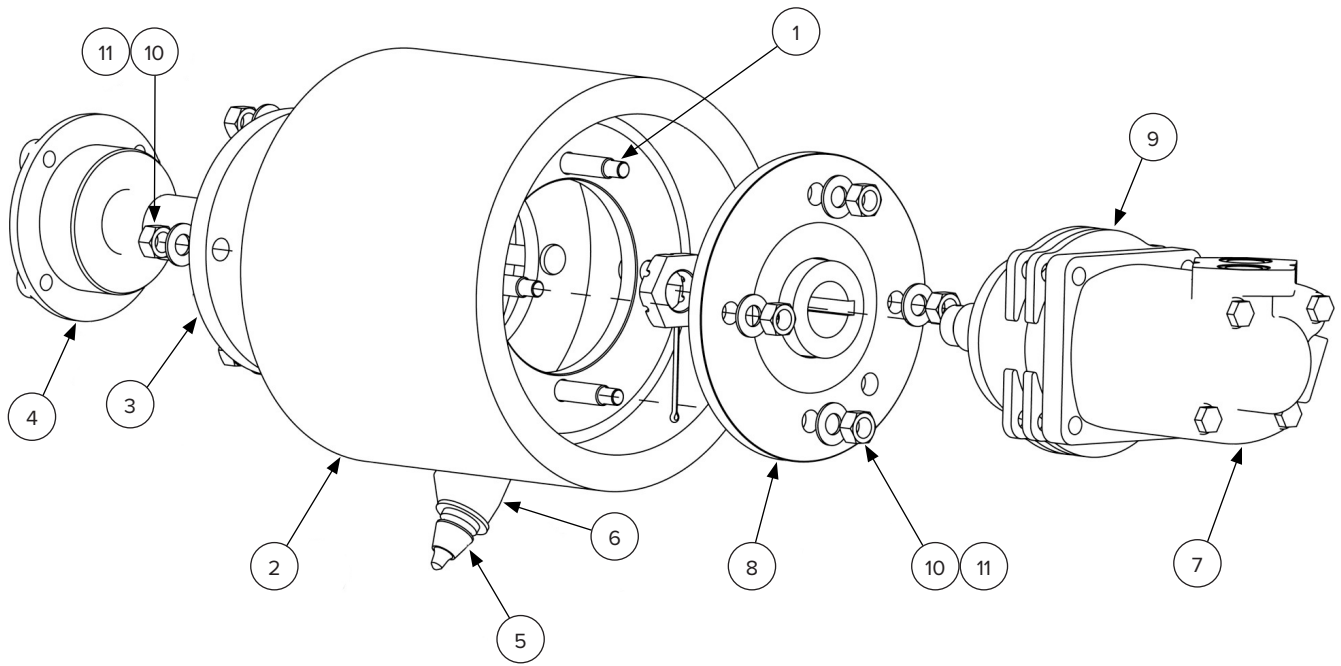

## 6. Diagrams & Parts

### 6.4 Drivetrain and Drum Group

ITEM NO	PARTS DESCRIPTION	PART # 160105	PART # 160110	QTY
1	BOLT, 5/8-11 X 2.25 RND HD, RBD NECK	260172	260172	8
2	ASSEMBLY, DRUM WITH PICKS & STUDS	260173	260173	1
3	WELDMENT, DEAD SHAFT	260174	260174	1
4	BEARING, DEAD SHAFT	216479	216479	1
5	PICK, ASPHALT (NOTE A)	260001	260001	1
6	HOLDER, PICK (NOTE A)	260003	260003	1
7	MOTOR, DRUM DRIVE (SEAL KIT: 260155)	260150	260150	1
8	WELDMENT, MACHINED MOTOR HUB	260152	260152	1
9	PLATE, MOTOR SPACER CPLF	260153	260153	4
10	NUT, 5/8-11 PLATED	299575	299575	8
11	WASHER, 5/8 NARROW PLATED	299844	299844	8

NOTE A: QUANTITY VARIES

160105: 30

160110: 38

## 6. Diagrams & Parts

### 6.5 Hydraulic Group

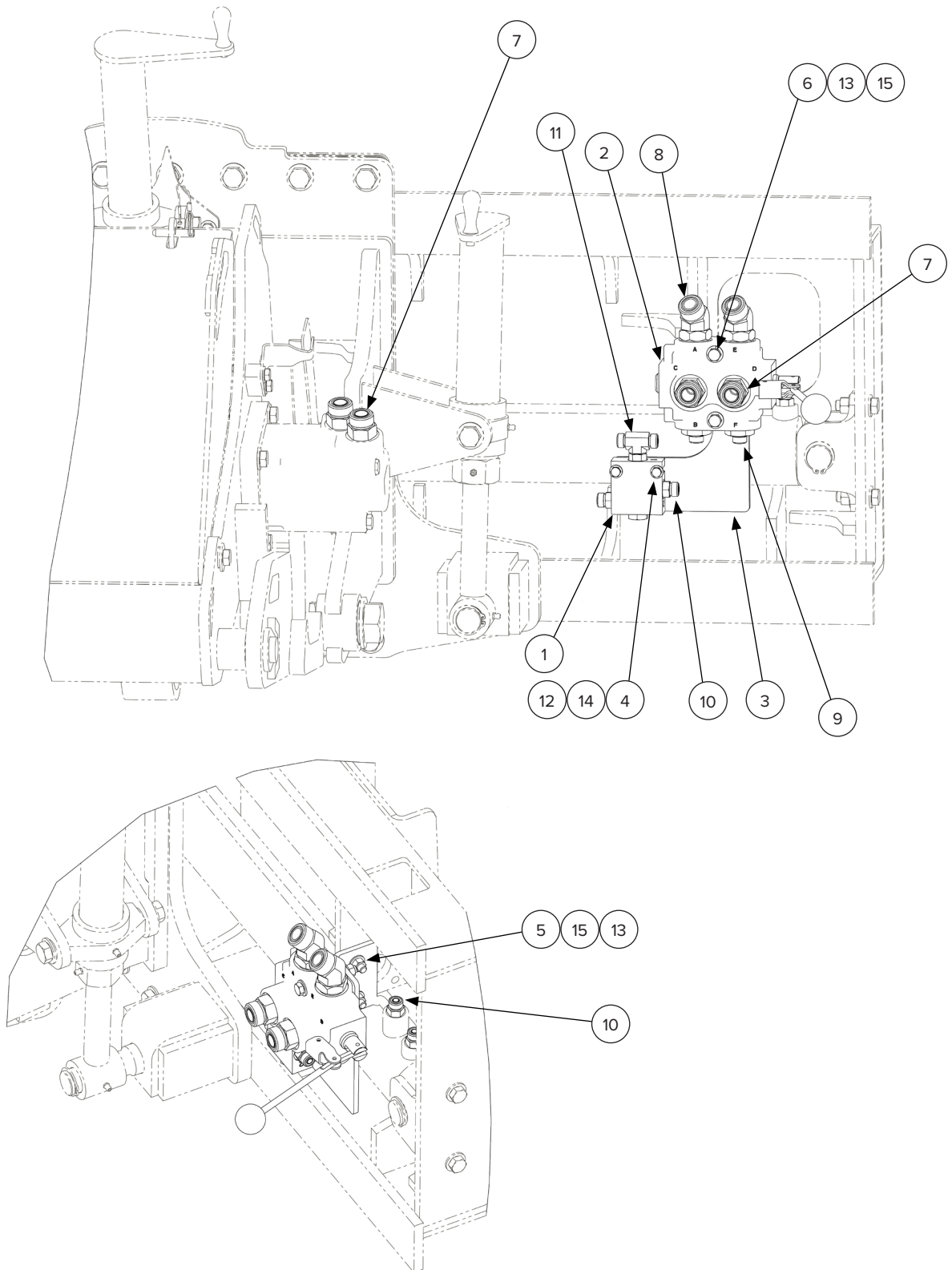

## 6. Diagrams & Parts

### 6.5 Hydraulic Group

ITEM NO	PARTS DESCRIPTION	PART # 160105 &	QTY
1	ASSEMBLY, CHECK VALVE	260350	1
2	ASSEMBLY, DIVERTER VALVE	260341	1
3	PLATE, VALVE MOUNT	260368	1
4	BOLT, 1/4-20 x 2.00 PLATED	299415	2
5	BOLT, 3/8-16 X 1.50 PLATED	216465-1	2
6	BOLT, 3/8-16 X 3.00 PLATED	299425	2
7	FITTING, ELBOW 12 ORFS 12 STOR 45 DEG.	295020-M12FS-M12ORB	4
8	FITTING, STRAIGHT 12 ORFS 12 ST OR	260303	2
9	FITTING, STRAIGHT 6 ORFS 12 ST OR	295010-M06FS-M12ORB	2
10	FITTING, TEE -6 STOR -6 ORFS -6 ORFS	295050-M06FS-M06FS-M06ORB	1
11	FITTING, STRAIGHT 6ORFS 6SAE-ORB	295010-M06FS-M06ORB	2
12	NUT, 1/4-20 PLATED	216404	2
13	NUT, 3/8-16 PLATED	299572	4
14	WASHER, 1/4 NARROW PLATED	216405	4
15	WASHER, 3/8 NARROW PLATED	216495	8

## 6. Diagrams & Parts

### 6.6 Decal Group

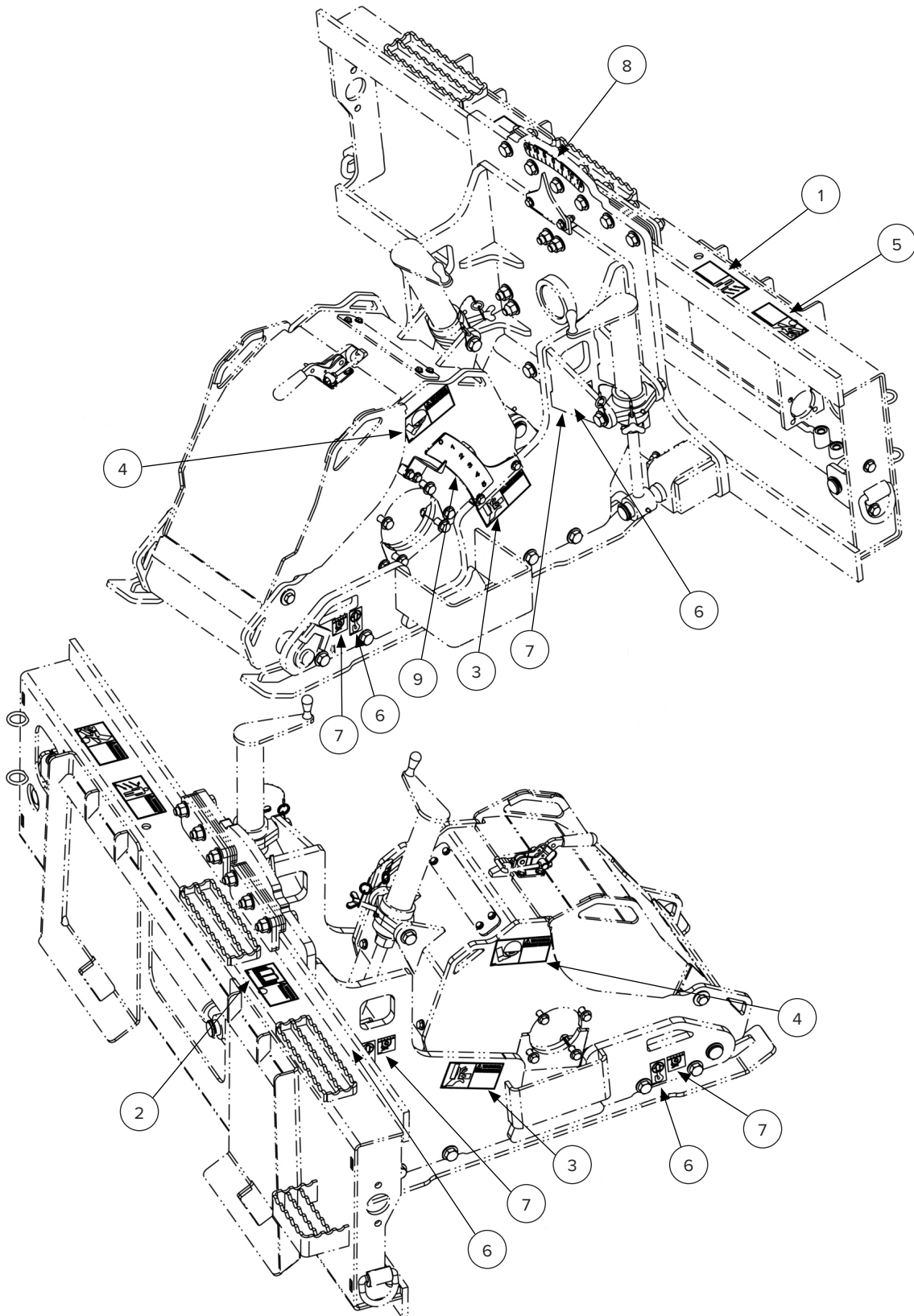

## 6. Diagrams & Parts

---

### 6.5 Decal Group

ITEM NO	PARTS DESCRIPTION	PART #	QTY
1	DECAL, FLYING OBJECTS	260178	1
2	DECAL, READ MANUAL	260179	1
3	DECAL, CRUSHING HAZARD	260180	2
4	DECAL, ROTATING CUTTER	260181	2
5	DECAL, INJECTION HAZARD	260182	1
6	DECAL, LIFT POINT	260183	4
7	DECAL, TIE DOWN	260184	4
8	DECAL, TILT INDICATOR	260375	1
9	DECAL - LOW FLOW DEPTH	260376	1



## 6. Diagrams & Parts

### 6.7 Hydraulic Schematic

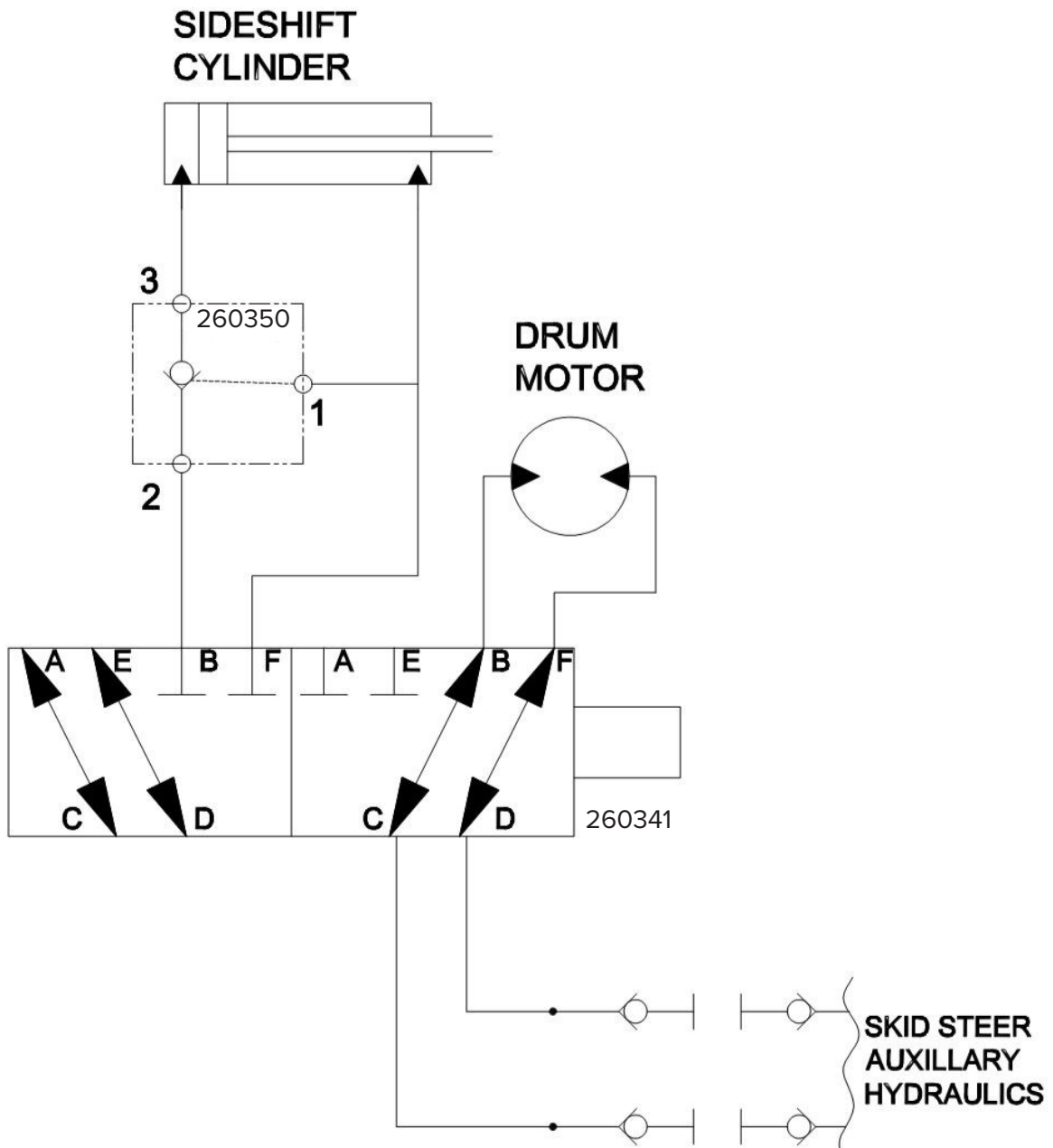

## 7. Specifications

---

### 7.1 Specification Table

	160105	160110
Cutting Width	12 inches	16 inches
Cutting Depth	0 – 5 inches	0 – 5 inches
Min. Hydraulic Flow	15 GPM	15 GPM
Minimum Pressure	2000 PSI	2000 PSI
Weight	1220 lbs.	1250 lbs.



## Warranty

### MANUFACTURER'S LIMITED WARRANTY

BLUE DIAMOND® ATTACHMENTS, a manufacturer of quality attachments, warrants new BLUE DIAMOND® ATTACHMENTS products and/or attachments at the time of delivery to the original purchaser, to be free from defects in material and workmanship when properly set up and operated in accordance with the recommendations set forth by BLUE DIAMOND® ATTACHMENTS, LLC.

BLUE DIAMOND® ATTACHMENTS liability for any defect with respect to accepted goods shall be limited to repairing the goods at a BLUE DIAMOND® ATTACHMENTS designated location or at an authorized dealer location, or replacing them, as BLUE DIAMOND® ATTACHMENTS shall elect. The above shall be in accordance with BLUE DIAMOND® ATTACHMENTS warranty adjustment policies. BLUE DIAMOND® ATTACHMENTS obligation shall terminate twelve (12) months for the Low Flow Cold Planer after the delivery of the goods to original purchaser.

This warranty shall not apply to any machine or attachment which shall have been repaired or altered outside the BLUE DIAMOND® ATTACHMENTS factory or authorized BLUE DIAMOND® ATTACHMENTS dealership or in any way so as in BLUE DIAMOND® ATTACHMENTS judgment, to affect its stability or reliability, nor which has been subject to misuse, negligence or accident beyond the company recommended machine rated capacity.

### WARRANTY CLAIM

To submit a warranty claim, a claim must be filed with BLUE DIAMOND® ATTACHMENTS before work is performed. The BLUE DIAMOND® PRODUCT SUPPORT TEAM will advise repairs and applicable parts exchanges. Tampering with the failed part may void the warranty. This warranty does not include freight or delivery charges incurred when returning machinery for servicing. Dealer mileage, service calls, and pickup/delivery charges are the customers' responsibility.

### EXCLUSIONS OF WARRANTY

Except as otherwise expressly stated herein, BLUE DIAMOND® ATTACHMENTS makes no representation or warranty of any kind, expressed or implied, AND MAKES NO WARRANTY OF MERCHANTABILITY IN RESPECT TO ITS MACHINERY AND/OR ATTACHMENTS ARE FIT FOR ANY PARTICULAR PURPOSE. BLUE DIAMOND® ATTACHMENTS shall not be liable for incidental or consequential damages for any breach or warranty, including but not limited to inconvenience, rental of replacement equipment, loss of profits or other commercial loss. Upon purchase, the buyer assumes all liability for all personal injury and property resulting from the handling, possession, or use of the goods by the buyer.

No agent, employee, or representative of BLUE DIAMOND® ATTACHMENTS has any authority to bind BLUE DIAMOND® ATTACHMENTS to any affirmation, representation, or warranty concerning its machinery and/or attachments except as specifically set forth herein.

This warranty policy supersedes any previous documents.

**NOTE:** Blue Diamond® Attachments is a trademark of BLUE DIAMOND® ATTACHMENTS



**QUALITY | DEPENDABILITY | INTEGRITY**

Blue Diamond® Attachments  
4512 Anderson Road, Knoxville, TN 37918  
888-376-7027