

High Flow Severe Duty & High Flow Cold Planers

Operation and Maintenance Manual

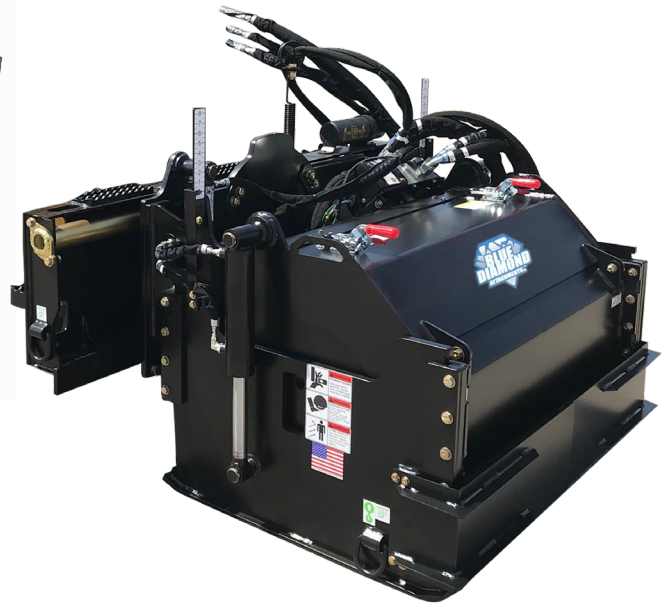

Register your
WARRANTY
within 30 days
of purchase

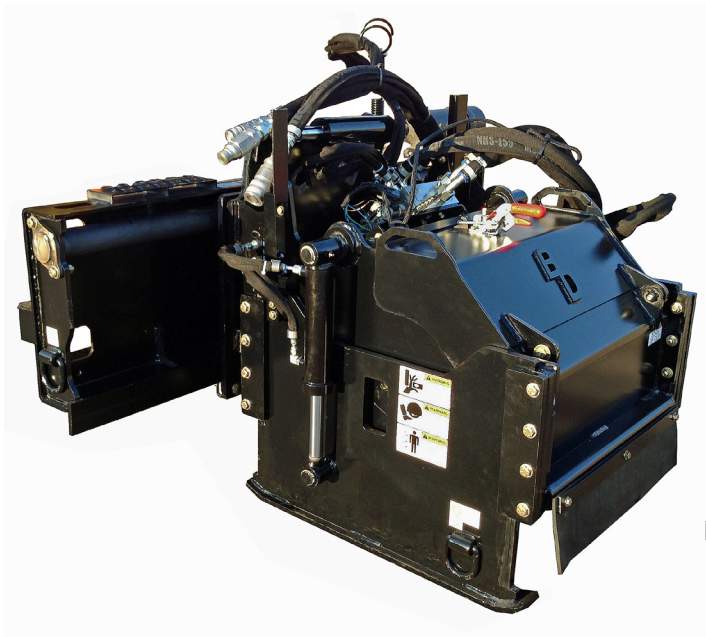

888-376-7027 | BlueDiamondAttachments.com



BD-092

Introduction: Owner Information

Thank you for your decision to purchase a Blue Diamond® High Flow Cold Planer. To ensure maximum performance of your equipment, it is mandatory that you thoroughly study the Operator's manual and follow the recommendations. Proper operation and maintenance are essential to maximize equipment life and prevent personal injury.

Operate and maintain this equipment in a safe manner and in accordance with all applicable local, state, and federal codes, regulations and /or laws. Follow all on-product labeling and instructions.

Make sure that all personnel have read this Operator's Manual and thoroughly understand safe and correct operating, installation and maintenance procedures.

Blue Diamond is continually working to improve its products. Blue Diamond reserves the right to make any improvements or changes as deemed practical and possible without incurring any responsibility or obligation to make any changes or additions to equipment sold previously.

Although great care has been taken to ensure the accuracy of this publication, Blue Diamond makes no warranty or guarantee of any kind, written or expressed, implied or otherwise with regard to the information contained within this manual. Blue Diamond assumes no responsibility for any errors that may appear in this manual and shall not be liable under any circumstances for incidental, consequential or punitive damages in connection with, or arising from the use of this manual.

Keep this manual available for frequent reference. All new operators or owners must review the manual before using the equipment and annually thereafter. Contact your Blue Diamond Attachments Dealer for assistance, information, or additional copies of the manual. Contact www.bluediamondattachments.com or call 888-376-7027 for a complete list of dealers in your area.

Serial Number Location:

Please record attachment information in the space provided for future reference.



Model Number: _____

Serial Number: _____

Dealer Name: _____

Dealer Number: _____

Date of Purchase: _____

The Serial Number is located on the right side of the attachment, on the rear of the mount plate.

Always use your serial number when requesting information or when ordering parts.

NOTE: The directions left, right, front and rear, as mentioned throughout this manual, are as viewed from the operator's position.

Revision Date: 09.12.23

Blue Diamond® Attachments

Table of Contents

1. About this Manual	4
1.1 Hazard Notices used in this manual	4
1.2 Servicing Drivetrain Components	4
2. Safety	5-9
2.1 General Safety	5
2.2 Safety Decals	6
2.3 Safety Precautions	7
2.4 Mandatory Shutdown Procedure	7
3. Setup	8-9
4. Operation	10-11
4.1 Attaching the Loader	9
4.2 Basic Operation	10
4.3 Drum Removal	11
5. Maintenance	12-15
5.1 General Maintenance	12
5.2 Cutting Drum Maintenance	12
5.3 Cold Planer Lubrication	14
5.4 Drum Removal	15
5.5 Planetary Gearbox Removal	15
6. Diagram & Parts	16-38
6.1 Chassis Parts: 18" & 24" Models	16
6.2 Chassis Parts: 30", 40", & 48" Models	18
6.3 Drivetrain Parts	20
6.4 Drivetrain Parts for Severe Duty Models	22
6.5 Attach Parts for 18" & 24" Models	24
6.6 Attach Parts for 30", 40", & 48" Models	26
6.7 Decal Locations	28
6.8 Hydraulic Parts	30
6.9 Valve 3-Line Dual Depth Assembly	32
6.10 3-Line Hydraulic Schematic	33
6.11 Electrical Parts	34
6.12 Electrical Schematics	35
7. Troubleshooting	40
8. Specifications	41-42
8.1 Attachment Specifications	41
8.2 Torque Specifications	42
9. Warranty	43

1. About this Manual

About this Manual

This manual contains information about the usage and maintenance required for the equipment. This document must be available for review by the operator before using the attachment to ensure proper safety, maintenance, and usage.

1.1 Hazard Notices Used in this Manual

The following hazard notices are used in this document:

NOTE: Notes are used to indicate important information. This information may be repeated in other areas of the manual.



The signal word **IMPORTANT** identifies procedures which must be followed to avoid damage to the machine.



The signal word **CAUTION** on the machine and in the manuals indicates a potentially hazardous situation which, if not avoided, may result in minor or moderate injury. It may also be used to alert against unsafe practices.



The signal word **WARNING** on the machine and in the manuals indicates a potentially hazardous situation which, if not avoided, could result in death or serious injury.



The signal word **DANGER** on the machine and in the manuals indicates a hazardous situation which, if not avoided, will result in death or serious injury.

1.2 Servicing Drivetrain Components

Detailed repair of the drive train components such as the hydraulic motor and gearbox is not covered in this manual. Contact your Blue Diamond® dealer for information about repairing these components during the warranty period.

Any unauthorized work performed on these components during the warranty period may void your warranty.

2. Safety

2.1 General Safety

A careful operator is the best protection against accidents. Most accidents involving operators of industrial equipment are caused by failure to observe basic safety precautions. Know the equipment and worksite before you operate. Familiarize yourself with the safety precautions listed below.



WARNING



The following precautions must be observed for the safety of the operator and/or service personnel.

1. Read and observe all safety information and decals on the skid steer loader and attachment **BEFORE** operating the unit!
2. Refer to the **SAFETY** section of your skid loaders operator's manual and observe all safety recommendations set forth in the manual.
3. When loading, keep attachment as low to ramps and trailer as possible.
4. Always lower the loader arms fully before leaving the skid steer seat.
5. **BE SURE** to raise the attachment off the ground **BEFORE** side shifting.
6. **CAREFULLY** inspect **ALL** hydraulic hoses and connections on a routine basis; always use a piece of cardboard when searching for leaks.
7. **BE SURE** to exercise the above **MANDATORY SAFETY SHUTDOWN** procedure, **BEFORE** proceeding with any work on the attachment.



WARNING



Never crawl under raised loader arms.



WARNING



Never allow hands or feet near any working part of the attachment unless the mandatory safety shutdown procedure has been completed.



WARNING



Never use your hands or other body part to check for hydraulic fluid leaks. Escaping fluid under pressure can penetrate the skin causing serious injury. If hydraulic fluid penetrates the skin, seek treatment from a doctor familiar with this type of condition or serious injury or death may result.

2. Safety

2.2 Safety Decals

The safety decals existing on the attachment should be clearly readable and always followed.

The READ MANUAL decal warns the operator to read this manual before operating the attachment.

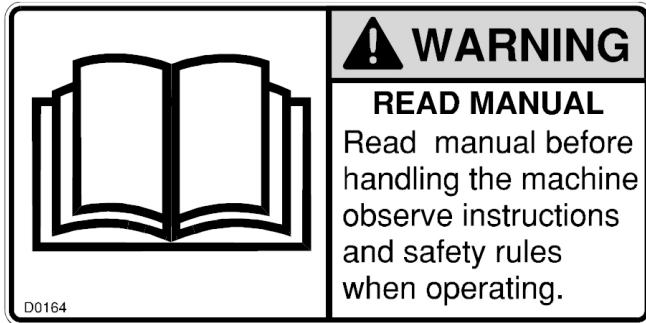

The ROTATING CUTTER decal warns the operator and bystanders to stay away during operation.

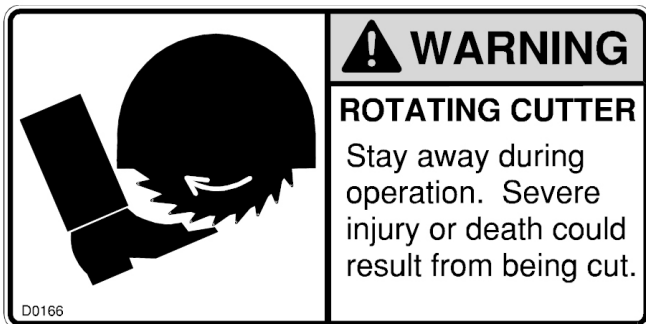

The FLYING OBJECTS decal warns the operator and bystanders to stay away during operation.



The INJECTION HAZARD decal warns the operator and bystanders to stay away during operation.

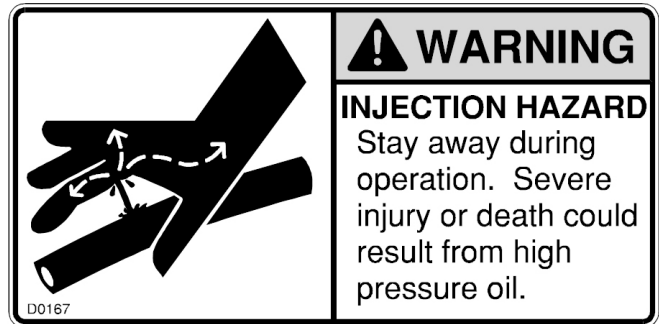

The CRUSHING HAZARD decal warns the operator and bystanders to stay away during operation.

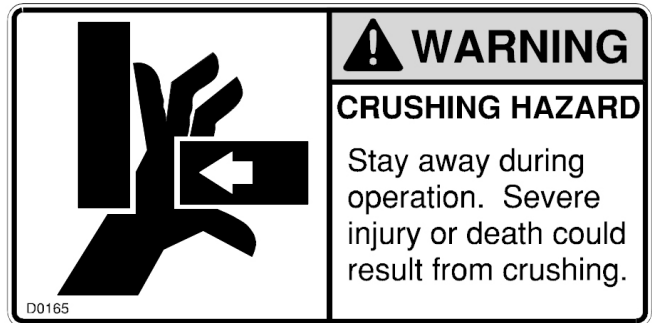

2. Safety

2.3 Safety Precautions

Before operating or conducting maintenance on this equipment, it is important to wear proper protection. Recommended safety equipment when operating and maintaining includes earplugs, eye protection, and a hard hat.

NOTE: Additional safety equipment may be required depending on the operating environment and worksite conditions.

Only qualified and trained personnel should operate, maintain, and service this attachment. Blue Diamond® recommends that you inspect this equipment regularly for leaks, cracks, or other conditions that may impair proper usage of the equipment. Verify that all repairs have been completed and inspected prior to using the attachment under load.

Accidents are Preventable

It is the responsibility of the user to follow all local, state, and federal safety regulations.

- Call local utilities before you dig.
- Know the location of underground gas, water, and electrical lines.
- Inspect area for holes, drop-offs, or unstable ground.
- Know the weight limitations of operating surfaces and clearances.
- Remember: Safe operation begins with the operator!

Improper use of this equipment may result in personal injury, property damage, and/or damage to the equipment.

2.4 Mandatory Shutdown Procedure



WARNING



Before operating this equipment, the following safety information should be read and understood. In addition, each individual working with the equipment should be familiar with the safety precautions.



WARNING



Failure to follow the procedures before cleaning, adjusting, lubricating, or servicing this unit could lead to serious injury or death.

BEFORE cleaning, adjusting, lubricating, or servicing this unit, ALWAYS follow the MANDATORY SAFETY SHUTDOWN PROCEDURE:

1. Move the skid steer loader propulsion control levers to the neutral position.
2. Shut off the attachment by shutting off the auxiliary and high flow hydraulic output.
3. Lower the loader lift arms completely and roll the attachment forward so it is securely resting on firm ground or the shop floor.
4. Engage the loader parking brake.
5. Move the loader throttle to the slow idle position, shut the engine off, and remove the ignition key.
6. Keep the key with you at all times when working on the unit so no one can start the engine without your knowledge.

3. Setup



WARNING



Read this entire manual as well as the decals on the attachment before attempting any maintenance, service, or setup of the unit.

Although the Blue Diamond® Cold Planer is supplied fully assembled, some simple checks should be performed before operation begins.

Safety Decals

The safety decals existing on the attachment should be clearly readable always followed. The descriptions of the decals are shown in the “Safety Decals” section 2.2 on page 6.

Hydraulic Couplers

The cold planer may have been shipped without the required hydraulic quick couplers. Obtain correct brand and size and install them on the hoses.

On a 3 lines planer, the pressure “in” port on the diverter valve is marked LP for motor pressure. Return flow to the loader is marked LR for motor return. The small hose is for drive motor case drain and is plumbed directly to the skid steer case drain coupler.

The case drain hose should be connected directly to the case drain coupler on the skid steer. Do not operate without connecting this hose.

Hoses/Fittings

Hydraulic fittings are used to connect all attachment hoses. All fittings should be tight and free of hydraulic leaks. Hoses must be free of crimps or cuts that might result in leakage. Check your attachment before operation to make sure all hose routings are kink-free and allow for maximum movement of all extend, lift/lower, and/or swing motion required during normal operation.

Wire Harness

The wiring harness to the electro hydraulic valve block should be routed to prevent catching or pinching when side shifting, tilting, or lowering the drum fully into the cut.

Drum Assembly

For proper operation, picks must be installed in every holder on the drum.

3. Setup

Drum Assembly



WARNING



Unobstructed case drain flow is critical to proper planer motor operation. Blocked case drain flow will damage the planer motor.

The Blue Diamond® high flow cold planer has a planetary gearbox mounted within the drum which is driven through a hydraulic piston motor.

During motor operation, some oil bypasses the motor and must be allowed an unobstructed path back to the hydraulic tank. If this flow is restricted, then pressure will build up inside the motor and will fail the motor's shaft seal or the end cap gasket, or both.

Several causes can lead to this failure:

1. Pinched or crushed case drain hose can restrict flow.
2. Disconnected case drain quick coupler can restrict flow.
3. Drum teeth come in contact with the pavement or trailer ramps while the skid steer is in motion, forcing the drum to rotate with the high flow hydraulic circuit "off." This drum rotation forces the motor to turn, which pressurizes the motor's case, because the pressure and return oil's path has been blocked.

If the above issues are not addressed, severe motor damage may result. All of these issues can be attributed to the operator and are preventable with proper operation. Different manufacturers of skid steers use different sizes of case drain couplers and locate the coupler on the skid steer in a different location. Never switch planer between skid steer manufacturers without ensuring the case drain line is hooked up to the correct coupler.

Unless a defect in the motor is found, these shaft seal and end cap gasket failures are not covered under warranty.

4. Operation

4.1 Attaching to Loader

To attach the unit to the loader, start the loader engine and rotate the coupler out. Pull both coupler levers up to the vertical position. Move the machine forward and pick up the attachment. Rotate the attachment back and push both coupler levers completely down. Make sure the two wedges are completely down and engaged. Be sure pins and latch handles are secure before operating boom and bucket. **Always refer to operating instructions in the skid manual.**



All hoses should be free of kinks, cuts, or abrasions for safe operation. Do not operate if hoses are worn or damaged.

Next, connect all hydraulic hoses to the skid steer quick couplers. Three hoses must be connected: motor pressure, motor return, and motor case drain.

Lastly, connect the wiring harness to the skid steer.

4.2 Basic Operation

See the specifications in this manual for minimum and maximum pressure and flow requirements. Maximum pressures vary depending on planer valve configuration. Valve configuration varies depending on skid steer manufacturer.



Insufficient hydraulic power will result in poor performance. Check pressure and flow per factory skid steer specifications.

The cold planer is a hydraulically powered attachment intended for cutting asphalt or concrete surfaces. The performance of the attachment can vary greatly depending on how it is used and operated. The recommended operating procedures in this manual should be followed at all times for maximum productivity.

Before operating the attachment, read this entire manual. Follow all safety guidelines in this manual and safety decals on the unit. Make sure that all guards, shields, and decals are in place and in good condition prior to operation.

1. Enter skid steer and fasten seat belt.
2. Make sure the area is clear of bystanders and other workers.
3. Start the skid steer and engage the high flow hydraulic circuit at idle.
4. Adjust the planer's tilt, depth, and side shift as needed using the electro-hydraulic controls. The high flow circuit must be engaged to operate these adjustments.
5. Fully lower the loader arms and then roll out the bucket function until the planer is level with the pavement.
6. Move the throttle to the full rpm position and keep it there during the milling operations. Begin the operation by setting the depth cylinders to zero depth. Lower the drum into the cut to the desired depth. Move forward at a speed that will allow the drum to cut efficiently without stalling.

4. Operation

4.3 Maximizing Production

Production can vary greatly depending on milling depth, type of aggregate in the mix, ambient temperature, and condition of the cutting teeth.

Teeth should be inspected every 30 minutes and worn teeth replaced. Teeth should freely rotate in their holders. See the maintenance section beginning on page 12 for more information.

Optional teeth for milling concrete and water spray kits are available. Water spray kits increase production by suppressing dust and helping the teeth rotate properly.

Only cut straight lines. Do not turn while milling. Cutting curves will quickly wear the edge picks, decreasing production. Milling a radius or curve can also damage the drum.

5. Maintenance

5.1 General Maintenance



WARNING



Before performing any maintenance on the unit, perform the mandatory safety shutdown procedure.

Proper maintenance of the attachment will result in longer life and more productive and cost effective operation. There are two basic categories of maintenance: cutting drum maintenance and component lubrication.

5.2 Cutting Drum Maintenance

Cutting Drum maintenance is critical to extending the life of the pick and holder and overall production of the cold planer. Inspect the cutting drum every 30 minutes of operation.

The factory installed carbide pick is a general purpose pick and is designed for milling both asphalt and concrete. Picks designed for extended periods of concrete cutting are available from the factory or your dealer.

Pick life varies with depth, density, material, aggregate and maintenance, which includes allowing the tooth to rotate. To maximize pick life, the picks must be free to rotate in the holder. The pick has two functions: serves as the consumable cutting tool and it protects the holder. The tooth must be free to rotate in the holder. If it locks up, then tooth and holder wear is greatly accelerated.

Edge teeth wear faster than center teeth, due to side loading of the drum during the loader's steering corrections.

To promote pick rotation, spray the picks daily with a water based asphalt emulsifier to break down asphalt emulsion. (Example: Zep's part #AR6690)

If the pick remains in the holder beyond its intended replacement point, it reduces the cutting

performance and will not protect the holder. If the picks are worn enough to indicate slight holder wear, replace the picks.

Blue Diamond® recommends using a water spray kit. Using water may increase tooth life by 20 to 40% and also suppresses the milling dust.

TIP: Adding 8oz. of Dawn Dish liquid to the water tank emulsifies the asphalt on the teeth.

The pictures on page 13 show examples of excessively worn teeth.



WARNING



Never strike the pick on the carbide tip. The carbide can break or chip and cause injury.



WARNING



Always wear eye protection when performing this operation. Hardened tool and carbide picks can shatter causing injury.

Removing and Installing Teeth

A fork type pick tool is included with the cold planer and should be used to remove the picks from the holders. Insert the fork into the groove on the tool and strike the tool with a hammer. In the event the pick tool is not available, a punch may be inserted into the bottom of the holders and can be used to dislodge the pick.

For installation, the fork type tool should be inserted into the groove on the tooth and struck with a hammer. Also, if the tool is not available, a length of pipe with a 3/4 to 1 inch inside diameter can be placed over the pick to protect the carbide from a direct hit. Striking a small piece of wood placed on the pick to absorb the shock will also prevent damage.

DO NOT STRIKE THE CARBIDE TOOTH TIP WHEN INSTALLING TEETH.

5. Maintenance

EXAMPLES OF REMAINING TOOTH LIFE (%)

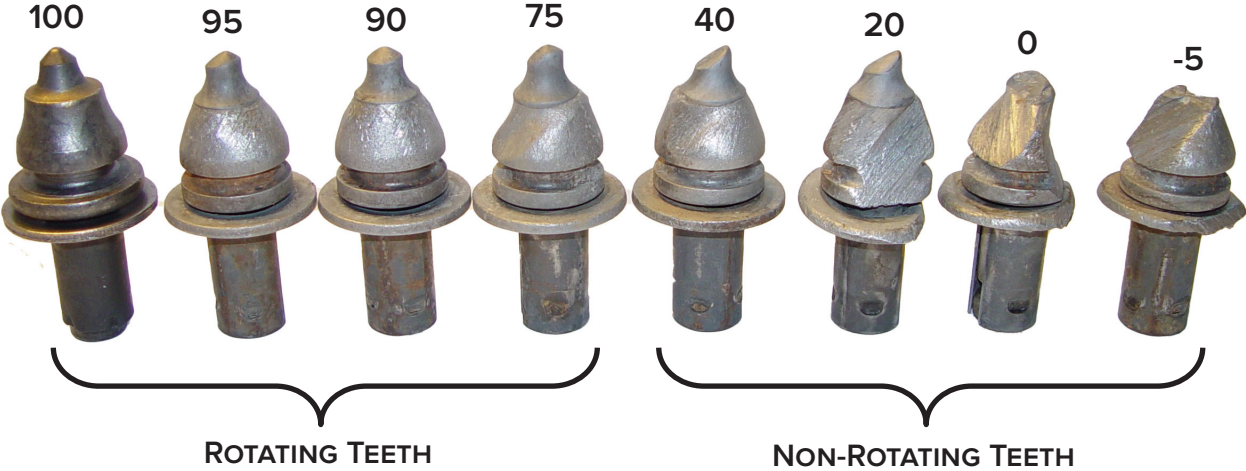

TEETH MAY LAST TWICE AS LONG IF THEY ARE FREE TO ROTATE IN THEIR HOLDER.

THE FOLLOWING PICTURE SHOWS A TOOTH EXCESSIVELY WORN AND NOT ROTATING IN THE HOLDER.

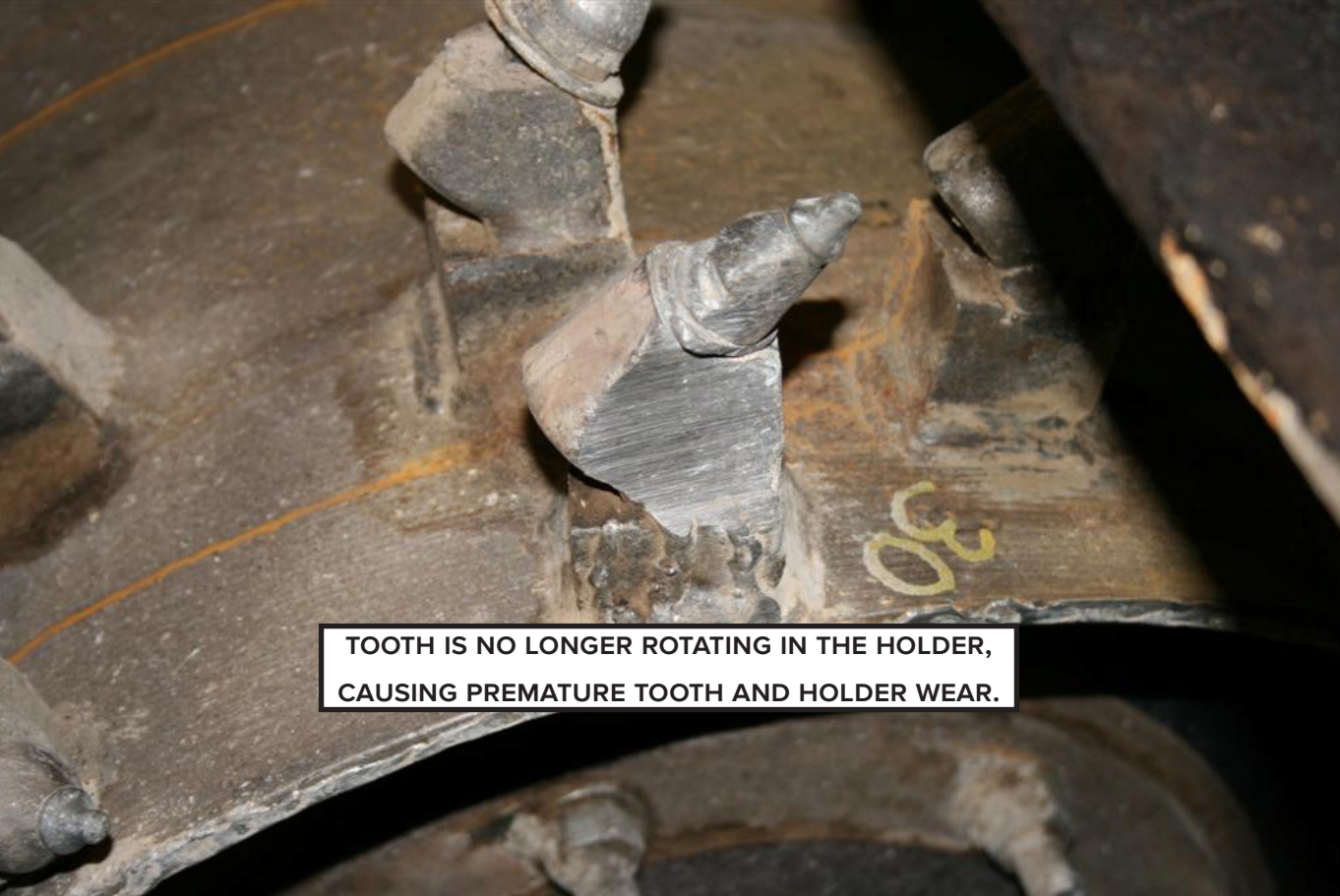

5. Maintenance

Pick Holder Repair



WARNING



To avoid bearing damage, always ground directly to the drum before welding.

If a pick holder becomes worn, note the position and angle of the holder, cut the pick holder from the drum using a torch or air-arc. Weld the new holder to the drum in the noted position.

Blue Diamond® does not warrant ANY ground engaging parts (drums, teeth, holders, or bases) against wear, unless the wear is determined by Blue Diamond® to have been caused by a manufacturing defect.

5.3 Cold Planer Lubrication



WARNING



Failure to follow the procedures before cleaning, adjusting, lubricating, or servicing this unit could lead to serious injury or death.

Always follow the Mandatory Safety Shutdown Procedure on page 7 before performing **any** maintenance.

There are three types of lubrication required on the Blue Diamond® planer. They are spray lubrication, greased components, and planetary gearbox oil.

Spray Lubrication

Spray side shift bars with graphite lube spray (such as CRC 03094) once a week. Do not apply grease to the side shift bars. Grease catches milling dust and causes the side shift mechanism to bind and wear quickly.

Spray the left and right depth skids where they are retained with graphite lube spray (such as CRC 03094) once a week. Do not apply grease to the depth skids. Grease catches milling dust and causes the side shift mechanism to bind and wear quickly.

Grease Lubrication

All greased components should be greased with an EP Lithium NLGL No. 2 grade grease. One example is Mobilux EP2.

The dead shaft bearing grease zerk can be found on the right side of the chassis. It is recessed in a hole in the chassis plate. It should be greased daily or every 8 hours of operation.

The depth cylinders have a grease zerk on each end. They are located on the sides of the cold planer. These zerks should be greased weekly or every 40 hours of operation.

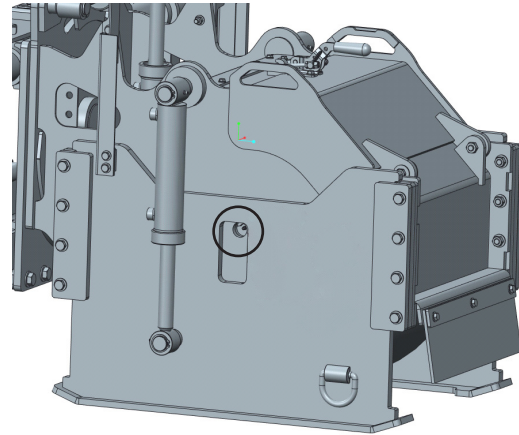

5. Maintenance

Planetary Gearbox

The planetary gearbox oil should be drained and refilled at 100 hours of operation and every 250 hours after the initial change.

The planetary gearbox contains synthetic EP90 gear oil and should be half full during operation. The planetary gear oil should be drained and replaced each year.

Oil Drain and Fill Procedure:

1. Clean area around drain holes on gearbox spindle.
2. Remove drain plugs on gearbox spindle. Rotate drum so a drain plug is on the bottom. Drain oil.
3. Rotate gearbox so one is plug is horizontal and the other is at the top.
4. Slowly fill gearbox through top spindle drain hole until oil fill reaches the horizontal spindle drain hole.
5. The gearbox should be half full of AGMA EP90 synthetic gear lubricant or SAE 75W90 synthetic gear lubricant. (Chevron RPM Synthetic 75W90 for example) The approximate volume of the gearbox and input adapter is approximately 30 oz.
6. Replace gearbox spindle plug.

5.4 Drum Removal



WARNING



Exercise extreme caution during this operation to prevent tipping of the unit.



WARNING



Components are extremely heavy and can cause serious injury if proper lifting techniques are not used.

1. Perform mandatory shutdown procedure with the cold planer adjusted to the maximum depth. Ensure that planer drum is sitting on a stable surface and is chocked to prevent movement.

2. Disconnect the pressure, return, and case drain hose from the hydraulic motor.
3. Remove two (2) motor bolts and lift motor away from chassis.
4. Remove two (2) retaining rings on each depth cylinder. Remove depth cylinders and set aside.
5. Remove the eight (8) bolts retaining each depth skid to the chassis. Remove depth skids and set aside.
6. Remove the eight (8) bolts holding the planetary gearbox to the chassis on the left side.
7. Remove (4) bolts holding the bearing to the chassis on the right side.
8. Lift chassis off drum assembly.

5.5 Planetary Gearbox Removal



WARNING



If the drum does not remain on the floor, lower the planer chassis and shut the engine off. Check alignment of bearing, gearbox, and drum to chassis. Do not attempt to dislodge the drum while the planer frame is in the raised position. Never place hands or any part of your body in, around, or under the drum, as it may fall and cause serious injury.

1. Remove the drum from the planer chassis.
2. Remove six (6) dead shaft nuts from the right side of the drum and remove the dead shaft weldment.
3. Remove nine (9) planetary stud nuts from the **right** side of the drum.
4. Remove Planetary / Planetary assembly from the **left** side of drum.

6. Diagrams & Parts

6.1 Chassis Parts: 18" & 24" Models

160225-HP, 160230-HP, 160810-HP, and 160815-HP

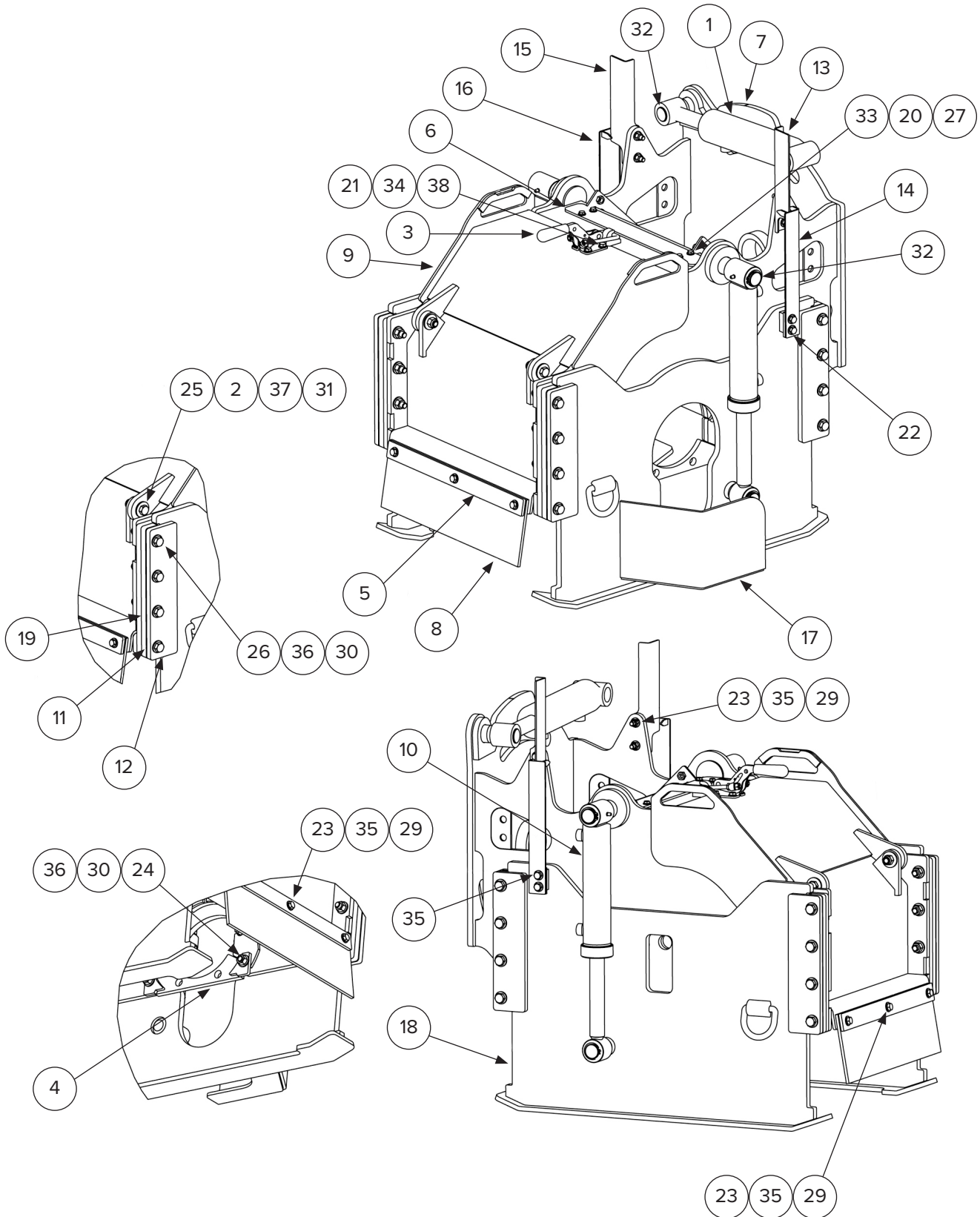

6. Diagrams & Parts

ITEM NO.	PARTS DESCRIPTION	18" 160225-HP	24" 160230-HP	18" SEVERE DUTY 160810-HP	24" SEVERE DUTY 160815-HP	QTY
1	Cylinder, Tilt (Seal Kit: 216143)	216230	216230	216230	216230	1
2	Cold Planer Shroud Bolt Bushing	260201	260201	260201	260201	2
3	Latch Assembly, Draw	260040	260040	260040	260040	1
4	Weldment, Planetary Support	260115	260115	260115	260115	1
5	Plate, Belting Retainer	260372	260371	260372	260371	2
6	Plate, Water Spray Bar Cover	260383	260380	260383	260380	1
7	Chassis Weldment	260330	260329	260205	260213	1
8	Belting, Rubber	260015	260016	260015	260016	2
9	Weldment, Chassis Shroud	260339	260337	260206	260214	1
10	Cylinder, Depth (Seal Kit: Note A)	260051	260051	260056	260056	2
11	Plate, Depth Guide Inner	260389	260389	260389	260389	4
12	Plate, Depth Guide Outer	260384	260384	260384	260384	4
13	Plate, Depth Gage Left	260055	260055	260207	260207	1
14	Weldment, Depth Gage Left	260370	260370	260208	260208	1
15	Plate, Depth Gage Right	260054	260054	260209	260209	1
16	Weldment, Depth Gage Right	260374	260374	260210	260210	1
17	Cold Planer Left Depth Skid Weldment	260202	260202	260211	260211	1
18	Cold Planer Right Depth Skid Weldment	260203	260203	260212	260212	1
19	Cold Planer Depth Skid Spacer Plate	260204	260204	260204	260204	4
20	Bolt, 1/4-20 X 1.00 Plated	216403	216403	216403	216403	4
21	Bolt, 5/16-18 X 1.00 Plated	299317	299317	299317	299317	4
22	Bolt, 3/8-16 X 0.75 Plated	299424	299424	299424	299424	4
23	Bolt, 3/8-16 X 1.50 Plated	216465-1	216465-1	216465-1	216465-1	10
24	Bolt, 1/2-13 X 1.75 Plated	216491	216491	216491	216491	2
25	Bolt, 1/2-13 X 2.00 Plated	299433	299433	299433	299433	2
26	1/2-13 X 3 1/4" Bolt Hex Head Grade 8 Zinc Yellow Chromate Plated	299483	299483	299483	299483	16
27	Nut, 1/4-20 Plated Nylock	299615	299615	299615	299615	4
28	Nut, 5/16-18 Plated Nylock	216546	216546	216546	216546	4
29	Nut, 3/8-16 Plated Nylock	216447	216447	216447	216447	10
30	Nut, 1/2-13 Plated	299574	299574	299574	299574	18
31	Nut, 1/2-20 Plated Nylock	216490	216490	216490	216490	2
32	Retaining Ring, External 1.25" Dia.	260029	260029	260029	260029	5
33	Washer, 1/4 Narrow Plated	216405	216405	216405	216405	8
34	Washer, 5/16 Narrow Plated	216547	216547	216547	216547	8
35	Washer, 3/8 Narrow Plated	216446	216446	216446	216446	24
36	Washer, 1/2 Narrow Plated	216427	216427	216427	216427	36
37	Washer, 1/2 Wide Plated	299730	299730	299730	299730	4

NOTE A: 260051 Seal Kit 260057; 260056 Seal Kit 260058.

6. Diagrams & Parts

6.2 Chassis Parts: 30", 40", & 48" Models

160235-HP, 160820-HP, 160240-HP, 160825-HP, 160245-HP, and 160830-HP

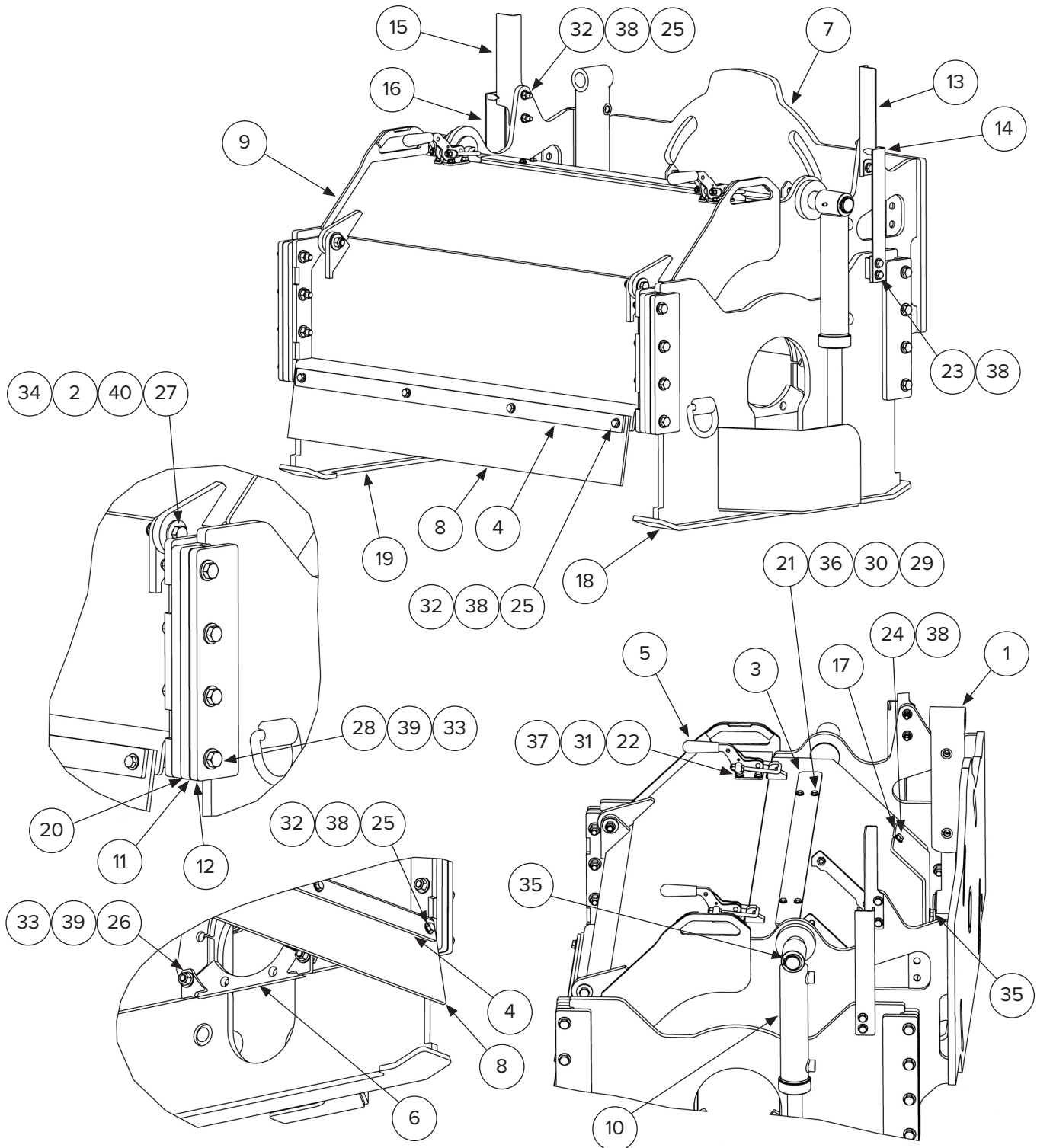

ITEM NO.	PARTS DESCRIPTION	30" 160230-HP	40" 160240-HP	48" 160245-HP	Severe Duty 30" 160820-HP	Severe Duty 40" 160825-HP	Severe Duty 48" 160830-HP	QTY
1	Cylinder, Tilt (Seal Kit: 216143)	216230	216230	216230	216230	216230	216230	1
2	Shroud Bolt Bushing	260201	260201	260201	260201	260201	260201	2
3	Plate, Waterkit Cover	260366	260367	260225	260366	260367	260225	1

6. Diagrams & Parts

ITEM NO.	PARTS DESCRIPTION	30" 160235-HP	40" 160240-HP	48" 160245-HP	30" SEVERE DUTY 160820-HP	40" SEVERE DUTY 160825-HP	48" SEVERE DUTY 160830-HP	QTY
4	Plate, Belting Retainer	260364	260363	260215	260364	260363	260215	2
5	Latch Assembly, Draw (QTY: Note B)	260040	260040	260040	260040	260040	260040	2
6	Weldment, Planetary Support	260115	260115	260115	260115	260115	260115	1
7	Chassis Weldment	260328	260327	260216	260219	260223	260221	1
8	Belting, Rubber	260362	260017	260217	260362	260017	260217	2
9	Weldment, Chassis Shroud	260335	260334	260218	260220	260224	260222	1
10	Cylinder, Depth (Seal Kit: Note A)	260051	260051	260051	260056	260056	260056	2
11	Plate, Depth Guide Inner	260389	260389	260389	260389	260389	260389	4
12	Plate, Depth Guide Outer	260384	260384	260384	260384	260384	260384	4
13	Plate, Depth Gage Left	260055	260055	260055	260207	260207	260207	1
14	Weldment, Depth Gage Left	260370	260370	260370	260208	260208	260208	1
15	Plate, Depth Gage Right	260054	260054	260054	260209	260209	260209	1
16	Weldment, Depth Gage Right	260374	260374	260374	260210	260210	260210	1
17	Plate, Tilt Pin Cover	260402	260402	260402	260402	260402	260402	1
18	Left Depth Skid Weldment	260202	260202	260202	260211	260211	260211	1
19	Right Depth Skid Weldment	260203	260203	260203	260212	260212	260212	1
20	Depth Skid Spacer Plate	260204	260204	260204	260204	260204	260204	4
21	Bolt, 1/4-20 X 1.00 Plated	216403	216403	216403	216403	216403	216403	4
22	Bolt, 5/16-18 X 1.00 Plated	299317	299317	299317	299317	299317	299317	8
23	Bolt, 3/8-16 X 0.75 Plated	299424	299424	299424	299424	299424	299424	4
24	Bolt, 3/8-16 X 1.00 Plated	299423	299423	299423	299423	299423	299423	3
25	Bolt, 3/8-16 X 1.50 Plated	216465-1	216465-1	216465-1	216465-1	216465-1	216465-1	12
26	Bolt, 1/2-13 X 1.75 Plated	216491	216491	216491	216491	216491	216491	2
27	Bolt, 1/2-13 X 2.00 Plated	299433	299433	299433	299433	299433	299433	2
28	1/2-13 X 3 1/4" Bolt Hex Head Grade 8 Zinc Yellow Chromate Plated	299483	299483	299483	299483	299483	299483	16
29	Nut, 1/4-20 Plated	216404	216404	216404	216404	216404	216404	2
30	Nut, 1/4-20 Plated Nylock	299615	299615	299615	299615	299615	299615	2
31	Nut, 5/16-18 Plated Nylock	216546	216546	216546	216546	216546	216546	8
32	Nut, 3/8-16 Plated Nylock	216447	216447	216447	216447	216447	216447	12
33	Nut, 1/2-13 Plated	299574	299574	299574	299574	299574	299574	18
34	Nut, 1/2-20 Plated Nylock	216490	216490	216490	216490	216490	216490	2
35	Retaining Ring, External 1.25" Dia.	260029	260029	260029	260029	260029	260029	5
36	Washer, 1/4 Narrow Plated	216405	216405	216405	216405	216405	216405	8
37	Washer, 5/16 Narrow Plated	216547	216547	216547	216547	216547	216547	16
38	Washer, 3/8 Narrow Plated	216446	216446	216446	216446	216446	216446	31
39	Washer, 1/2 Narrow Plated	216427	216427	216427	216427	216427	216427	36
40	Washer, 1/2 Wide Plated	299730	299730	299730	299730	299730	299730	4

NOTE A: 260051 Seal Kit 260057; 260056 Seal Kit 260058

NOTE B: 160825-HP and 160830-HP use 3 latches instead of 2.

6. Diagrams & Parts

6.3 Drivetrain Parts

160225-HP, 160230-HP, 160235-HP, 160240-HP, and 160245-HP

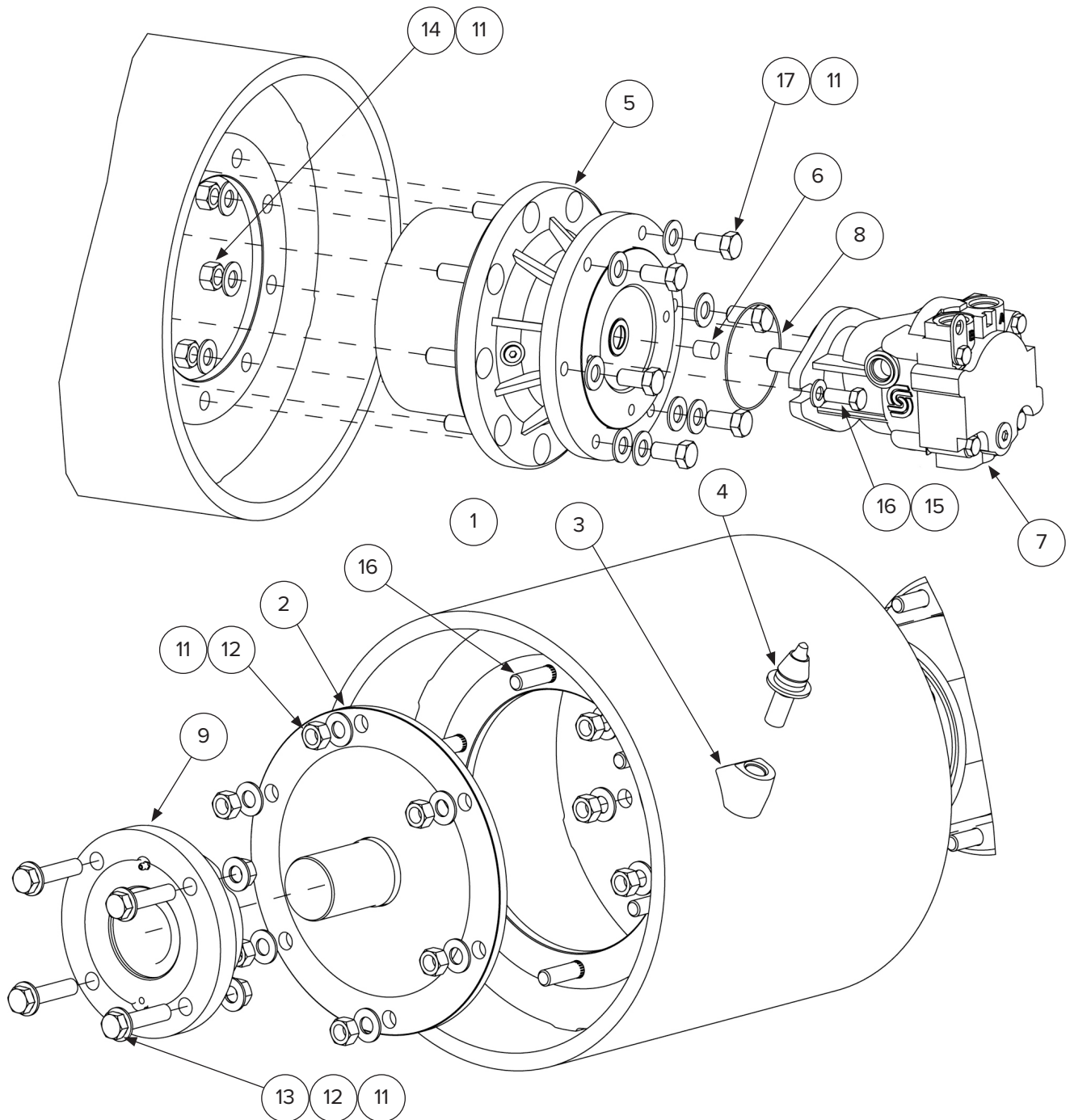

6. Diagrams & Parts

ITEM NO.	PARTS DESCRIPTION	18" 160225-HP	24" 160230-HP	30" 160235-HP	40" 160240-HP	48" 160245-HP	QTY
1	Assembly, Drum Picks & Studs	260826	260828	260324	260323	260226	1
2	Bolt, 5/8-11 X 2.25 Round Hd, Ribbed Neck	260172	260172	260172	260172	260172	6
3	Holder, Pick	260003	260003	260003	260003	260003	NOTE A
4	Pick, Asphalt (Concrete Pick: 260004)	260001	260001	260001	260001	260001	
5	Gearbox, Planetary (Note B) (Note D)	260110	260110	260110	260110	260110	1
6	Spacer, Gearbox Disconnect	260390	260390	260390	260390	260390	1
7	Motor, Hyd Piston (Note B) (Note C) (Note D)	260010	260010	260010	260010	260010	1
8	Seal, O-Ring 2-045	260030	260030	260030	260030	260030	1
9	Bearing Assembly, Dead Shaft	260105	260105	260105	260105	260105	1
10	Weldment, Machined Dead Shaft	260100	260100	260100	260100	260100	1
11	Washer, 5/8 Narrow Plated	299844	299844	299844	299844	299844	31
12	Nut, 5/8-11 Plated	299575	299575	299575	299575	299575	10
13	Bolt, 5/8-11 X 2.75 Plated	299459	299459	299459	299459	299459	4
14	Nut, 5/8-18 Plated	299585	299585	299585	299585	299585	9
15	Washer, 1/2 Narrow Plated	216427	216427	216427	216427	216427	2
16	Bolt, 1/2-20 X 1.25 Plated	299463	299463	299463	299463	299463	2
17	Bolt, 5/8-11 X 1.25 Plated (Note D)	299484	299484	299484	299484	299484	6

NOTE A: Items 3 & 4 vary in quantity as follows:

- 160225-HP — 46**
- 160230-HP — 56**
- 160235-HP — 66**
- 160240-HP — 82**
- 160245-HP — 94**

NOTE B: For repair instructions, 5 consult factory. For planers built prior to January 24, 2019: gearbox is not serviceable and must be replaced by 260110.

NOTE C: Partial Motor Parts List:

- Motor Seal Kit: 260035**
- End Plate Gasket: 260011**
- Shaft Seal: 260034**
- Shaft Seal Washer: 260024**
- Shaft Seal Retaining Ring: 260032**

NOTE D: For units equipped with 260110 Gearbox, bolt length (item 17) is critical. Bolts cannot be longer than specified or gearbox seal will be damaged. Note that the two bottom bolts have two washers each.

NOTE E: Unauthorized disassembly of these components during the warranty period may void your warranty. Consult Blue Diamond® before disassembly and repair.

6. Diagrams & Parts

6.4 Drivetrain Parts for Severe Duty Models

160810-HP, 160815-HP, 160820-HP, 160825-HP, and 160830-HP

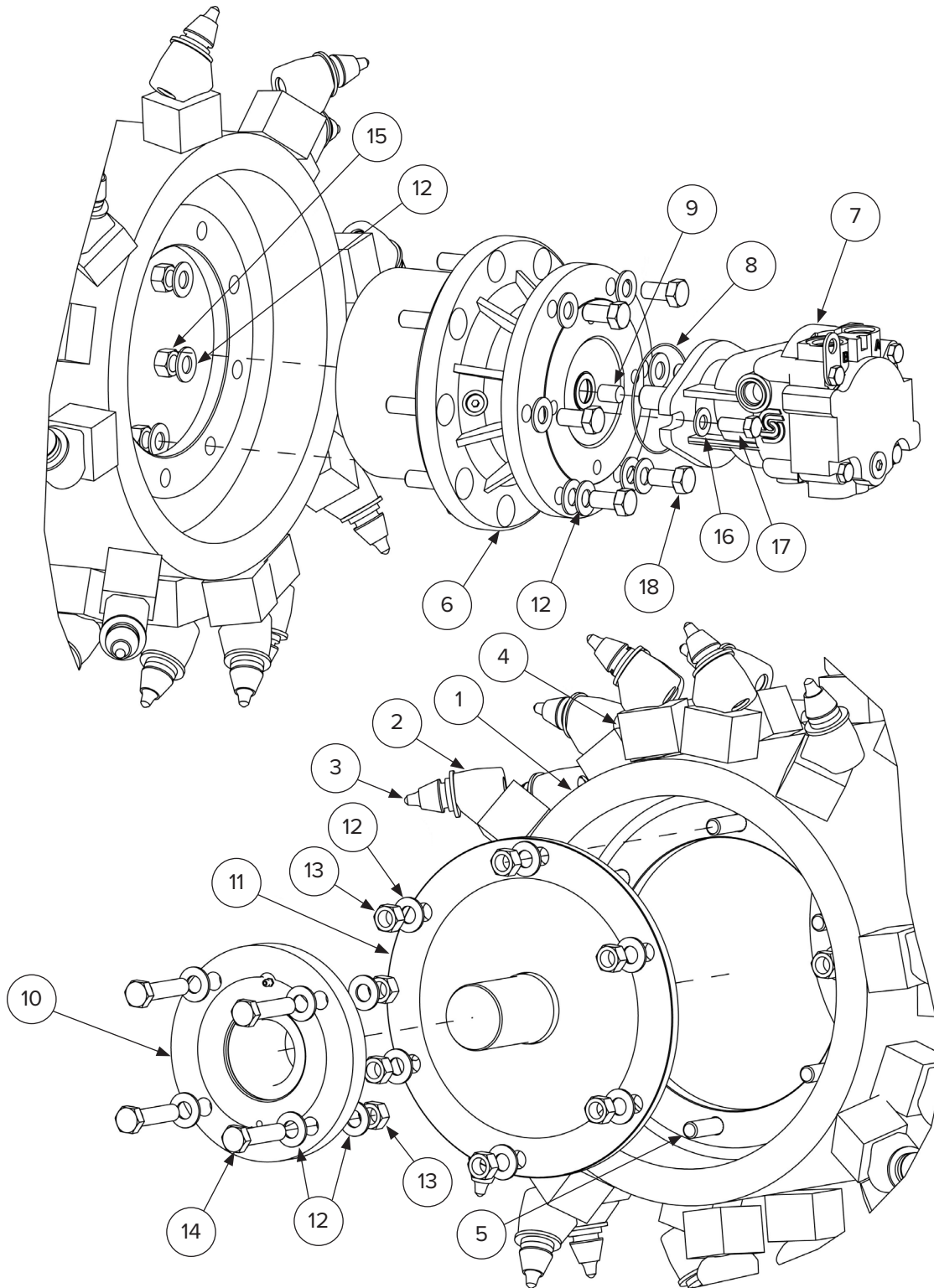

6. Diagrams & Parts

ITEM NO.	PARTS DESCRIPTION	18" SEVERE DUTY 160810-HP	24" SEVERE DUTY 160815-HP	30" SEVERE DUTY 160820-HP	40" SEVERE DUTY 160825-HP	48" SEVERE DUTY 160830-HP	QTY
1	Severe Duty Assembly Drum With Picks And Studs	260227	260228	260229	260230	260231	1
2	Holder, Pick	260003	260003	260003	260003	260003	NOTE A
3	Pick, Asphalt (Concrete Pick: 260004)	260001	260001	260001	260001	260001	
4	Severe Duty Drum Pick Holder Block						
5	Bolt, 5/8-11 X 2.25 Round Hd, Ribbed Neck	260172	260172	260172	260172	260172	6
6	Gearbox, Planetary (Note B) (Note D)	260110	260110	260110	260110	260110	1
7	Motor, Hyd Piston (Note B) (Note C) (Note D)	260010	260010	260010	260010	260010	1
8	Seal, O-Ring 2-045	260030	260030	260030	260030	260030	1
9	Spacer, Gearbox Disconnect	260390	260390	260390	260390	260390	1
10	Bearing Assembly, Dead Shaft	260105	260105	260105	260105	260105	1
11	Weldment, Machined Dead Shaft	260100	260100	260100	260100	260100	1
12	Washer, 5/8 Narrow Plated	299844	299844	299844	299844	299844	31
13	Nut, 5/8-11 Plated	299575	299575	299575	299575	299575	10
14	Bolt, 5/8-11 X 2.75 Plated	299459	299459	299459	299459	299459	4
15	Nut, 5/8-18 Plated	299585	299585	299585	299585	299585	9
16	Washer, 1/2 Narrow Plated	216427	216427	216427	216427	216427	2
17	Bolt, 1/2-20 X 1.25 Plated	299463	299463	299463	299463	299463	2
18	Bolt, 5/8-11 X 1.25 Plated (Note D)	299484	299484	299484	299484	299484	6

NOTE A: Items 2 & 3 vary in quantity as follows:

- 160810-HP — 46**
- 160815-HP — 56**
- 160820-HP — 66**
- 160825-HP — 82**
- 160830-HP — 94**

NOTE B: Consult factory for repair instructions.

NOTE C: Partial Motor Parts List:

- Motor Seal Kit: 260035**
- End Plate Gasket: 260011**
- Shaft Seal: 260034**
- Shaft Seal Washer: 260024**
- Shaft Seal Retaining Ring: 260032**

NOTE D: Bolt length (item 17) is critical. Bolts cannot be longer than specified or gearbox seal will be damaged. Note that the two bottom bolts have two washers each.

NOTE E: Unauthorized disassembly of these components during the warranty period may void your warranty. Consult Blue Diamond® before disassembly and repair.

6. Diagrams & Parts

6.5 Attach Parts for 18" & 24" Models

160225-HP, 160810-HP, 160230-HP, and 160815-HP

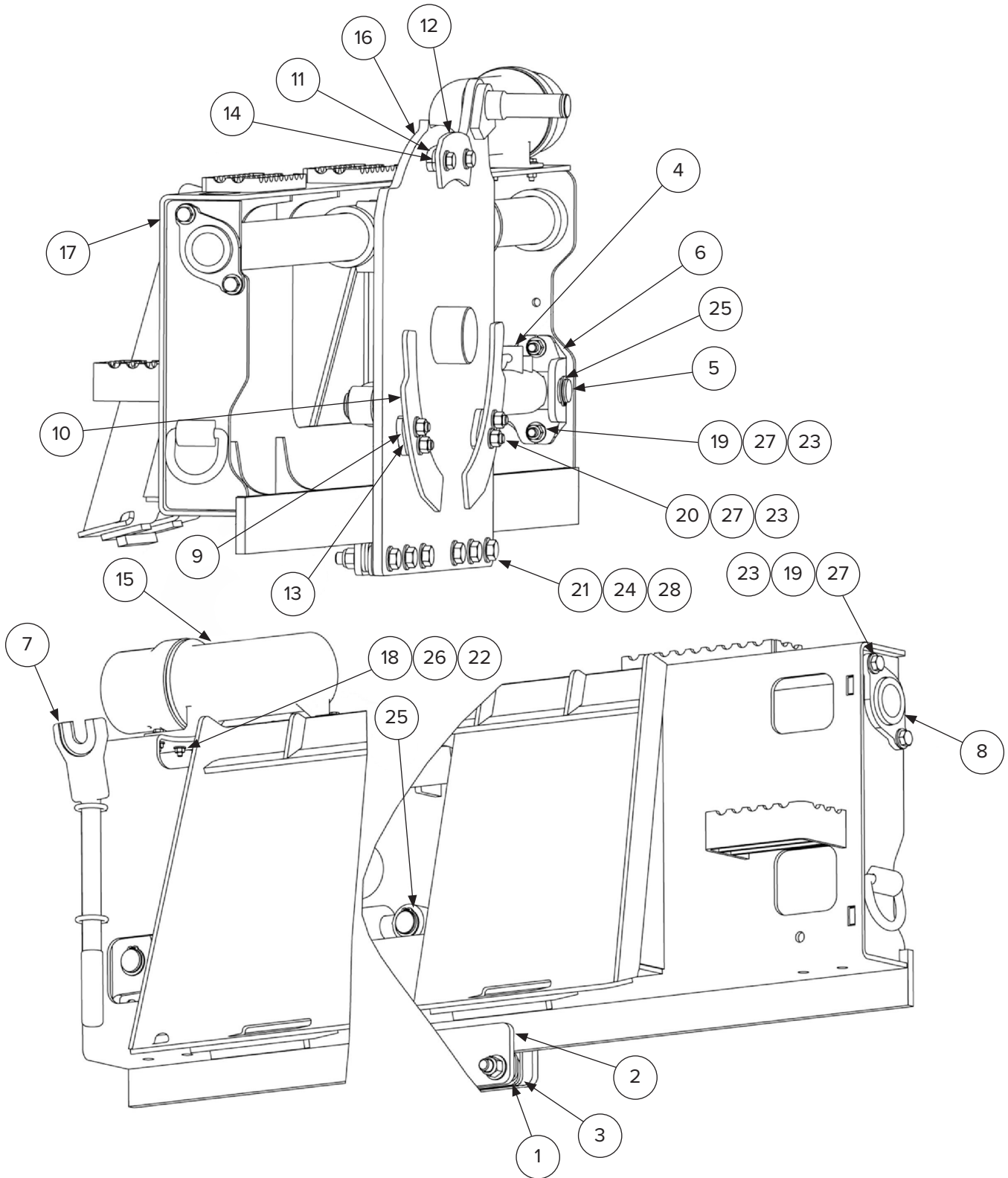

6. Diagrams & Parts

ITEM NO.	PARTS DESCRIPTION	18" 160225-HP	18" SEVERE DUTY 160810-HP	24" 160230-HP	24" SEVERE DUTY 160815-HP	QTY
1	Plate, Side Shift Spacer	260062		260062		6
2	Plate, Side Shift Retainer	260063		260063		2
3	Plate, Side Shift Spacer (Plastic)	260067		260067		2
4	Cylinder, Side Shift (Seal Kit: NOTE A)	260022		260022		1
5	Pin, Side Shift	260307		260307		1
6	Plate, Cylinder Bracket	260365		260365		1
7	Tool, Pick Removal	260070		260070		1
8	Weldment, Side Shift Rod	260020		260020		1
9	Plate, Pivot Spacer	260395		260395		2
10	Plate, Pivot Retainer Bottom Left And Right	260392		260392		2
11	Plate, Pivot Spacer	260396		260396		1
12	Plate, Pivot Retainer Top	260388		260388		1
13	Plate, Pivot Spacer	260397		260397		2
14	Plate, Pivot Spacer	260398		260398		1
15	Tube, Manual Storage	260075		260075		1
16	Weldment, Side Shift	260338		260232		1
17	Weldment, Attach	260325		260325		1
18	Bolt, 1/4-20 X 1.00 Plated	216403		216403		3
19	Bolt, 1/2-13 X 1.75 Plated	216491		216491		4
20	Bolt, 1/2-13 X 2.25 Plated	299433		299433		6
21	Bolt, 5/8-11 X 3.00 Plated	299449		299449		6
22	Nut, 1/4-20 Plated	216404		216404		3
23	Nut, 1/2-13 Plated	299574		299574		10
24	Nut, 5/8-11 Plated Nylock	299627		299627		6
25	Retaining Ring, External 1.25" Dia.	260029		260029		3
26	Washer, 1/4 Narrow Plated	216405		216405		6
27	Washer, 1/2 Narrow Plated	216427		216427		20
28	Washer, 5/8 Narrow Plated	299844		299844		12

NOTE A: Earlier units use 260023; later units use 260026. Consult Blue Diamond® Product Support.

6. Diagrams & Parts

6.6 Attach Parts for 30", 40", & 48" Models

160225-HP, 160810-HP, 160230-HP, and 160815-HP

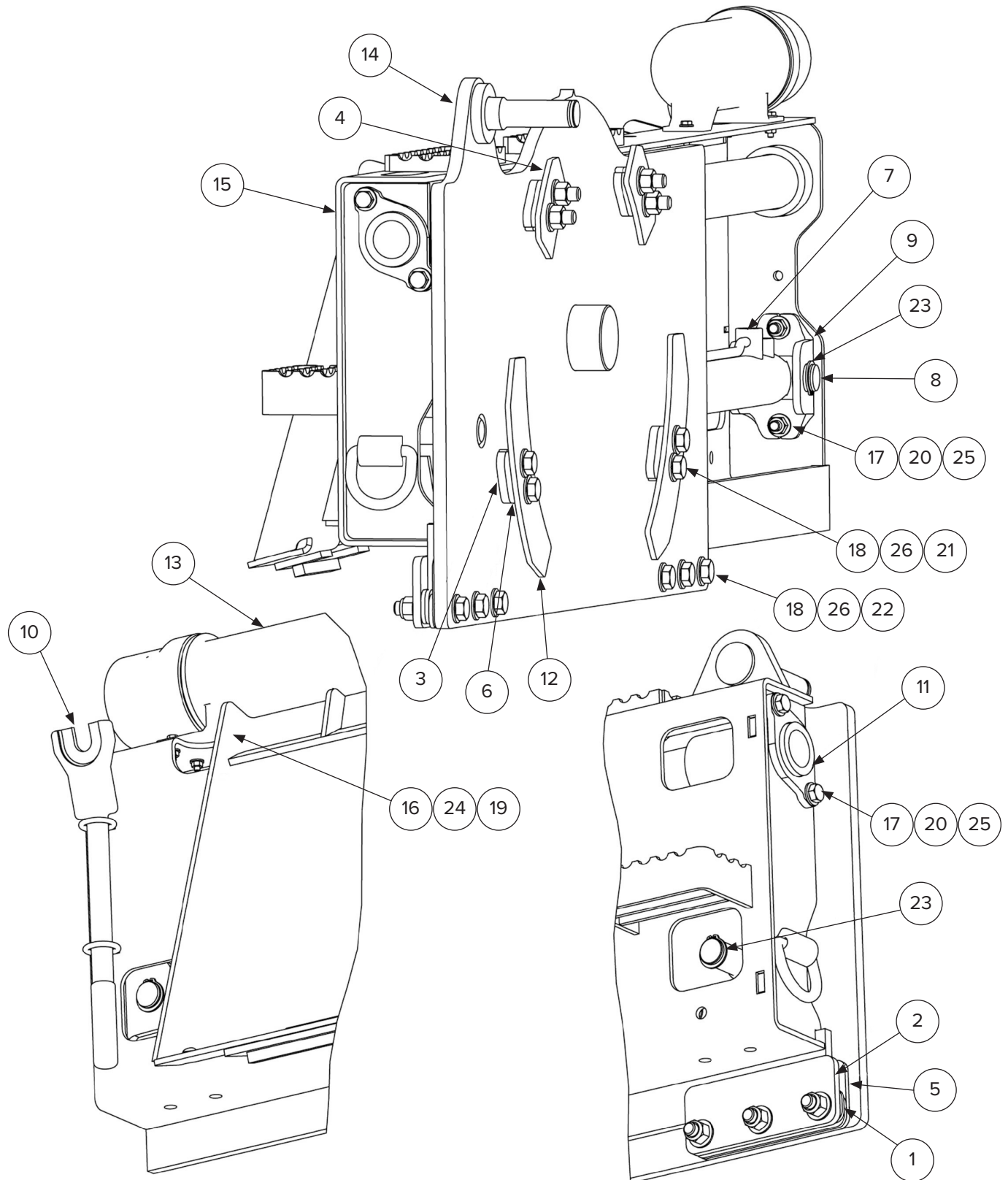

6. Diagrams & Parts

ITEM NO.	PARTS DESCRIPTION	30" 160235-HP	30" SEVERE DUTY 160820-HP	40" 160240-HP	70" SEVERE DUTY 160825-HP	48" 160245-HP	48" SEVERE DUTY 160830-HP	QTY
1	Plate, Side Shift Spacer	260062		260062		260062		6
2	Plate, Side Shift Retainer	260063		260063		260063		2
3	Plate, Pivot Spacer	260064		260064		260064		4
4	Plate, Pivot Retainer Top Left & Right	260061		260061		260061		2
5	Plate, Side Shift Spacer (Plastic)	260067		260067		260067		2
6	Plate, Pivot Spacer	260068		260068		260068		4
7	Cylinder, Sideshift (Seal Kit: NOTE A)	260022		260022		260022		1
8	Pin, Side Shift/LF Jack	260307		260307		260307		1
9	Plate, Cylinder Bracket	260365		260365		260365		1
10	Tool, Pick Removal	260070		260070		260070		1
11	Weldment, Side Shift Rod	260020		260020		260020		1
12	Plate, Pivot Retainer	260060		260060		260060		2
13	Tube, Manual Storage	260075		260075		260075		1
14	Weldment, Side Shift	260025		260025		260025		1
15	Weldment, Attach	260071		260071		260071		1
16	Bolt, 1/4-20 X 1.00 Plated	216403		216403		216403		3
17	Bolt, 1/2-13 X 1.75 Plated	216491		216491		216491		4
18	Bolt, 5/8-11 X 3.00 Plated	299449		299449		299449		14
19	Nut, 1/4-20 Plated	216404		216404		216404		3
20	Nut, 1/2-13 Plated	299574		299574		299574		4
21	Nut, 5/8-11 Plated	299575		299575		299575		8
22	Nut, 5/8-11 Plated Nylock	299627		299627		299627		6
23	Retaining Ring-External 1,25" Dia.	260029		260029		260029		3
24	Washer, 1/4 Narrow Plated	216405		216405		216405		6
25	Washer, 1/2 Narrow Plated	216427		216427		216427		8
26	Washer, 5/8 Narrow Plated	299844		299844		299844		28

NOTE A: Earlier units use 260023; later units use 260026. Consult Blue Diamond® Product Support.

6. Diagrams & Parts

6.7 Decal Locations

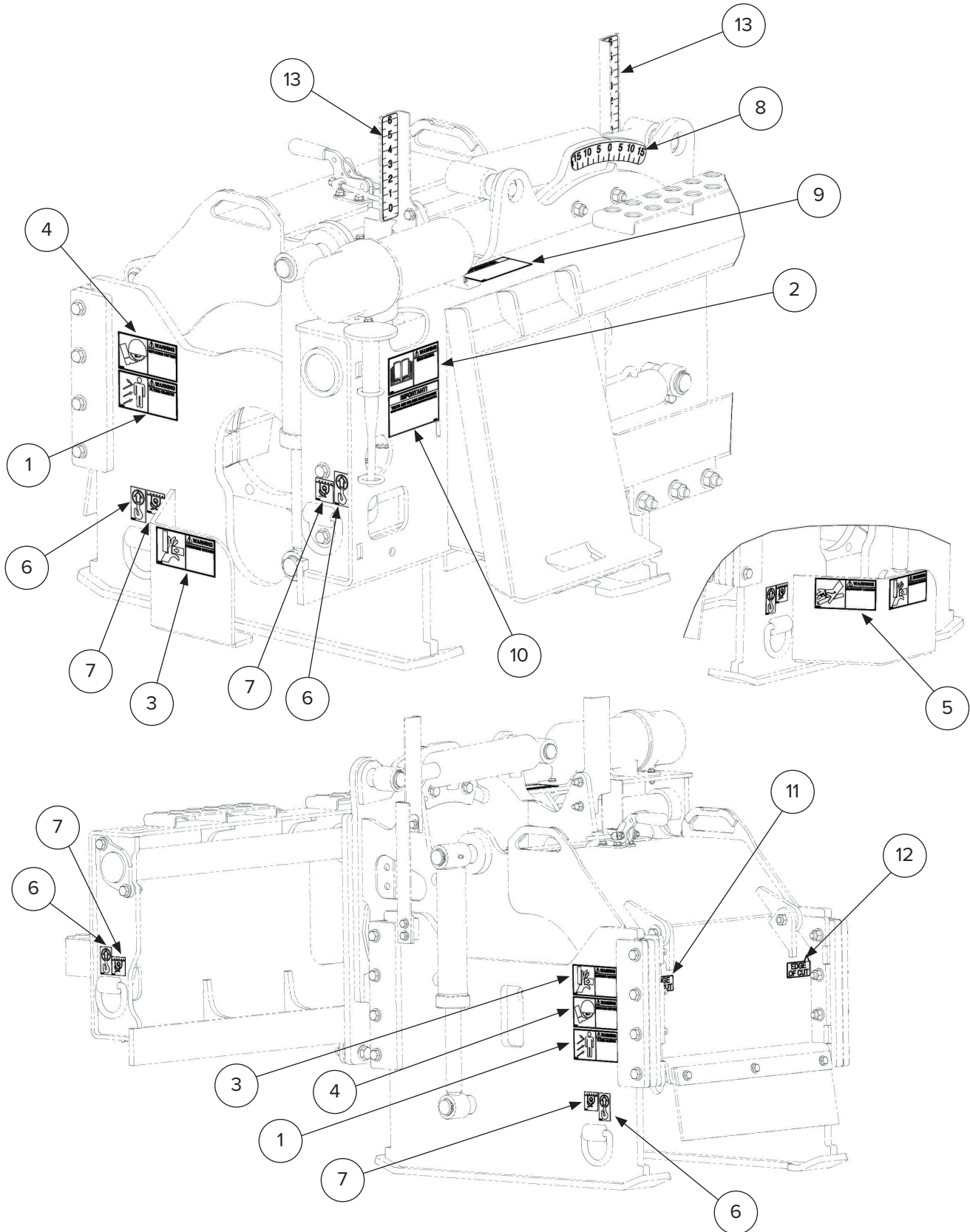

6. Diagrams & Parts

ITEM NO.	DECAL DESCRIPTION	COLD PLANER ALL WIDTHS	SEVERE DUTY COLD PLANER ALL WIDTHS	QTY
1	Flying Object	260050		2
2	Read Manual	260178		1
3	Crushing Hazard	260179		2
4	Rotating Cutter	260180		2
5	Injection Hazard	260181		1
6	Lift Point	260182		4
7	Tie Down	260183		4
8	Tilt Indicator	260184		1
9	Case Drain Information	260379		1
10	Tooth Maintenance	260185		1
11	Edge of Cut (Right)	260385		1
12	Edge of Cut (Left)	260386		1
13	Depth Indicator	260050	260234	2

6. Diagrams & Parts

6.8 Hydraulic Parts

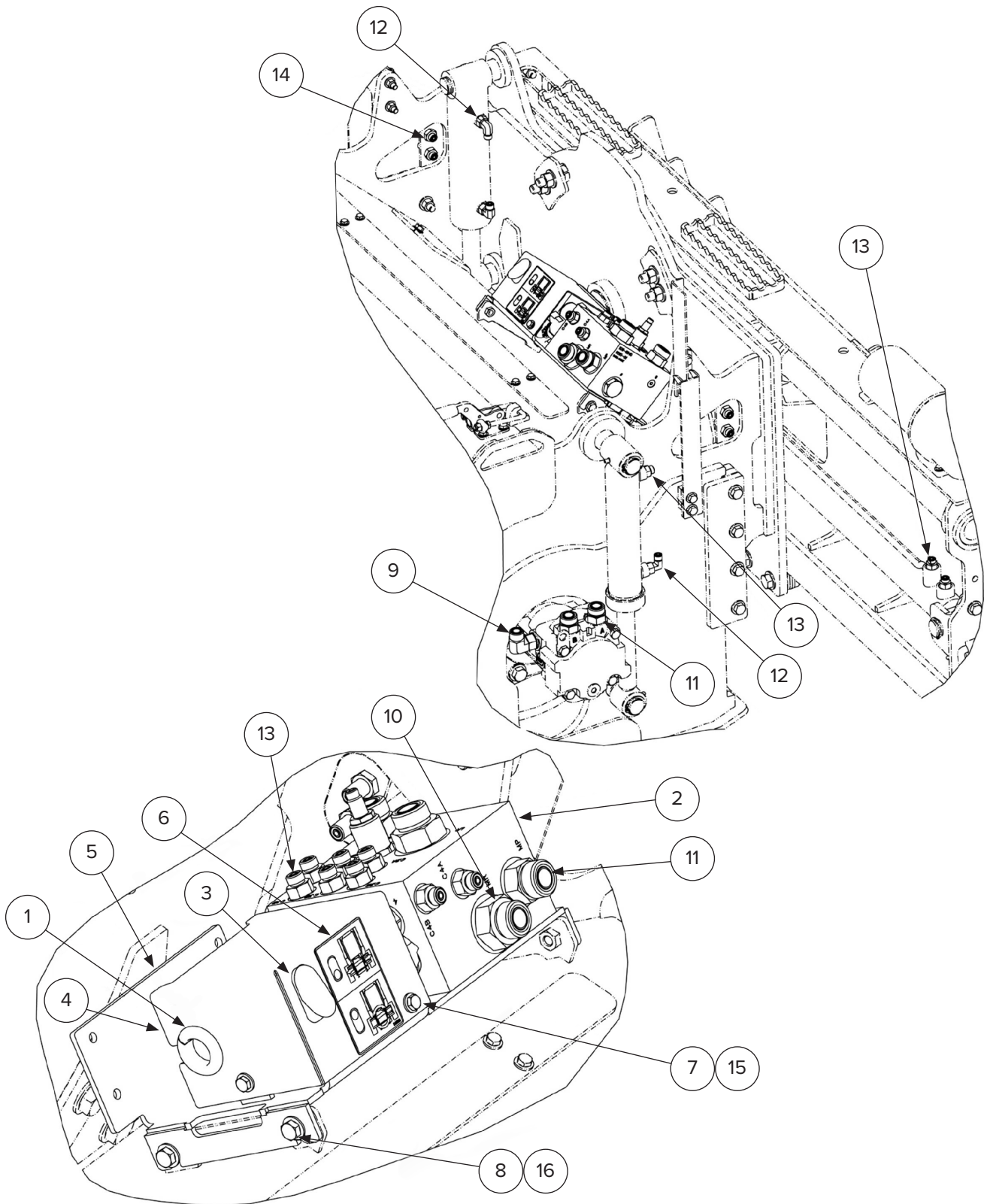

6. Diagrams & Parts

ITEM NO.	PARTS DESCRIPTION	COLD PLANERS ALL MODELS	QTY
1	Grommet	299900	1
2	Assembly, Valve 3 Line Dual Depth CP	260047 NOTE B	1
3	Switch, Rocker 6 Position DPDT	260021 NOTE A	1
4	Plate, Solenoid Cover	260235	1
5	Weldment, Valve Mount	260236	1
6	Decal, Planer Control	260237 NOTE A	1
7	Bolt, 1/4-20 X 0.75 Plated	299413	2
8	Bolt, 3/8-16 X 0.75 Plated	299424	4
9	Fitting, Elbow 90 10 ORFS, 10 STOR	295030-M10FS-M10ORB	1
10	Fitting, Straight 12 ORFS 16 SAE-ORB	295010-M12FS-M16ORB	2
11	Fitting, Straight 12 ORFS 12 STOR	260303	4
12	Fitting, Elbow 90 4 ORFS 6 STOR	295030-M04FS-M06ORB	4
13	Fitting, Straight 4 ORFS 6 STOR	295010-M04FS-M06ORB	12
14	Fitting, Bulkhead Straight 4 ORFS	295010-M04FSBH-M04FS	4
15	Washer, 1/4 Narrow Plated	216405	2
16	Washer, 3/8 Narrow Plated	216446	4

NOTE A: Kubota SSV Series Loaders do not use a switch. Tilt and side shift are selected with joystick controls.

NOTE B: All “-HP” models use 260047. Previous models use 260044.

6. Diagrams & Parts

6.9 Valve 3 Line Dual Depth Assembly

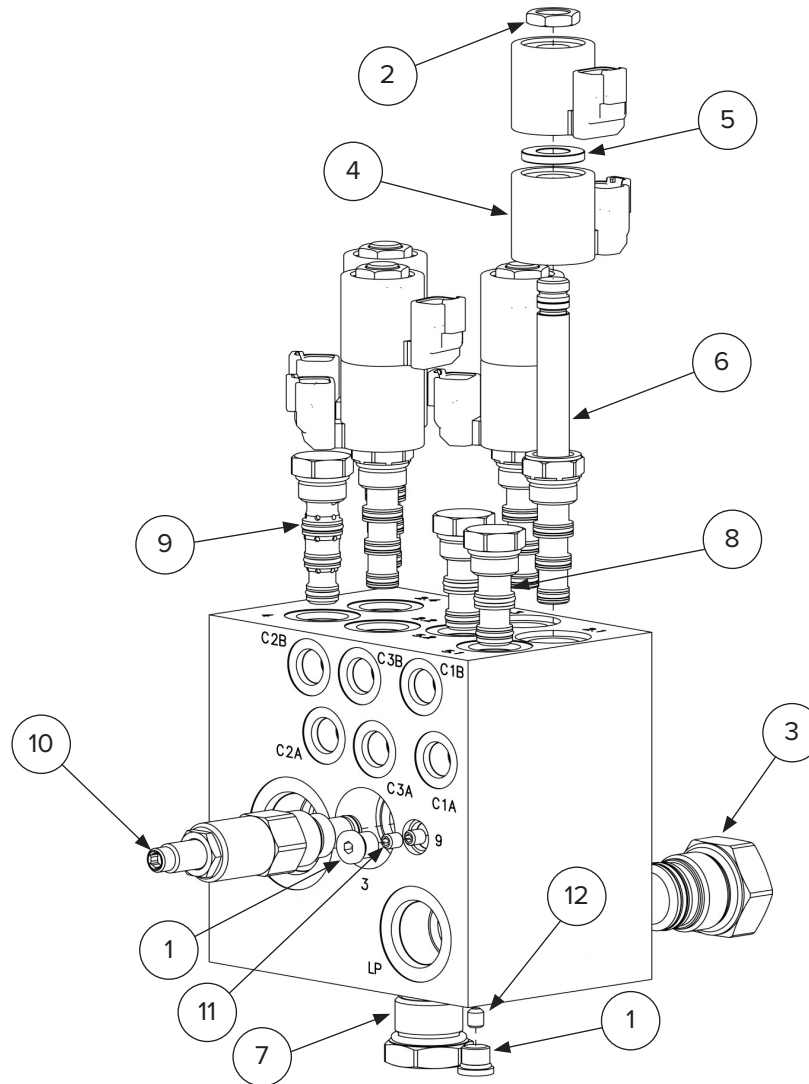

ITEM NO.	PARTS DESCRIPTION	COLD PLANERS ALL MODELS	QTY
1	Plug, 4 SAE-Orb Recessed Hex	295015-M04ORB	2
2	Nut, Coil Size 8 & 10	260043	4
3	Cartridge, Piloted Directional (Seal Kit: 260244)	260238	1
4	Coil, 08 Size	260239	8
5	Washer, 08 Size Coil	260240	4
6	Cartridge, Solenoid Valve (Seal Kit: 260048)	260039	4
7	Cartridge, Check Valve (Seal Kit: 260245)	260241	1
8	Cartridge, Check (Seal Kit: 260246)	260242	2
9	Cartridge, Dual Check Valve (Seal Kit: 260048)	260505	1
10	Cartridge, Relief (Seal Kit: 260048)	260039-RV08-22H	1
11	Plug, Orifice (0.05 In)	260031	1
12	Plug, Orifice (0.02 In)	260243	2

NOTE A: 260044 uses an aluminum manifold block and is rated to 3600 PSI; 260047 uses a ductile iron manifold block and is rated to 5000 PSI. Internal components are identical between the two assemblies.

6. Diagrams & Parts

6.10 3-Line Hydraulic Schematic

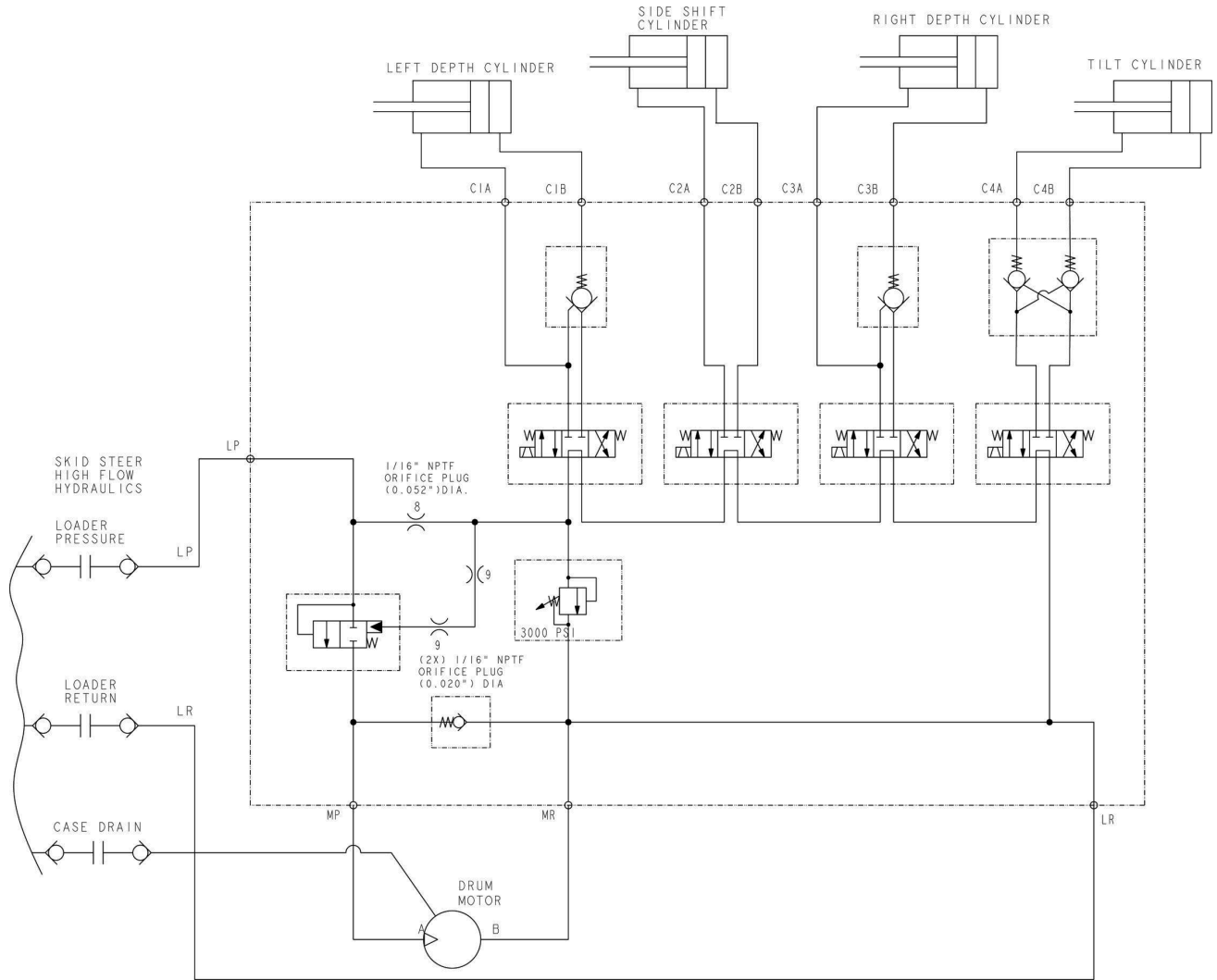

6. Diagrams & Parts

6.11 Electrical Parts

3 Line Wiring Harness Information (all except Kubota SSV Series)

The following harnesses connect to a 260078 adapter harness. The 260078 connects to the planer valve tilt and side shift solenoids. Match wire colors to connect these harnesses to the 260078 harness. These cold planers are equipped with a switch to select either side shift or tilt.

SKID STEER MODEL	HARNESS #
Bobcat A, S, and T Series (3 Line)	160415 Assembly (3 components, see below)
Caterpillar D Series & Later (3 Line)	160425
CASE 400 Series & Later (3 Line)	160400
GEHL (3 Line)	160400
JCB (3 Line)	160400
John Deere A, B, C Series (3 Line)	160430
John Deere D Series & Later (3 Line)	160435
Kubota Pre SSV Series (3 Line)	160400
New Holland (3 Line)	160400
Volvo (3 Line)	160400

3 Line Wiring Harness Information Kubota SSV Series

The KUBOTA SSV series use do not use a switch to select side shift or tilt. The trigger on the joystick is used to select one of these two functions. The 160427 harness connects directly to the planer valve. See Kubota SSV electrical schematic to connect this harness to the valve.

Loader Harness Service Parts

HARNESS #	LOADER SIDE CONNECTOR	LOADER SIDE SOCKET	LOADER SIDE TOOL	VALVE SIDE CONNECTOR	VALVE SIDE SOCKET	VALVE SIDE WEDGE	DIODE BOARD #
160400	260404 (14 pin)	260407	260391 (Blue)	260405	260407	260409	260356
160405							260403
160430							260356
160435							
160425							

3 Line Wiring Harness Information Bobcat A, S, & T Series

PART NUMBER	DESCRIPTION	FUNCTION
160415	Assembly for Bobcat A, S, & T Series	—
260415	Wiring Harness	Connects ACD Computer to Skid Steer Loader
260420	Bobcat ACD Computer	Computer (mounted on Cold Planer)
260076	Cold Planer Wire Harness	Connects jumper wires to ACD computer
260077	Jumper Wire	Connects 260076 harness to 260455 adapter harness (Qty: 6)

Connect 260076 harness to 260078 jumper adapter harness by using drawing on next page and notes below.

NOTE:

- 106-6545 Adapter Harness connects the ACD to the switch and only the tilt and sideshift solenoids.
- Match the Adapter Harness zip tie colors to the ACD Harness zip tie colors. White to white, gray to gray.
- Connect switch like all other units.
- Black zip tie wire on ACD Harness is not used.

6. Diagrams & Parts

6.12 Electrical Schematics

3 Line Wiring Schematic (all except Kubota SSV Series)

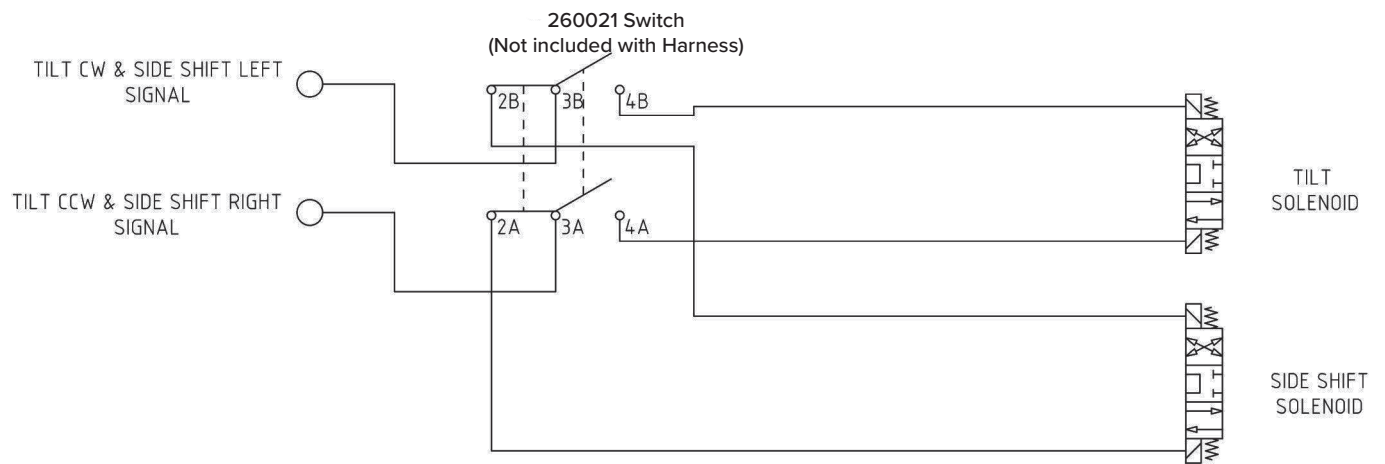

6. Diagrams & Parts

6.12 Electrical Schematics

Valve Connections Bobcat

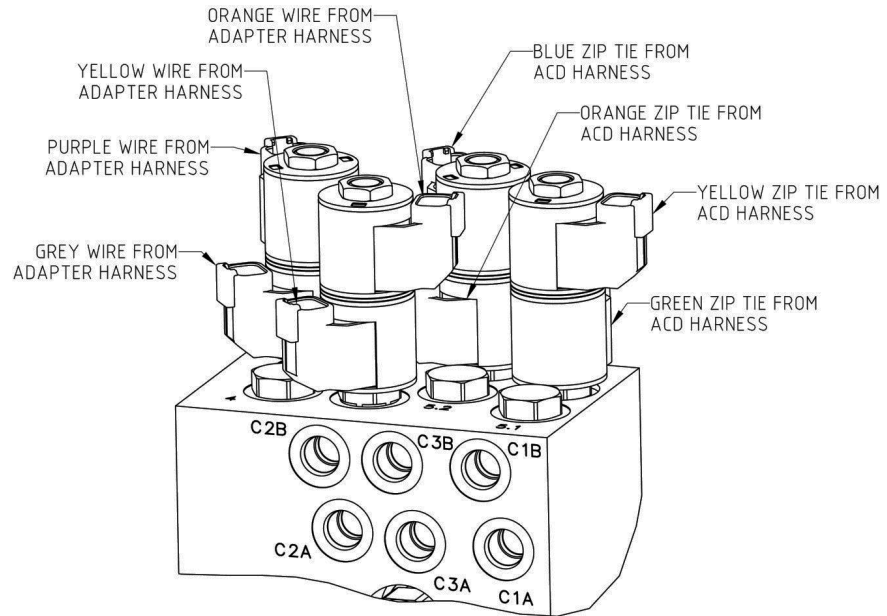

Valve Connections – Except Bobcat and Kubota (260078 Adapter Harness)

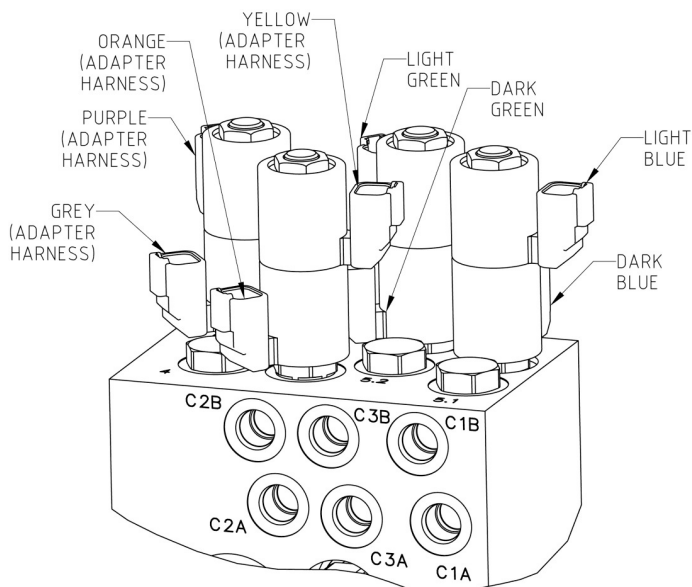

Switch Connections

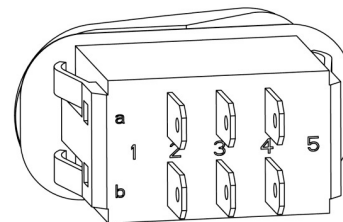

260078 ADAPTER HARNESS
CONNECTIONS TO SWITCH 260021

- a2: YELLOW
- a3: LT. BROWN
- a4: GRAY
- b2: ORANGE
- b3: BROWN
- b4: PURPLE

6. Diagrams & Parts

6.12 Electrical Schematics Cont'd

160427 Loader Harness Used on Kubota SSV

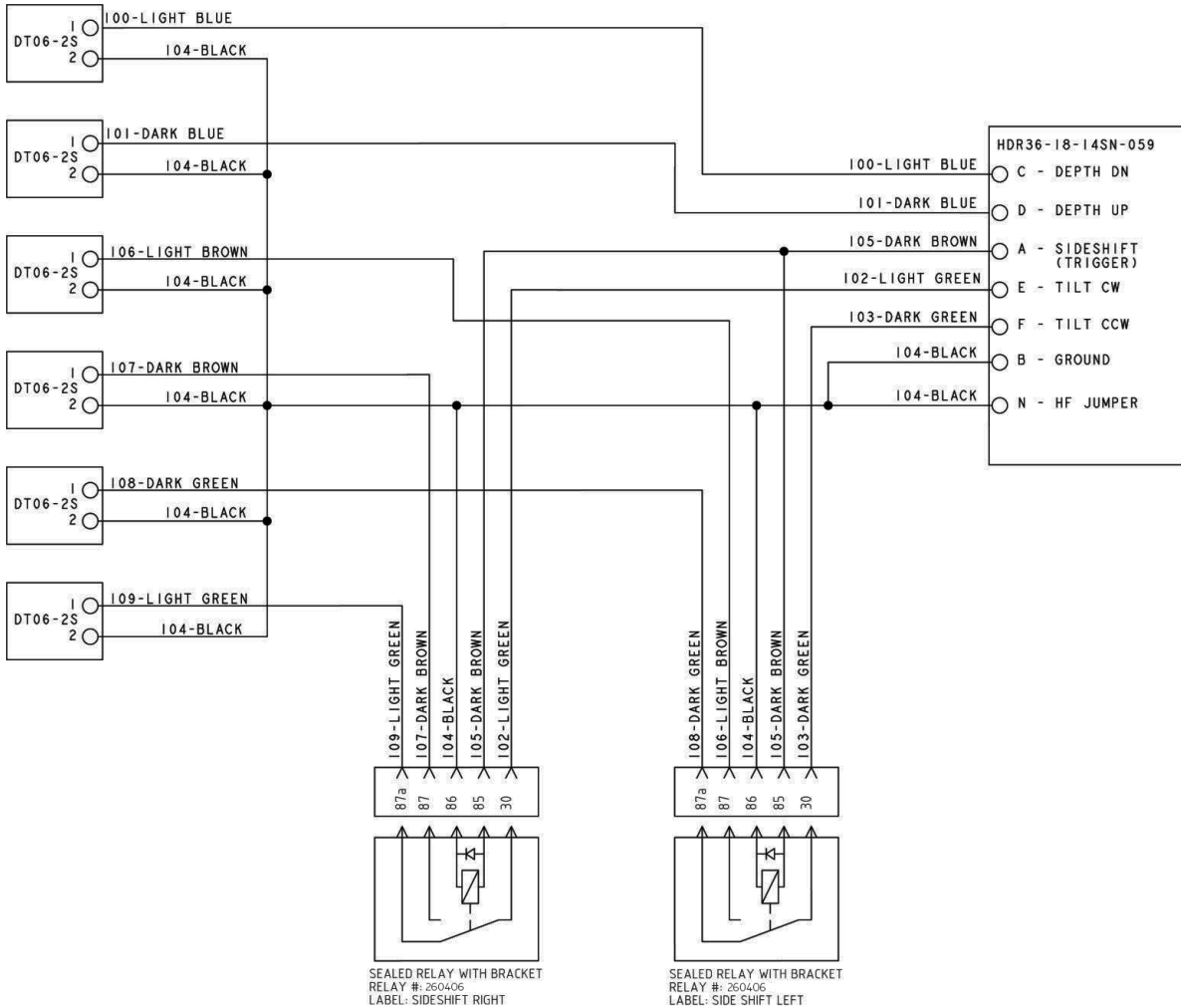

Valve Connections – Kubota

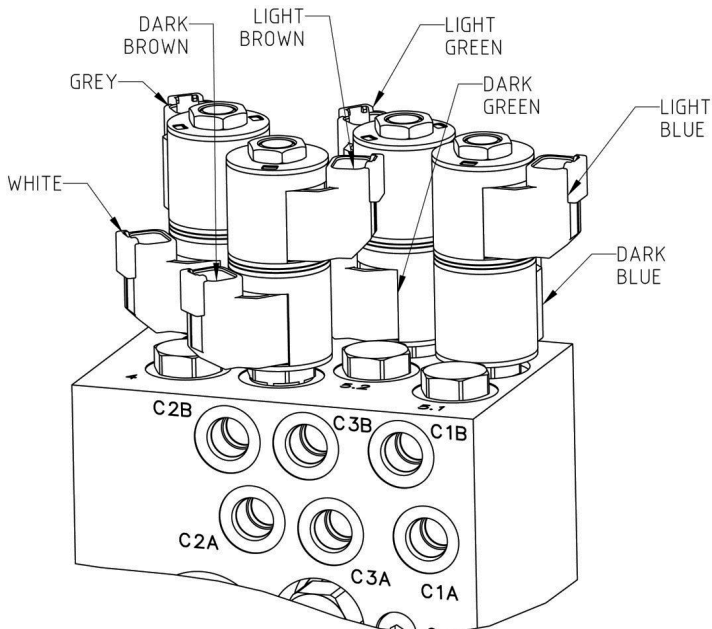

6. Diagrams & Parts

Harness Number 160400: CASE 400 Series & Later

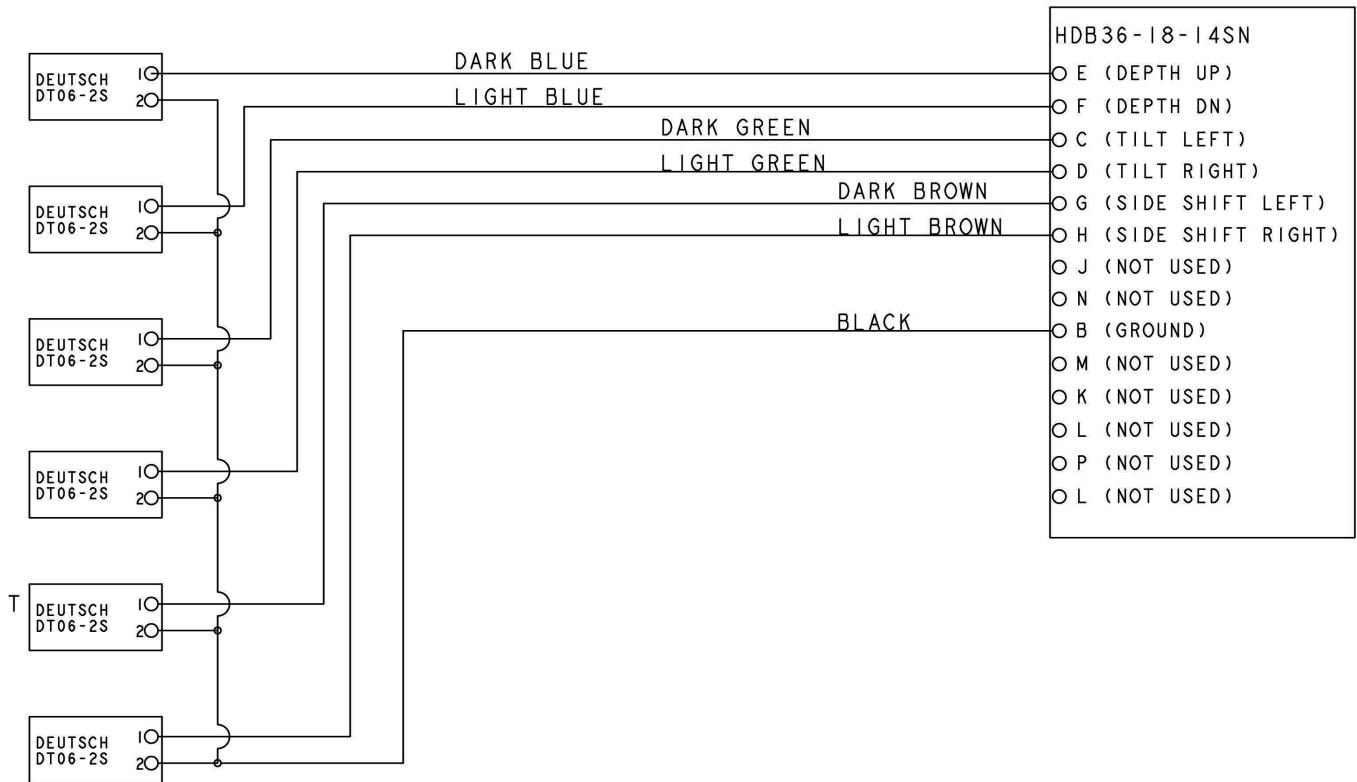

Harness Number 160430: John Deere A, B, C Series

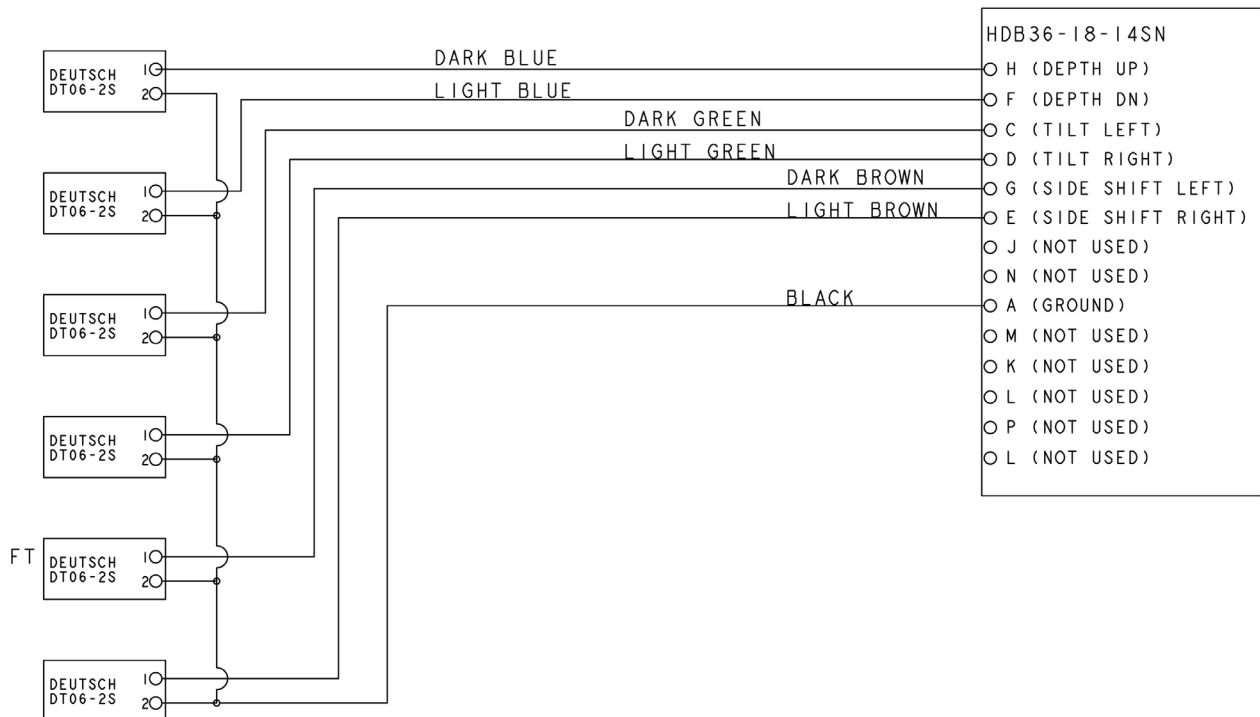

6. Diagrams & Parts

6.12 Electrical Schematics Cont'd

Harness Number 160435: John Deere D Series & Later

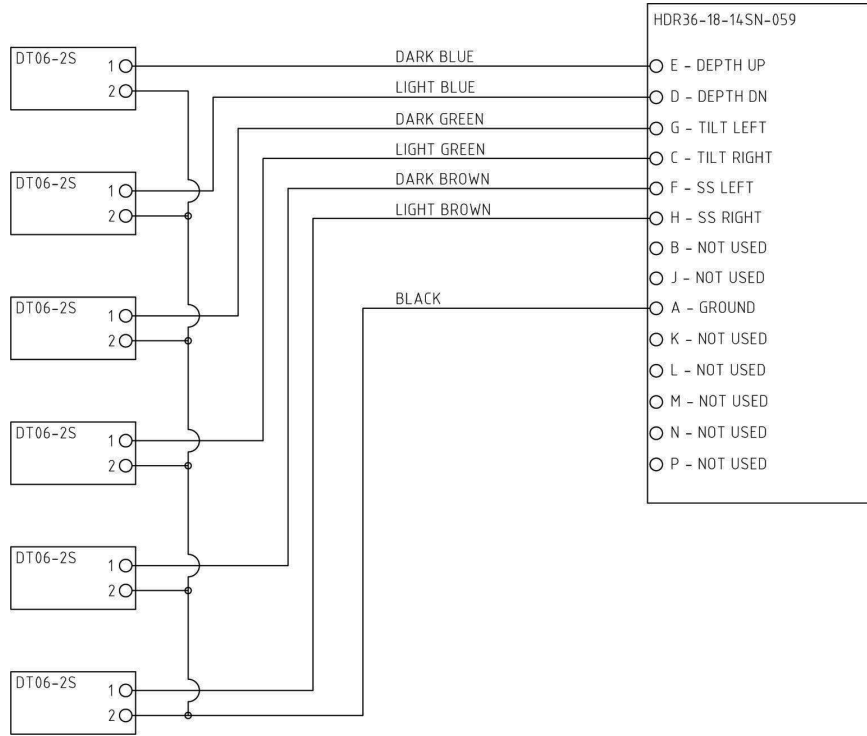

Harness Number 160425: Caterpillar D Series & Later

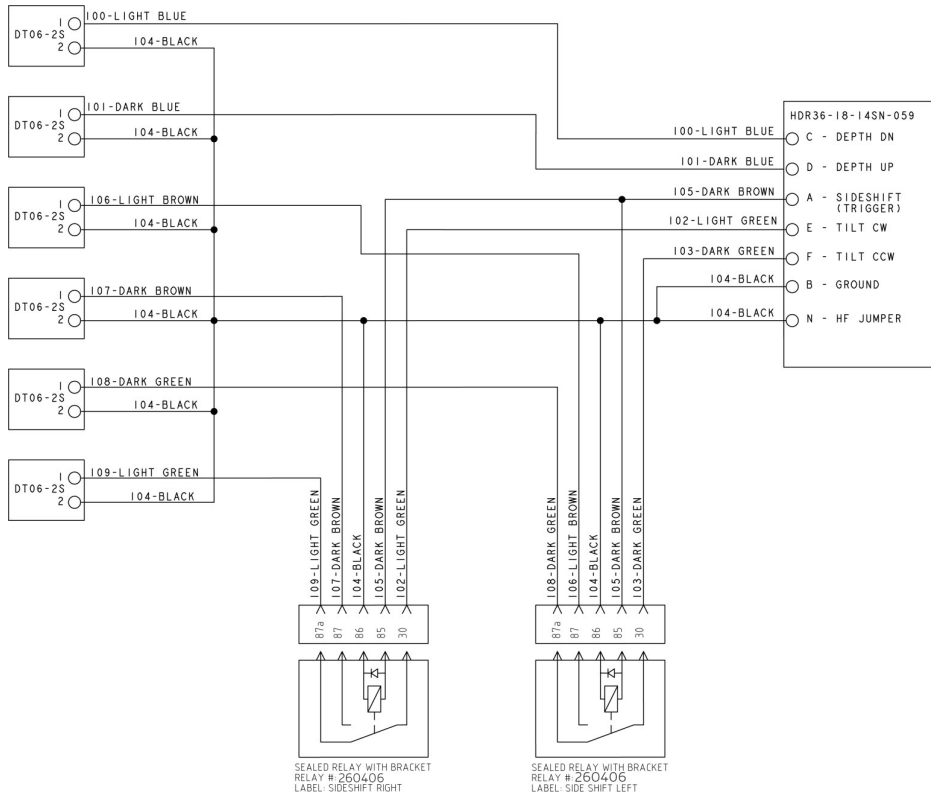

7. Troubleshooting

7.1 Depth, Tilt, and Side Shift Issues

STEP 1:

Check the skidsteer for proper power output at each of the pins at the skid steer's connector, using the schematic for that particular harness. Electrical harness information can be found in this manual beginning on page 36. Power should be present when pressing the corresponding button on the skid steer's joystick. For instance, "depth up" might be pin E on the plug. If there is no power at all, check the attachment control harness fuse on the skidsteer. If there is no power some pins and not others, then there might be a broken wire in the harness on the skidsteer. If all pins check good, move to step 2.

STEP 2:

Check for continuity from skid steer to each gray plug, at the end of the planer harness, where it plugs in to the solenoid coils on the hydraulic valve, highlighted in yellow. An easy way to check

without an ohm meter is to swap plugs with another coil and see if the problem follows the plug. If so, you have a harness problem. If not, move to step 3.

STEP 3:

You may have a defective coil (item 4). The coils become magnetic when energized, which is how the cartridges are shifted. If the coil has power at the plug, but isn't magnetic, replace the coil. Place a small steel screwdriver on the top of the cartridge valve stem to check for magnetism. Coil resistance should be 9.8 ohms $\pm 3\%$. If it is magnetic, move to step 4.

STEP 4:

You may have a bad cartridge, an example is circled below (item 6). Swap the suspected faulty cartridge with the one next to it, and if the problem follows the cartridge, replace the cartridge.

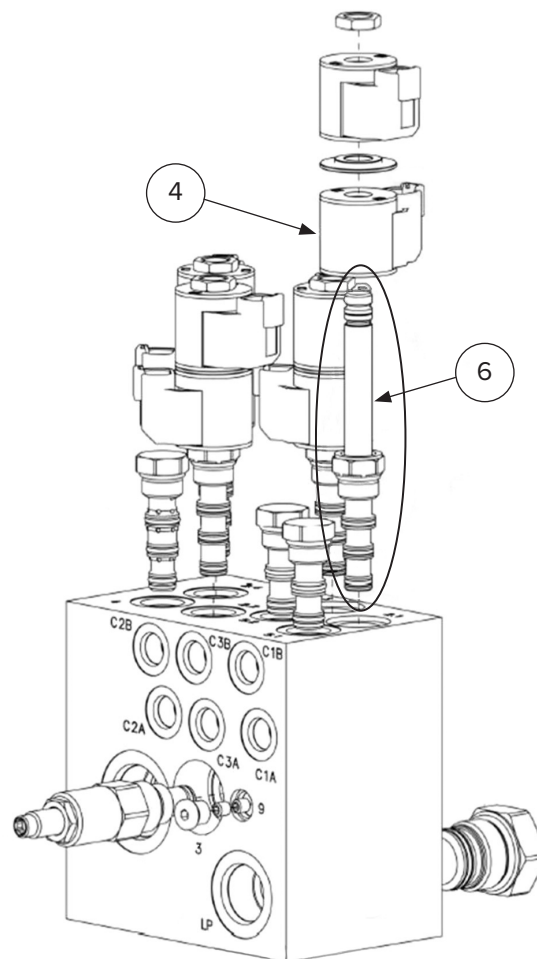

8. Specifications

8.1 Attachment Specifications

DESCRIPTION	160225-HP	160230-HP	160235-HP	160240-HP	160245-HP
Cutting Width (in)	18	24	30	40	48
Cutting Depth (in)	0 – 6				
Number of Teeth	46	56	66	76	106
Min. Hydraulic Flow (GPM)	24	27	30		
Max. Hydraulic Flow (GPM)	42				
Min. Pressure (PSI)	2000			3000	3500
Max. Pressure (PSI)	5000				
Tilt Capability (deg)	+/- 15	+/- 13	+/- 10	+/- 8	+/- 6
Side shift Travel (in)	26				
Approximate Weight (lb)	1805	1970	2155	2450	2685

DESCRIPTION	160810-HP	160815-HP	160820-HP	160825-HP	160830-HP
Cutting Width (in)	18	24	30	40	48
Cutting Depth (in)	0 – 8				
Number of Teeth	46	56	66	76	106
Min. Hydraulic Flow (GPM)	30		32	35	
Max. Hydraulic Flow (GPM)	42				
Min. Pressure (PSI)	3000		3250		
Max. Pressure (PSI)	5000				
Tilt Capability (deg)	+/- 15	+/- 13	+/- 10	+/- 8	+/- 6
Side shift Travel (in)	26				
Approximate Weight (lb)	1990	2225	2770	2910	3205

8. Specifications

8.2 Torque Specifications

Standard Hardware and Lock Nuts

BOLT TYPE	SAE GRADE 5		SAE GRADE 8		LOCK NUTS			
	Nominal Size	Plated or Unplated Silver	Plated W/ ZnCr Gold	Plated or Unplated Silver	Plated W/ ZnCr Gold	Plated or Unplated Silver	Plated W/ ZnCr Gold	W/ Grade 5 Bolt
1/4	55 in / lb (6.2 N•m)	72 in / lb (8.1 N•m)	86 in / lb (9.7 N•m)	112 in / lb (12.6 N•m)	121 in / lb (13.6 N•m)	157 in / lb (17.7 N•m)	61 in / lb (6.9 N•m)	86 in / lb (9.8 N•m)
5/16	115 in / lb (13 N•m)	149 in / lb (17 N•m)	178 in / lb (20 N•m)	229 in / lb (26 N•m)	250 in / lb (28 N•m)	325 in / lb (37 N•m)	125 in / lb (14 N•m)	176 in / lb (20 N•m)
3/8	17 ft / lb (23 N•m)	22 ft / lb (30 N•m)	26 ft / lb (35 N•m)	34 ft / lb (46 N•m)	37 ft / lb (50 N•m)	48 ft / lb (65 N•m)	19 ft / lb (26 N•m)	26 ft / lb (35 N•m)
7/16	27 ft / lb (37 N•m)	35 ft / lb (47 N•m)	42 ft / lb (57 N•m)	54 ft / lb (73 N•m)	59 ft / lb (80 N•m)	77 ft / lb (104 N•m)	30 ft / lb (41 N•m)	42 ft / lb (57 N•m)
1/2	42 ft / lb (57 N•m)	54 ft / lb (73 N•m)	64 ft / lb (87 N•m)	83 ft / lb (113 N•m)	91 ft / lb (123 N•m)	117 ft / lb (159 N•m)	45 ft / lb (61 N•m)	64 ft / lb (88 N•m)
9/16	60 ft / lb (81 N•m)	77 ft / lb (104 N•m)	92 ft / lb (125 N•m)	120 ft / lb (163 N•m)	130 ft / lb (176 N•m)	169 ft / lb (229 N•m)	65 ft / lb (88 N•m)	92 ft / lb (125 N•m)
5/8	83 ft / lb (112 N•m)	107 ft / lb (145 N•m)	128 ft / lb (174 N•m)	165 ft / lb (224 N•m)	180 ft / lb (244 N•m)	233 ft / lb (316 N•m)	90 ft / lb (122 N•m)	127 ft / lb (172 N•m)
3/4	146 ft / lb (198 N•m)	189 ft / lb (256 N•m)	226 ft / lb (306 N•m)	293 ft / lb (397 N•m)	319 ft / lb (432 N•m)	413 ft / lb (560 N•m)	160 ft / lb (217 N•m)	226 ft / lb (306 N•m)
7/8	142 ft / lb (193 N•m)	183 ft / lb (248 N•m)	365 ft / lb (495 N•m)	473 ft / lb (641 N•m)	515 ft / lb (698 N•m)	667 ft / lb (904 N•m)	258 ft / lb (350 N•m)	364 ft / lb (494 N•m)
1	213 ft / lb (289 N•m)	275 ft / lb (373 N•m)	547 ft / lb (742 N•m)	708 ft / lb (960 N•m)	773 ft / lb (1048 N•m)	1000 ft / lb (1356 N•m)	386 ft / lb (523 N•m)	545 ft / lb (739 N•m)



Warranty

MANUFACTURER'S LIMITED WARRANTY

BLUE DIAMOND® ATTACHMENTS, a manufacturer of quality attachments, warrants new BLUE DIAMOND® ATTACHMENTS products and/or attachments at the time of delivery to the original purchaser, to be free from defects in material and workmanship when properly set up and operated in accordance with the recommendations set forth by BLUE DIAMOND® ATTACHMENTS, LLC.

BLUE DIAMOND® ATTACHMENTS liability for any defect with respect to accepted goods shall be limited to repairing the goods at a BLUE DIAMOND® ATTACHMENTS designated location or at an authorized dealer location, or replacing them, as BLUE DIAMOND® ATTACHMENTS shall elect. The above shall be in accordance with BLUE DIAMOND® ATTACHMENTS warranty adjustment policies. BLUE DIAMOND® ATTACHMENTS obligation shall terminate twelve (12) months for the High Flow Cold Planer after the delivery of the goods to original purchaser.

This warranty shall not apply to any machine or attachment which shall have been repaired or altered outside the BLUE DIAMOND® ATTACHMENTS factory or authorized BLUE DIAMOND® ATTACHMENTS dealership or in any way so as in BLUE DIAMOND® ATTACHMENTS judgment, to affect its stability or reliability, nor which has been subject to misuse, negligence or accident beyond the company recommended machine rated capacity.

WARRANTY CLAIM

To submit a warranty claim, a claim must be filed with BLUE DIAMOND® ATTACHMENTS before work is performed. The BLUE DIAMOND® PRODUCT SUPPORT TEAM will advise repairs and applicable parts exchanges. Tampering with the failed part may void the warranty. This warranty does not include freight or delivery charges incurred when returning machinery for servicing. Dealer mileage, service calls, and pickup/delivery charges are the customers' responsibility.

EXCLUSIONS OF WARRANTY

Except as otherwise expressly stated herein, BLUE DIAMOND® ATTACHMENTS makes no representation or warranty of any kind, expressed or implied, AND MAKES NO WARRANTY OF MERCHANTABILITY IN RESPECT TO ITS MACHINERY AND/OR ATTACHMENTS ARE FIT FOR ANY PARTICULAR PURPOSE. BLUE DIAMOND® ATTACHMENTS shall not be liable for incidental or consequential damages for any breach or warranty, including but not limited to inconvenience, rental of replacement equipment, loss of profits or other commercial loss. Upon purchase, the buyer assumes all liability for all personal injury and property resulting from the handling, possession, or use of the goods by the buyer.

No agent, employee, or representative of BLUE DIAMOND® ATTACHMENTS has any authority to bind BLUE DIAMOND® ATTACHMENTS to any affirmation, representation, or warranty concerning its machinery and/or attachments except as specifically set forth herein.

This warranty policy supersedes any previous documents.

NOTE: Blue Diamond® Attachments is a trademark of BLUE DIAMOND® ATTACHMENTS



QUALITY | DEPENDABILITY | INTEGRITY

Blue Diamond® Attachments
4512 Anderson Road, Knoxville, TN 37918
888-376-7027