

Severe Duty Grapple Bucket

Operation and Maintenance Manual



Register your
WARRANTY
within 30 days
of purchase



888-376-7027 | BlueDiamondAttachments.com



BD-092

Introduction: Owner Information

Thank you for your decision to purchase a Blue Diamond® Severe Duty Grapple Bucket. To ensure maximum performance of your equipment, it is mandatory that you thoroughly study the Operator's manual and follow the recommendations. Proper operation and maintenance are essential to maximize equipment life and prevent personal injury.

Operate and maintain this equipment in a safe manner and in accordance with all applicable local, state, and federal codes, regulations and /or laws. Follow all on-product labeling and instructions.

Make sure that all personnel have read this Operator's Manual and thoroughly understand safe and correct operating, installation and maintenance procedures.

Blue Diamond is continually working to improve its products. Blue Diamond reserves the right to make any improvements or changes as deemed practical and possible without incurring any responsibility or obligation to make any changes or additions to equipment sold previously.

Although great care has been taken to ensure the accuracy of this publication, Blue Diamond makes no warranty or guarantee of any kind, written or expressed, implied or otherwise with regard to the information contained within this manual. Blue Diamond assumes no responsibility for any errors that may appear in this manual and shall not be liable under any circumstances for incidental, consequential or punitive damages in connection with, or arising from the use of this manual.

Keep this manual available for frequent reference. All new operators or owners must review the manual before using the equipment and annually thereafter. Contact your Blue Diamond Attachments Dealer for assistance, information, or additional copies of the manual. Contact www.bluediamondattachments.com or call 888-376-7027 for a complete list of dealers in your area.

Serial Number Location:

Please record attachment information in the space provided for future reference.



Model Number: _____

Serial Number: _____

Dealer Name: _____

Dealer Number: _____

Date of Purchase: _____

The serial number plate is located on the back of the frame to the right of the mounting plate.

Always use your serial number when requesting information or when ordering parts.

NOTE: The directions left, right, front and rear, as mentioned throughout this manual, are as viewed from the operator's position.

Table of Contents

1. Introduction.....	4-5
1.1 Attachment Identification.....	4
1.2 About this Attachment.....	5
1.3 Attachment Model Numbers.....	5
2. Safety.....	6-7
2.1 General Safety Information.....	6
2.2 Qualified Operators.....	7
3. Operation.....	8-9
3.1 Entering and Exiting the Prime Mover.....	8
3.2 Attachment Installation.....	8
4. Inspections and Maintenance.....	10-11
4.1 Equipment Inspections.....	10
4.2 Usage Guidelines.....	10
4.3 Lubrication Points.....	11
4.4 Inspection Checklist.....	11
5. Parts.....	12-15
5.1 Main Parts Breakdown.....	12
5.2 Hose Breakdown.....	15
6. Specifications.....	16-17
6.1 Attachment Specifications.....	16
6.2 Torque Specifications.....	17
7. Warranty.....	19

1. Introduction

1.1 Attachment Identification

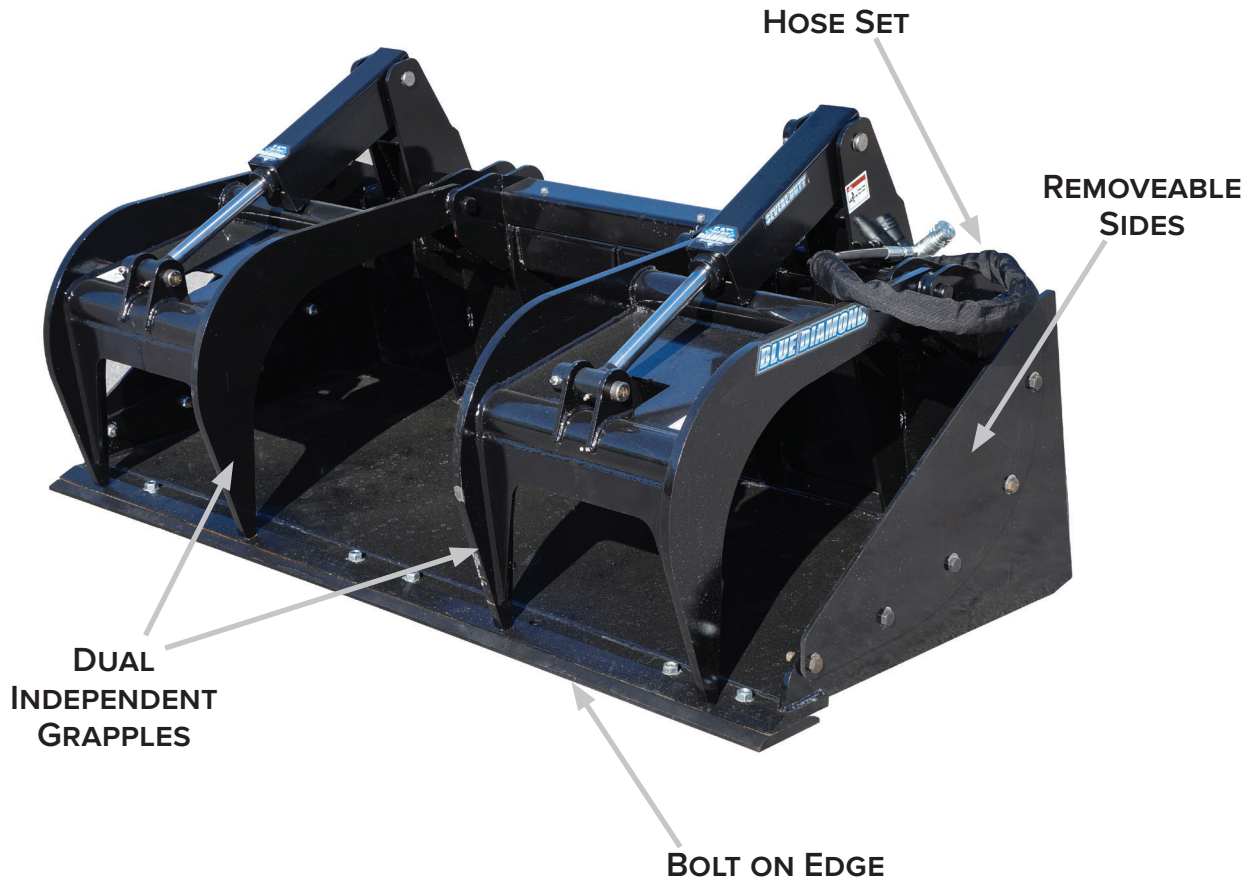

1. Introduction

1.2 About this Attachment

About the Grapple Bucket Attachment

The grapple bucket attachment is intended for use in materials handling. The primary use of the grapple bucket attachment includes land clearing, landscaping, demolition, construction, and grounds maintenance. Use of this equipment in any other manner is considered to be contrary to the intended use of the attachment.

Grapple Buckets

The grapple bucket is quickly becoming a necessity among all contractors today. This unique grapple bucket is offered in a variety of sizes for a variety of applications.

The Severe Duty Grapple Bucket attachment combines the loading and leveling actions of a skid steer bucket with the “grabbing ability” of two hydraulic grapples. The basic design of the grapple bucket attachment allows it to load and grapple large and/or uneven objects. The bucket is also designed to pick up the smallest debris. Our grapple buckets feature enclosed cylinders and hoses to protect against debris and stray limbs. The depth of the bucket has been increased, giving it a large loading capacity and the reinforced ribbed bottom reduces bowing and wear of the grapple bucket. The Severe Duty grapple bucket also has removable sides for optional increased volume of smaller debris. With our new design you will have an unobstructed view of the materials entering and exiting the skid steer attachment. No other skid steer grapple bucket attachment on the market provides these essential features.

The grapple bucket is available in 5 sizes: 60”, 66”, 72”, 78”, and 84”!

1.3 Attachment Model Numbers

SEVERE DUTY GRAPPLE BUCKET	MODEL NUMBERS
60”	106429
66”	106444
72”	106454
72” with teeth	106457
78”	106464
84”	106476
84” with teeth	106474

2. Safety

2.1 General Safety Information



This **SAFETY ALERT SYMBOL** identifies important safety messages on the equipment and in the owner's manual. When you see this symbol, be alert to the possibility of personal injury and carefully read the message that follows.



The signal word **IMPORTANT** identifies procedures which must be followed to avoid damage to the machine.



The signal word **DANGER** on the machine and in the manuals indicates a hazardous situation which, if not avoided, will result in death or serious injury.



The signal word **WARNING** on the machine and in the manuals indicates a potentially hazardous situation which, if not avoided, could result in death or serious injury.



The signal word **CAUTION** on the machine and in the manuals indicates a potentially hazardous situation which, if not avoided, may result in minor or moderate injury. It may also be used to alert against unsafe practices.

NOTE: Notes are used to indicate important information. This information may be repeated in other areas of the manual.

Terminology

Prime Mover: The grapple bucket can be attached to many different pieces of equipment; therefore, the term “prime mover” will be used. A prime mover is any equipment, tractor, or skid steer providing power to the attachment.

Operating Safety

- Read and follow instructions in this manual and the machine's Operators Manual before operating.
- The manual must always remain with the machine. In case of loss or damage, request a new copy from your dealer or from Blue Diamond.
- Only qualified and trained operators should operate, maintain, and service this attachment. See section 2.2 on page 7 to determine a qualified operator.
- Strictly follow all rules prescribed by the safety pictograms/decals applied to the machine. Ensure that all safety pictograms/decals are legible. If pictograms/decals are worn, they must be replaced with new ones obtained from Blue Diamond and placed in the position indicated by this manual.
- Before using the machine, make sure that all safety devices are installed and in good working conditions. In case of damaged or missing shields, replace them immediately.
- It is absolutely forbidden to remove or alter safety devices and/or safety precautions
- Pay maximum attention to avoid any accidental contact with rotating parts of the machine.
- If the use of the machine is required at night or in conditions of reduced visibility, use the lighting system of the prime mover and possibly an auxiliary lighting system.

Modifications to Equipment

Any modifications made to this equipment may void any warranty and relieve the manufacturer of liability of any resulting injury or damage.

2. Safety

2.2 Qualified Operators

Qualified Operators

The operator is a person suited to the work and who is physically and psychologically able to withstand the demands connected with operating the equipment for its intended use. The operator must not allow anyone to approach the machine while it is working and must not allow external personnel to operate the machine or attachment.

He is to follow the given instructions in this manual and the machine operator's manual in order to obtain maximum performance, minimum consumption, and maximum safety for himself and for others.

The operator is responsible for scrupulously observing all the instructions given in this manual.



DANGER



AVOID SERIOUS INJURY OR DEATH

Operators must receive instructions before operating the machine. Untrained operators can cause serious injury or death.

For an operator to be qualified, he or she must not use drugs or alcoholic drinks which impair alertness or coordination while working. An operator who is taking prescription drugs must get medical advice to determine if he or she can safely operate a machine and the equipment. For an operator to be qualified, he or she must have read and understood the instructions of this manual, he or she must make adequate preparation for the proper use of the machine, and he or she must hold a driving license.

In case of doubt regarding the use of the machine and/or the interpretation of this manual, the operator must contact either their dealer or Blue Diamond.

Operator Training

- Check the rules and regulations at your location. The rules may include an employer's work safety requirements. Regulations may apply to local driving requirements or use of a Slow Moving Vehicle (SMV) emblem. Regulations may identify a hazard such as a utility line.
- The new operator must start in an area without bystanders and use all the controls until he or she can operate the machine safely under all conditions of the work area.

Operator Safety

- It is the responsibility of the operator to follow all local, state, and federal safety regulations. Improper use of this equipment may result in personal injury, property damage, and/or damage to the equipment.
- Before starting, and during operation of the attachment, make sure there are no people or animals in the operation area; the machine can project material from the back with risks of serious injury or death.
- During operation, adjustment, maintenance, repairing, or transportation of the machine, the operator must always use appropriate Personal Protective Equipment (PPE) including but not limited to safety glasses, working gloves, dust-mask, safety helmet, and hearing protection.

NOTE: Additional safety equipment may be required depending on the operating environment and worksite conditions.

- Do not operate the attachment or machine while wearing loose fitting clothing that can be entangled or caught in parts of the machine.
- Do not operate the implement when tired, not in good health condition, or under the influence of alcohol or drugs.

3. Operation

3.1 Entering and Exiting the Prime Mover

IMPORTANT



See the machine's Operator's Manual for detailed information on operating the loader.

Entering the Operator's Position

Use the attachment safety treads, handles and steps (on the machine) to enter the operator's position.

When in the operator's position, lower safety seat bar, start the engine and release the parking brake.

Leaving the Operator's Position

WARNING

AVOID SERIOUS INJURY OR DEATH

- Always park on a flat level surface.
- Place attachment flat on the ground.
- Place all controls in **NEUTRAL**.
- Engage the park brake.
- Stop the engine and remove the key.
- Wait for all moving parts to stop.

SEE MACHINE'S OPERATOR'S MANUAL FOR ADDITIONAL INFORMATION.

Park the machine/attachment on a flat level surface.

Place all controls in neutral, engage the park brake, stop the engine and wait for all moving parts to stop. Leave the operator's position.

3.2 Attachment Installation

Connecting Attachment To The Prime Mover

NOTE: Before attempting to attach the grapple bucket to the prime mover, verify that all hydraulic couplings are compatible.

WARNING

Improper attachment to the prime mover may cause personal injury.

CAUTION

All hydraulic connections must be clean and free of debris before making any connection.

1. Place the grapple bucket attachment on a level surface.
2. Position the prime mover facing the attachment close to the mount.
3. Insert and connect the prime mover into the attachment.
4. Connect the hydraulic lines from the attachment to the prime mover.
5. Close latches (or other locking mechanism) to secure the attachment to the prime mover.

WARNING

AVOID SERIOUS INJURY OR DEATH

The locking mechanism must extend through the holes in the attachment mounting frame. Failure to secure locking mechanism can allow attachment to come off.

SEE MACHINE'S OPERATOR'S MANUAL FOR ADDITIONAL INFORMATION.

3. Operation

3.2 Attachment Installation Cont'd

Connecting Attachment to the Prime Mover Cont'd

- Using the prime mover, raise the attachment and move the attachment to ensure hydraulic lines are clear of air and operate properly.



CAUTION



Hydraulics should operate in an even and smooth manner. Hydraulic movement that is not even and smooth may indicate that air is in the hydraulic lines.

- Lower the attachment to ground level
- Inspect that the attachment is mounted properly and securely. If the attachment does not meet this requirement, follow the instructions to remove the grapple bucket and re-attach using the instructions above.

Disconnecting Attachment From the Machine



WARNING



Improper disconnection from the prime mover may cause personal injury or damage to the attachment and prime mover.



CAUTION



All hydraulic connections must be clean and free of debris before making any disconnection.

- Using the prime mover, lower the attachment to the ground.
- To prevent contamination, remove any dirt and debris from the couplings. Disconnect the hydraulic connection between the attachment and the prime mover.

NOTE: Hydraulic connections must be disconnected before disengaging latches to prevent damage to the prime mover or the attachment.

- Disengage the prime mover latches (or other locking mechanism) from the attachment.
- Move the prime mover away from the attachment.

4. Inspections and Maintenance

4.1 Equipment Inspection

It is recommended to inspect the equipment for damage and wear before use. Use the following list as a guideline during equipment inspection.

- Check all hardware connections to the prime mover for damage or fatigue such as cracks or other structural flaws.
- Check that all latches or locks are closed.
- Check that all hydraulic fittings are tight and free of leaks.
- Check that all hydraulic lines are free of leaks, holes, or cracks.

WARNING



Leaking fluids under pressure can enter the skin and cause serious injury or death. Immediate medical attention is required. Wear goggles. Use cardboard to check for leaks.

- Check that the tires on the prime mover are in good condition and have proper load ratings.

NOTE: Replace any damaged hardware, hoses, and fittings before using the equipment.

4.2 Usage Guidelines

Before each use do the following:

- Perform the equipment inspection by performing a walk around.
- Perform daily inspection as indicated in the Inspection Checklist found in section 4.4 on page 11.
- Verify that the proper attachment is being used for the task. Use the grapple bucket for materials handling only.

DANGER

Keep all body parts away from the grapple bucket when in use. The upper tines may open or close unexpectedly causing serious bodily injury or death.

Inspect the grapple bucket daily before use. It is also recommended to inspect the grapple bucket after extreme use or damage. Use the following inspection checklist as a guideline.

4. Inspections and Maintenance

4.3 Lubrication Points

Grease all pivot points every 8 hours of use to prevent excess wear on the pins. The Severe Duty Grapple Bucket has 8 grease points. These 8 points are circled below in Figure 1.

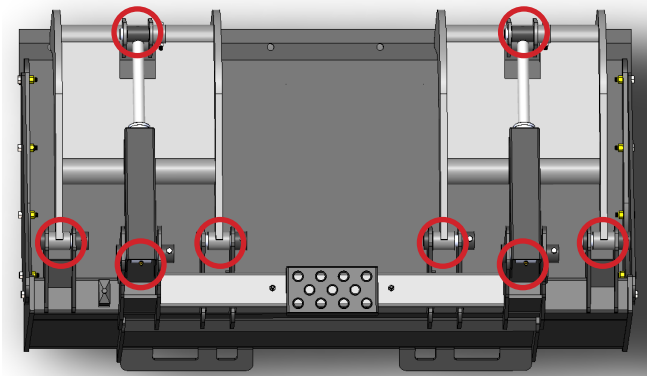

Figure 1

4.4 Inspection Checklist

	ITEMS
✓	Are all safety notices and warning stickers in proper locations and visible?
✓	Are there any visible hydraulic leaks?
✓	Are any cracks visible in the grapple bucket structure?
✓	Are the tines worn or bent?
✓	Have all grease fittings (zerk fittings) been greased?
✓	Are the bolts holding pins secure and tight?
✓	Has the prime mover been properly inspected for hydraulic leaks and proper tire inflation?
✓	Has the prime mover been properly maintained?

5. Parts

5.1 Main Parts Breakdown

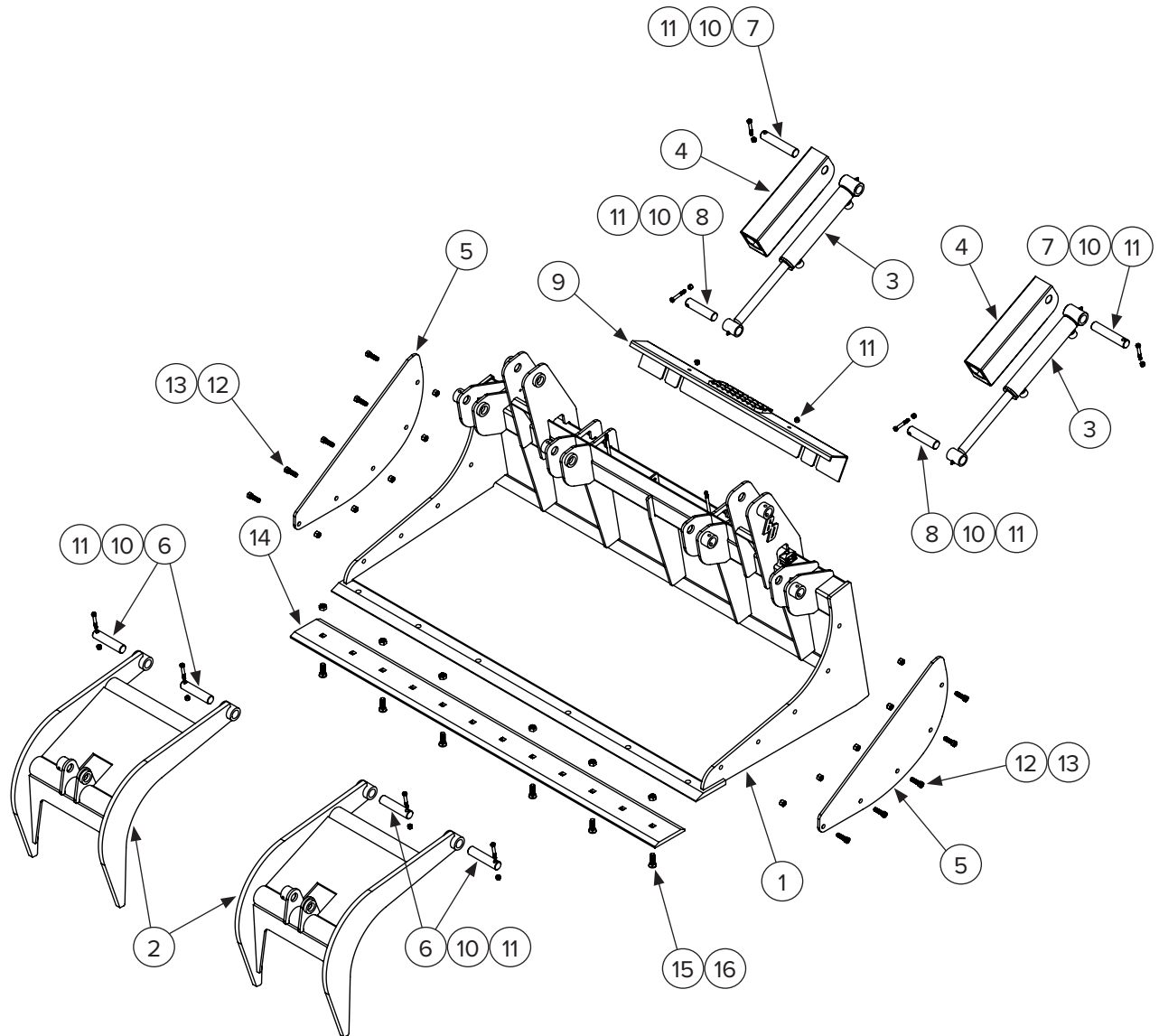

5. Parts

5.1 Main Parts Breakdown

ITEM	PART NUMBER	DESCRIPTION	QTY
1	206429	Grapple Bucket Main Frame - 60"	1
	206444	Grapple Bucket Main Frame - 66"	
	206454	Grapple Bucket Main Frame - 72"	
	206464	Grapple Bucket Main Frame - 78"	
	206476	Grapple Bucket Main Frame - 84"	
	206429-16	Grapple Bucket Frame; EURO AG - 60"	
2	206400	Grapple Claw Weldment – Bucket; Rock Bucket	2
3	206306	2-inch bore, 10-inch stroke, 3/8-inch ports	2
4	206316	Cylinder Cover	2
5	206410	SD Grapple Bucket – Side Attachment Plate	2
6	206415	Pin 1.25 X 5.5	4
7	206406	Pin 1.25 X 6.25	2
8	206343	Pin 1.25 X 5.25	2
9	203262	Hose Cover with Step 60"	1
	206259	Hose Cover with Step 66"	
	206255	Hose Cover with Step 72", 78", & 84"	
10	299329	Hex Bolt – Grade 8 – 3/8"-16 X 2 1/2"	8
11	299625	Locknut – Gr8 – 1/2-13	10
12	299439	Grade 8 – Hex Bolt – 1/2"-13 X 1 3/4"	10
13	299618	Locknut – Gr8 – 1/2-13	10
14	109115*	Cutting Edge – Bolt On – 60"	1
	109120*	Cutting Edge – Bolt On – 66"	
	109125*	Cutting Edge – Bolt On – 72"	
	109130*	Cutting Edge – Bolt On – 78"	
	109140*	Cutting Edge – Bolt On – 84"	
15	109176	5/8"-11 X 2.00 Plow Bolt – Grade 8	6
16	109177	Stover Nut – Grade 8 – 1/2"-13	6
*Change to 3091XX to include hardware			

5. Parts

5.2 Hose Breakdown

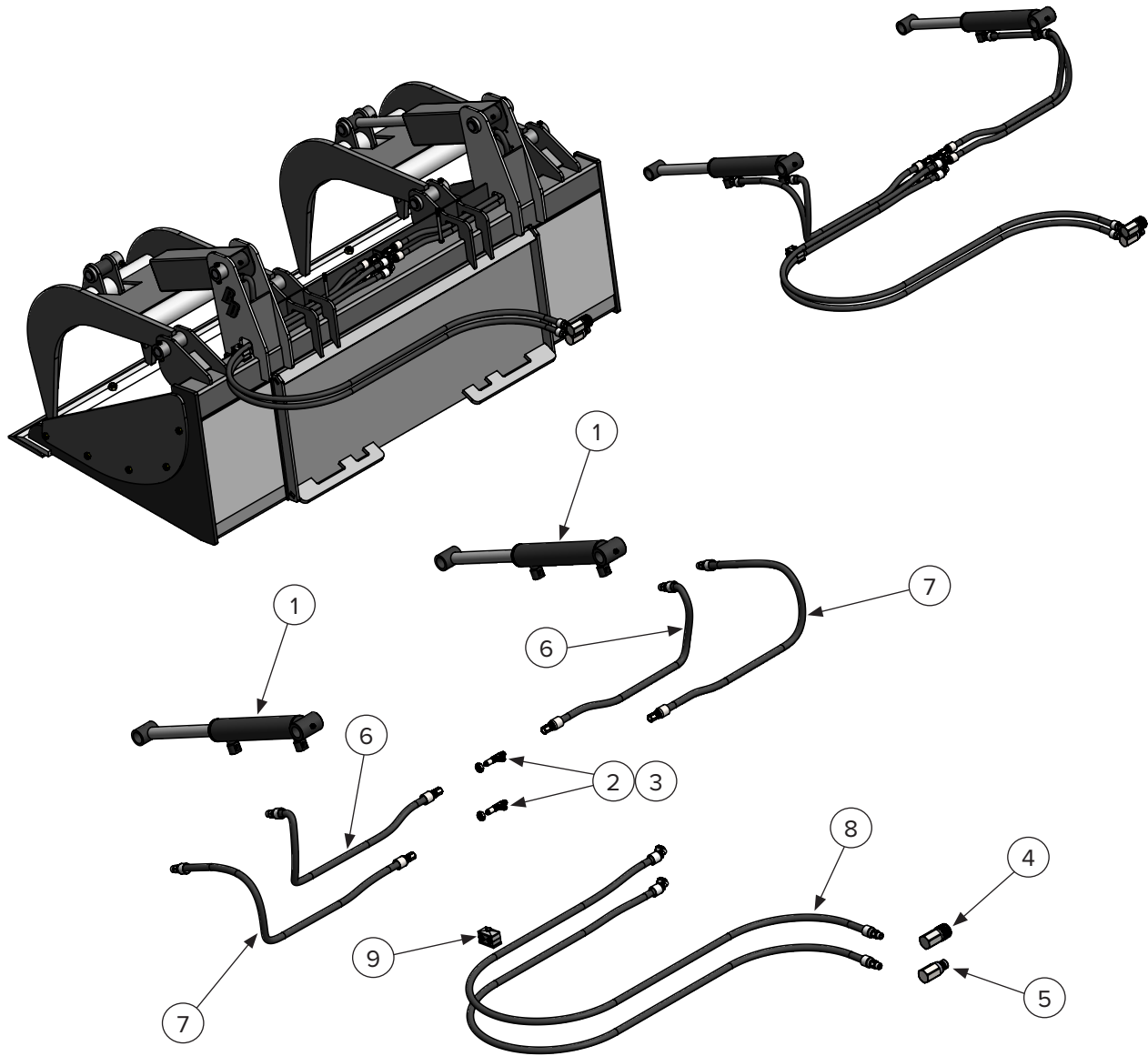

5. Parts

5.2 Hose Breakdown

ITEM	PART NUMBER	DESCRIPTION	QTY
1	206306	2" Bore, 10" Stroke, 3/8" Ports	2
2	206354	Bulkhead Tee; (-6) Male JIC 37°	2
3	295052	Bulkhead Tee Nut 9/16-18 Nut	2
4	224007	Coupler, 1/2" Female Flat Face, 3/8" NPT with 90 Degree Angle	1
5	224008	Coupler, 1/2" Male Flat Face, 3/8" NPT with 90 Degree Angle	1
6	206256	Short Cylinder Hose 72/78/84 (Length 32" Each)	1
	206261	Short Cylinder Hose 60/66 (Length 30" Each)	
7	206254	Long Cylinder Hose 72/78/84 (Length 43" Each)	1
	206260	Long Cylinder Hose 60/66 (Length 41" Each)	
8	206252	Machine Hoses with Sleeve (Length 86" Each)	1
9	206246	Hose Clamp – Weld Mount 11/16"	1
NS	206250	Full Hose Set	—
** 3/8" Hydraulic Hose 4785 PSI			

6. Specifications

6.1 Attachment Specifications

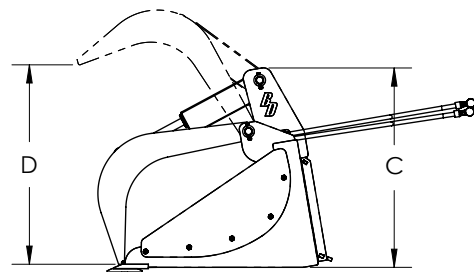
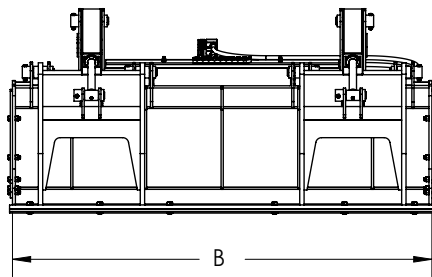
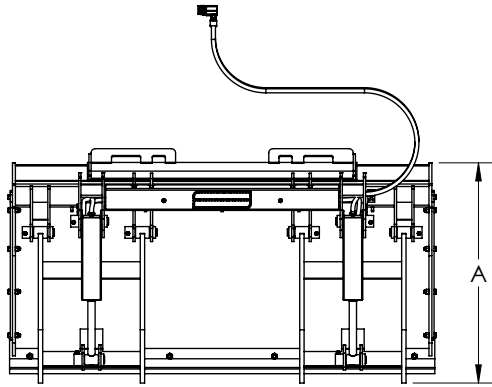

DESCRIPTION	60"	66"	72"	78"	84"
Overall Height (A)	37.80 in				
Overall Width (B)	60"	66"	72"	78"	84"
Overall Height (grapple extended) (C)	34 1/4"				
Opening Height (D)	34 1/4"				
Max Pressure	3000 PSI				

6. Specifications

6.2 Torque Specifications

Standard Hardware and Lock Nuts

BOLT TYPE	SAE GRADE 5		SAE GRADE 8		LOCK NUTS			
	Nominal Size	Plated or Unplated Silver	Plated W/ ZnCr Gold	Plated or Unplated Silver	Plated W/ ZnCr Gold	Plated or Unplated Silver	Plated W/ ZnCr Gold	W/ Grade 5 Bolt
1/4	55 in / lb (6.2 N•m)	72 in / lb (8.1 N•m)	86 in / lb (9.7 N•m)	112 in / lb (12.6 N•m)	121 in / lb (13.6 N•m)	157 in / lb (17.7 N•m)	61 in / lb (6.9 N•m)	86 in / lb (9.8 N•m)
5/16	115 in / lb (13 N•m)	149 in / lb (17 N•m)	178 in / lb (20 N•m)	229 in / lb (26 N•m)	250 in / lb (28 N•m)	325 in / lb (37 N•m)	125 in / lb (14 N•m)	176 in / lb (20 N•m)
3/8	17 ft / lb (23 N•m)	22 ft / lb (30 N•m)	26 ft / lb (35 N•m)	34 ft / lb (46 N•m)	37 ft / lb (50 N•m)	48 ft / lb (65 N•m)	19 ft / lb (26 N•m)	26 ft / lb (35 N•m)
7/16	27 ft / lb (37 N•m)	35 ft / lb (47 N•m)	42 ft / lb (57 N•m)	54 ft / lb (73 N•m)	59 ft / lb (80 N•m)	77 ft / lb (104 N•m)	30 ft / lb (41 N•m)	42 ft / lb (57 N•m)
1/2	42 ft / lb (57 N•m)	54 ft / lb (73 N•m)	64 ft / lb (87 N•m)	83 ft / lb (113 N•m)	91 ft / lb (123 N•m)	117 ft / lb (159 N•m)	45 ft / lb (61 N•m)	64 ft / lb (88 N•m)
9/16	60 ft / lb (81 N•m)	77 ft / lb (104 N•m)	92 ft / lb (125 N•m)	120 ft / lb (163 N•m)	130 ft / lb (176 N•m)	169 ft / lb (229 N•m)	65 ft / lb (88 N•m)	92 ft / lb (125 N•m)
5/8	83 ft / lb (112 N•m)	107 ft / lb (145 N•m)	128 ft / lb (174 N•m)	165 ft / lb (224 N•m)	180 ft / lb (244 N•m)	233 ft / lb (316 N•m)	90 ft / lb (122 N•m)	127 ft / lb (172 N•m)
3/4	146 ft / lb (198 N•m)	189 ft / lb (256 N•m)	226 ft / lb (306 N•m)	293 ft / lb (397 N•m)	319 ft / lb (432 N•m)	413 ft / lb (560 N•m)	160 ft / lb (217 N•m)	226 ft / lb (306 N•m)
7/8	142 ft / lb (193 N•m)	183 ft / lb (248 N•m)	365 ft / lb (495 N•m)	473 ft / lb (641 N•m)	515 ft / lb (698 N•m)	667 ft / lb (904 N•m)	258 ft / lb (350 N•m)	364 ft / lb (494 N•m)
1	213 ft / lb (289 N•m)	275 ft / lb (373 N•m)	547 ft / lb (742 N•m)	708 ft / lb (960 N•m)	773 ft / lb (1048 N•m)	1000 ft / lb (1356 N•m)	386 ft / lb (523 N•m)	545 ft / lb (739 N•m)

**This page intentionally
left blank**



Warranty

MANUFACTURER'S LIMITED WARRANTY

BLUE DIAMOND® ATTACHMENTS, a manufacturer of quality attachments, warrants new BLUE DIAMOND® ATTACHMENTS products and/or attachments at the time of delivery to the original purchaser, to be free from defects in material and workmanship when properly set up and operated in accordance with the recommendations set forth by BLUE DIAMOND® ATTACHMENTS, LLC.

BLUE DIAMOND® ATTACHMENTS liability for any defect with respect to accepted goods shall be limited to repairing the goods at a BLUE DIAMOND® ATTACHMENTS designated location or at an authorized dealer location, or replacing them, as BLUE DIAMOND® ATTACHMENTS shall elect. The above shall be in accordance with BLUE DIAMOND® ATTACHMENTS warranty adjustment policies. BLUE DIAMOND® ATTACHMENTS obligation shall terminate twelve (12) months for the Severe Duty Grapple Bucket after the delivery of the goods to original purchaser.

This warranty shall not apply to any machine or attachment which shall have been repaired or altered outside the BLUE DIAMOND® ATTACHMENTS factory or authorized BLUE DIAMOND® ATTACHMENTS dealership or in any way so as in BLUE DIAMOND® ATTACHMENTS judgment, to affect its stability or reliability, nor which has been subject to misuse, negligence or accident beyond the company recommended machine rated capacity.

WARRANTY CLAIM

To submit a warranty claim, a claim must be filed with BLUE DIAMOND® ATTACHMENTS before work is performed. The BLUE DIAMOND® PRODUCT SUPPORT TEAM will advise repairs and applicable parts exchanges. Tampering with the failed part may void the warranty. This warranty does not include freight or delivery charges incurred when returning machinery for servicing. Dealer mileage, service calls, and pickup/delivery charges are the customers' responsibility.

EXCLUSIONS OF WARRANTY

Except as otherwise expressly stated herein, BLUE DIAMOND® ATTACHMENTS makes no representation or warranty of any kind, expressed or implied, AND MAKES NO WARRANTY OF MERCHANTABILITY IN RESPECT TO ITS MACHINERY AND/OR ATTACHMENTS ARE FIT FOR ANY PARTICULAR PURPOSE. BLUE DIAMOND® ATTACHMENTS shall not be liable for incidental or consequential damages for any breach or warranty, including but not limited to inconvenience, rental of replacement equipment, loss of profits or other commercial loss. Upon purchase, the buyer assumes all liability for all personal injury and property resulting from the handling, possession, or use of the goods by the buyer.

No agent, employee, or representative of BLUE DIAMOND® ATTACHMENTS has any authority to bind BLUE DIAMOND® ATTACHMENTS to any affirmation, representation, or warranty concerning its machinery and/or attachments except as specifically set forth herein.

This warranty policy supersedes any previous documents.

NOTE: Blue Diamond® Attachments is a trademark of BLUE DIAMOND® ATTACHMENTS



QUALITY | DEPENDABILITY | INTEGRITY

Blue Diamond® Attachments
4512 Anderson Road, Knoxville, TN 37918
888-376-7027