

Severe Duty Series 3 Power Rake

Operation and Maintenance Manual



Register your
WARRANTY
within 30 days
of purchase



888-376-7027 | BlueDiamondAttachments.com



BD-092

Introduction: Owner Information

Thank you for your decision to purchase a Blue Diamond® Severe Duty Series 3 Power Rake. To ensure maximum performance of your equipment, it is mandatory that you thoroughly study the Operator's manual and follow the recommendations. Proper operation and maintenance are essential to maximize equipment life and prevent personal injury.

Operate and maintain this equipment in a safe manner and in accordance with all applicable local, state, and federal codes, regulations and /or laws. Follow all on-product labeling and instructions.

Make sure that all personnel have read this Operator's Manual and thoroughly understand safe and correct operating, installation and maintenance procedures.

Blue Diamond is continually working to improve its products. Blue Diamond reserves the right to make any improvements or changes as deemed practical and possible without incurring any responsibility or obligation to make any changes or additions to equipment sold previously.

Although great care has been taken to ensure the accuracy of this publication, Blue Diamond makes no warranty or guarantee of any kind, written or expressed, implied or otherwise with regard to the information contained within this manual. Blue Diamond assumes no responsibility for any errors that may appear in this manual and shall not be liable under any circumstances for incidental, consequential or punitive damages in connection with, or arising from the use of this manual.

Keep this manual available for frequent reference. All new operators or owners must review the manual before using the equipment and annually thereafter. Contact your Blue Diamond Attachments Dealer for assistance, information, or additional copies of the manual. Contact www.bluediamondattachments.com or call 888-376-7027 for a complete list of dealers in your area.

Serial Number Location:

Please record attachment information in the space provided for future reference.



Model Number: _____

Serial Number: _____

Dealer Name: _____

Dealer Number: _____

Date of Purchase: _____

The serial number plate is located on the right side of the frame above the rotor.

Always use your serial number when requesting information or when ordering parts.

NOTE: The directions left, right, front and rear, as mentioned throughout this manual, are as viewed from the operator's position.

Table of Contents

1. Introduction.....	4
1.1 Safety Decals	4
2. Safety	6-8
2.1 General Safety Information	6
2.2 Qualified Operations.....	6
2.3 Safety Guidelines.....	7
3. Operation	9-14
3.1 Attachment Inspection.....	9
3.2 Entering and Exiting the Prime Mover	11
3.3 Attachment Installation.....	11
3.4 Operating the Attachment	13
4. Maintenance	15-24
4.1 Service Schedule	15
4.2 Lubrication.....	16
4.3 Material Bar	18
4.4 Side Shields & Skid Plates	19
4.5 Gauge Wheels	19
4.6 Drive Chain.....	20
4.7 Rotor	22
4.8 Slip Clutch Maintenance and Settings	23
4.9 Cleaning the Attachment.....	24
5. Troubleshooting.....	25
6. Parts.....	25-40
6.1 Parts Breakdown Options	25
6.2 Hydraulic Main Body.....	26
6.3 Driveline Hydraulic	27
6.4 Rotor Options.....	28
6.5 3-Point Cat 2 Mount	29
6.6 Hydraulic Heavy Skid Steer Mount.....	29
6.7 Chain Case PTO	30
6.8 Chain Case Hydraulic	32
6.9 Chain Tensioner	34
6.10 Bearing Housing, 2 Bolt 232045 (Old Style).....	35
6.11 Bearing Housing, 2 Bolt 232057 (New Style)	35
6.12 Bearing Housing, 4 Bolt 232050	35
6.13 Side Shield Options.....	36
6.14 Gauge Wheel Options	37
6.15 Material Bar Options.....	38
7. Specifications.....	41
7.1 Attachment Specifications.....	41
7.2 Torque Specifications	42
8. Warranty	43

1. Introduction

1.1 Safety Decals

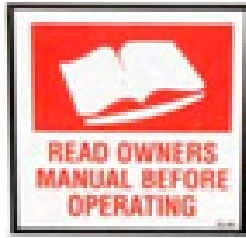

WARNING! Read Owner's Manual



WARNING! Keep Hands Away



ATTENTION! Grease all Fittings

2. Safety

2.1 General Safety Information



This **SAFETY ALERT SYMBOL** identifies important safety messages on the equipment and in the owner's manual. When you see this symbol, be alert to the possibility of personal injury and carefully read the message that follows.



The signal word **IMPORTANT** identifies procedures which must be followed to avoid damage to the machine.



The signal word **DANGER** on the machine and in the manuals indicates a hazardous situation which, if not avoided, will result in death or serious injury.



The signal word **WARNING** on the machine and in the manuals indicates a potentially hazardous situation which, if not avoided, could result in death or serious injury.



The signal word **CAUTION** on the machine and in the manuals indicates a potentially hazardous situation which, if not avoided, may result in minor or moderate injury. It may also be used to alert against unsafe practices.

2.2 Qualified Operators

Safe Operation Needs a Qualified Operator



AVOID SERIOUS INJURY OR DEATH

Operators must receive instructions before operating the machine. Untrained operators can cause serious injury or death.

For an operator to be qualified, he or she must not use drugs or alcoholic drinks which impair alertness or coordination while working. An operator who is taking prescription drugs must get medical advice to determine if he or she can safely operate a machine and the equipment.

For an operator to be qualified, he or she must have read and understood the instructions of this manual, he or she must make adequate preparation for the proper use of the machine, and he or she must hold a driving license.

In case of doubt regarding the use of the machine and/or the interpretation of this manual, the operator must contact either their dealer or Blue Diamond.

Operator Training

- Check the rules and regulations at your location. The rules may include an employer's work safety requirements. Regulations may apply to local driving requirements or use of a Slow Moving Vehicle (SMV) emblem. Regulations may identify a hazard such as a utility line.
- The new operator must start in an area without bystanders and use all the controls until he or she can operate the machine safely under all conditions of the work area.

2. Safety

2.3 Safety Guidelines

Operating Safety

- Read and follow instructions in this manual and the machine's Operator's Manual before operating.
- This equipment is dangerous to persons unfamiliar with its operation.
- Check for overhead and / or underground lines before operating equipment (if applicable).
- In addition to the design and configuration of equipment, hazard control and accident prevention are dependent upon the awareness, concern, prudence and proper training of personnel involved in the operation, transport, maintenance and storage of equipment.
- Check that the attachment is securely fastened to the machine.
- Make sure all the machine controls are in NEUTRAL before starting the machine.
- Operate the equipment only from the operator's position.
- Operate the equipment according to the Operator's Manual.
- When learning to operate the equipment, do it at a slow rate in an area clear of bystanders.
- DO NOT permit personnel to be in the work area when operating the equipment.
- The equipment must be used ONLY on approved machines.
- DO NOT modify the equipment in any way. Unauthorized modification may impair the function and / or safety and could affect the life of the equipment. Warranty may also be affected or voided.
- DO NOT make any adjustments or repairs on the equipment while the machine is running.
- Keep shields and guards in place. Replace if damaged.
- DO NOT operate equipment in poor visibility conditions such as fog, darkness, or any conditions that limit clear visibility less than 300 feet (100 m) in front of and to the sides of the equipment.
- DO NOT operate in a work area that has not been inspected for foreign debris and obstacles.
- Remove any foreign objects and clearly mark any objects that cannot be removed.
- Wear safety glasses, gloves, hearing protection and other protective clothing when required.

Machine Requirements and Capabilities

- The machine's operator's cab should be equipped with a thermoplastic polycarbonate or similar material front window, and similar protection on the sides of the operator's cab before operating the equipment.
- Do Not exceed 4000 PSI (275.8 bar) operating pressure.
- Use caution on slopes and near banks and ditches to prevent overturn.

2. Safety

2.3 Safety Guidelines Cont'd

Fire Prevention Safety

- Flammable debris (leaves, grass, etc.) must be removed regularly. If flammable debris is allowed to accumulate, it can cause a fire hazard. Clean often to avoid this accumulation.
- All fuels, most lubricants and some coolant mixtures are flammable. Flammable fluids that are leaking or spilled onto hot surfaces or onto electrical components can cause a fire.

Transporting Safety

- Comply with state and local laws governing highway safety and movement of machinery on public roads.
- Check local laws for all highway lighting and marking requirements.
- Never allow riders on either machine or equipment.
- If transporting the attachment on a truck or trailer, make sure it is properly secured to the transport vehicle.

Hydraulic System

- Check hydraulic tubes, hoses and fittings for damage and leakage. Never use open flame or bare skin to check for leaks. Hydraulic tubes and hoses must be properly routed and have adequate support and secure clamps. Tighten or replace any parts that show leakage.
- Always clean fluid spills. Do not use gasoline or diesel fuel for cleaning parts. Use commercial nonflammable solvents.

3. Operation

3.1 Attachment Inspection

Pre-Operation Inspection

Before operating the power rake for the first time and each time thereafter, use the following list as a guideline during equipment inspection.



WARNING



AVOID SERIOUS INJURY OR DEATH

- Disengage machine's auxiliary hydraulics, engage the machine's parking brake, stop the engine and make sure all rotating components are completely stopped before connecting, disconnecting, adjusting or cleaning equipment.
- Always keep shields and all guards in place when using the equipment.
- Disengage machine's auxiliary hydraulics for road travel.
- Keep hands, feet and clothing away from rotating parts.

- Lubricate the attachment per the schedule outlined in the Maintenance Section. See "Service Schedule" on page 14.
- Check the power rake mounting frame for damage or cracks.
- Check that all shields and guards are in place.
- Check for loose bolts and tighten them if necessary.
- Check all welds on the attachment for wear and damage each time the attachment is removed from the machine.
- Check for damaged or missing safety decals. Replace if necessary.

- Inspect the machine's mounting frame. (See the machine's Operator's Manual for inspecting the mounting frame). Replace any parts that are damaged, bent or missing. Keep all fasteners tight. Look for cracked welds.



WARNING



Leaking fluids under pressure can enter the skin and cause serious injury or death. Immediate medical attention is required. Wear goggles. Use cardboard to check for leaks.

- Check condition of all hydraulic components for leaks. Repair as required.

NOTE: Do not operate with hydraulic leaks.

- Verify that the power rake is properly connected to the machine.

3. Operation

3.1 Attachment Inspection Cont'd

Daily Inspection

NOTE: Inspect the attachment by performing a walk around daily before and after use. Use the following inspection checklist as a guideline.

Check the following items every 10 hours of operation:

- Verify that the power rake is properly connected to the machine.
- Check that all shields and guards are in place.
- Check hydraulic lines, connections and fittings for hydraulic oil leaks. Repair or replace damaged parts if necessary.
- Check the power rake mounting hardware for wear or damage. Inspect the pins and mount (on the attachment) for wear or damage. Repair or replace damaged parts if necessary.

Weekly Inspection

Check the following items every 40 hours of operation:

- Check all bolts for tightness:
 - 3/8" bolts to 50 ft/lb (67.5 N•m) torque
 - 1/2" bolts to 100 ft/lb (135 N•m) torque
 - 3/4" bolts to 223 ft/lb (302 N•m) torque
- Inspect the main frame for cracks, bends, or damage.

Monthly Inspection

- Inspect the main frame and wedge for cracks, bends, or excessive wear.
- Check that cylinders protection cover is in good condition and truly attached.
- Check that all bolts are tight.
- Check for damaged or missing decals. Replace if necessary.
- Check for damaged or leaking hydraulic hoses or fittings. Replace if necessary.
- Clean all debris, sticks, leaves, grass and flammable material from deck area and under covers.
- Lubricate as required.



WARNING



AVOID SERIOUS INJURY OR DEATH

Before servicing the attachment:

- Always park on a flat level surface.
- Lower lift arms and place attachment flat on the ground.
- Place all controls in **NEUTRAL**.
- Engage the park brake.
- Stop the engine and remove the key.
- Wait for all moving parts to stop.

**SEE MACHINE'S OPERATOR'S MANUAL FOR
ADDITIONAL INFORMATION.**

3. Operation

3.2 Entering and Exiting the Prime Mover



See the machine's Operator's Manual for detailed information on operating the loader.

Entering the Operator's Position

Use the attachment safety treads, handles and steps (on the machine) to enter the operator's position.

When in the operator's position, lower safety seat bar, fasten the seat belt, start the engine and release the parking brake.

Leaving the Operator's Position



AVOID SERIOUS INJURY OR DEATH

Before servicing the attachment:

- Always park on a flat level surface.
- Lower lift arms and place attachment flat on the ground.
- Place all controls in NEUTRAL.
- Engage the park brake.
- Stop the engine and remove the key.
- Wait for all moving parts to stop.

SEE MACHINE'S OPERATOR'S MANUAL FOR ADDITIONAL INFORMATION.

Park the machine / attachment on a flat level surface. Place all controls in neutral, engage the park brake and stop the engine. Leave the operator's position.

3.3 Attachment Installation

Connecting Attachment to the Machine



CRUSH HAZARD

- Before moving the machine, look in all directions and make sure no bystanders, especially small children are in the work area. Do not allow anyone between the machine and attachment when approaching the attachment for connecting.
- Keep fingers and hands out of pinch points when connecting and disconnecting the attachment.

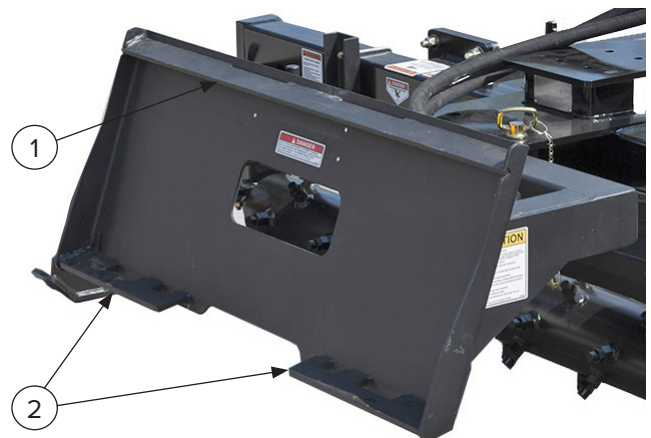

Figure 1

Inspect the power rake's mounting flange (Item 1) and wedge mounts (Item 2) and all welds on the power rake for wear or damage each time the power rake is removed from the machine [Figure 1].

(See the machine's Operator's Manual for inspecting the mounting frame).

3. Operation

Connecting Attachment to the Machine Cont'd

Slowly tilt the machine's mounting plate back until the attachment mounting frame fully contacts the front of the machine's mounting plate.

Leave the Operator's position. See "Leaving the Operator's Position" on page 10.



WARNING



AVOID SERIOUS INJURY OR DEATH

The locking pins / wedges must extend through the holes in the attachment mounting frame. Failure to secure locking pins / wedges can allow attachment to come off.

**SEE MACHINE'S OPERATOR'S MANUAL FOR
ADDITIONAL INFORMATION.**

Engage attachment locking levers / wedges (See the machine's Operator's Manual for detailed information).

Connecting Hydraulic Hoses



IMPORTANT



Thoroughly clean the quick couplers before making connections. Dirt can quickly damage the hydraulic system.

Remove dirt or debris from the male and female couplers. Visually inspect the couplers for corroding, cracking, damage, or excessive wear. Replace as needed.

Connect the attachment hydraulic hoses to the machine. Pull on each hose to verify full connection is made.

Disconnecting Hydraulic Hoses



WARNING



AVOID SERIOUS INJURY OR DEATH

Hydraulic fluid, tubes, fittings, and quick couplers can get hot during operation. Be careful when connecting and disconnecting hydraulic hoses.

Relieve auxiliary hydraulic pressure. (See the machine's Operator's Manual for correct procedure.)

Disconnect attachment hydraulic hoses from the machine.

Disconnecting Attachment From the Machine

Relieve auxiliary hydraulic pressure. (See the machine's Operator's Manual for correct procedure.)

Park the machine and attachment on a flat level surface. Lower the attachment flat on the ground.

Leave the operator's position. See "Leaving The Operator's Position" on page 10.

Disconnect attachment hydraulic hoses from the machine.

Disengage locking pins / wedges. (See the machine's Operator's Manual for correct procedure.)

Enter the operator's position. See "Entering The Operator's Position" on page 10.

Slowly tilt the machine's mounting plate forward until the attachment mounting frame is free from the machine's mounting plate.

Drive the machine slowly backward, away from the attachment.

3. Operation

3.4 Operating the Attachment

Machine Requirements

The machine must be equipped with a case drain.

Skid Steer Requirements

FLOW	30 – 40 GPM
MAX PRESSURE	4000 PSI

Clearing Work Area



- **DO NOT** operate in a work area that has not been cleared of foreign debris and obstacles.
- Rocks, metal, construction debris, and other objects can damage the power rake.
- Clearly mark any objects that cannot be removed.
- If an area contains tall grass, clear cut the area first, either by mowing or tilling the ground.

Initial Setup

NOTE: The ground conditions will determine the best settings for the power rake. Choose the mode that's right for the application.

Tilling Mode

Removing the side shields converts the power rake into tilling mode.

Removing the side shield and opening up the material bar hold back rubber shield will allow for material flow when in tilling mode.

NOTE: When in tilling mode and in hard pack soil gravel, adjust the angle to 10 or 20 degrees for aggressive sawtooth action.

NOTE: Adjust the angle to 10 or 20 degrees for material windrowing (such as rocks and debris).

Landscaping Mode

For landscaping, side shields are installed and material bar set to desired gap.

NOTE: The side shields contain the material in front of the rotor while the clean material passes between rotor and material bar rubber shield.

Gauge Wheels

Adjust the gauge wheels if necessary. See page 18.

Skid Plates

If equipped with skid plates adjust if necessary. See page 18.

3. Operation

Starting the Power Rake



When operating or transporting, run the power rake on the gauge wheels. This is done by lifting boom and tilting lift arms forward running gauge wheels on the ground.



DO NOT exceed 4000 PSI (275.8 bar) operating pressure. Serious damage can result.

Install the power rake onto the machine.

Move to the operator's position, lower seat bar, start the engine and release the parking brake.

Raise the power rake slightly off the ground.

With the machine's engine RPM just above idle, engage the auxiliary hydraulic flow (see the machine's operator's manual) to the power rake.

Slowly raise the machine's engine RPM to the correct and desired speed.

Slowly lower the power rake to the ground and begin forward travel.

NOTE: DO NOT SLAM INTO THE GROUND.

Damage may occur to the power rake and machine.

NOTE: Recommended ground speed is between 2 to 6 mph (3 to 9 km/h). In severe duty applications, reduce ground speed.



WARNING



AVOID SERIOUS INJURY OR DEATH

Before servicing the attachment:

- Always park on a flat level surface.
- Lower lift arms and place attachment flat on the ground.
- Place all controls in NEUTRAL.
- Engage the park brake.
- Stop the engine and remove the key.
- Wait for all moving parts to stop.

SEE MACHINE'S OPERATOR'S MANUAL FOR ADDITIONAL INFORMATION.



WARNING



Debris such as rope, wire, roots, plastic, etc. may wrap around rotor. **STOP IMMEDIATELY** and remove foreign material. Spinning of rotor and throwing of material may cause harm to operators or bystanders!

Stopping the Power Rake

Position the power rake slightly off the ground.

Set the machine's engine RPM to an idle, allow the power rake to slow down, disengage the auxiliary hydraulic flow (see the machine's operator manual) to the power rake.

4.Maintenance

4.1 Service Schedule

DESCRIPTION	SERVICE PROCEDURES			
	Check	Clean	Lube	Change
Daily Maintenance (or every 8 hours)				
Hydraulic Fittings	•			
Hydraulic Hoses	•			
Hydraulic Motor	•	•		
Rotor Teeth (wear, damage, and loosening)	•	•		
All Hardware	•			
Power Rake Frame	•	•		
Weekly Maintenance (or every 40 hours)				
Wheel Axles			•	
Gauge Wheel Spindles			•	
Rotor Bearings			•	
Angle Pivot Pins			•	
Rotor Teeth (wear, damage, and loosening)	•			
Rotor (cracks or excessive wear)	•			
All Hardware	•			
Chain Case Oil (80-90W) (if used)	•			
Monthly Maintenance				
Drive Chain	•		•	
Skid Plates	•			
Rotor Teeth (wear, damage, and loosening)	•			
Rotor (cracks or excessive wear)	•			
All Hardware	•			
250 Hour Maintenance				
Chain Case Oil (80-90W) (if used)				•

4.Maintenance

4.2 Lubrication



DANGER



AVOID SERIOUS INJURY OR DEATH

Before servicing the Power Rake:

- Lower the machine's lift arms and place the power rake on flat, level surface.
- Engage parking brake, stop engine, remove the key and exit the machine.
- Disconnect attachment hydraulic hoses.



WARNING



AVOID SERIOUS INJURY OR DEATH

DO NOT work under the machine lift arms in the raised position without the lift arms being properly locked or blocked (see machine operator manual for more information).



IMPORTANT



Fluid such as hydraulic fluid, coolants, grease, etc. must be disposed of in an environmentally safe manner. Some regulations require that certain spills and leaks on the ground must be cleaned in a specific manner. See local, state, and federal regulations for the correct disposal.

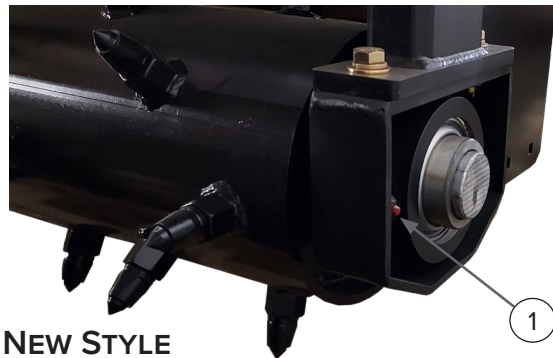

NEW STYLE

Figure 2-2

Apply grease to the bearing zerks on each end of the rotor (Item 1) [Figure 2-1 and Figure 2-2].

NOTE: If power rake has old style bearing, Blue Diamond recommends installing grease zerk plugs in the rotor bearings in between services.



Figure 3

Apply 2 – 3 pumps of grease to the grease zerk (Item 1) [Figure 3] on the wheel axles.



OLD STYLE

Figure 2-1

4.Maintenance

4.2 Lubrication Cont'd



Figure 4

Apply 2-3 pumps of grease to the grease zerk (Item 1) [Figure 4] on the gauge wheel spindles.



Figure 5

Apply a coat of grease to the inside upper pivot plate (Item 1) [Figure 5] and lower pivot plate (Item 2) [Figure 5].

Chain Case Lubrication

NOTE: Chain comes lubricated with a spray lubricant.



Chain must be kept lubricated. Alternatives to the oil bath include any viscosity lubricant applied using the appropriate method for each lubricant.
DO NOT MIX LUBRICANTS.

Oil Bath Option

NOTE: The chain case oil should be changed after the first 100 hours or 30 days of operation and 250 hours thereafter.

NOTE: To check the chain case oil, park the power rake on a smooth level surface. Remove the bolt (Item 1) [Figure 6]. If no oil present, fill the chain case with 80/ 90W oil until oil leaks out the bolt hole. Install bolt.

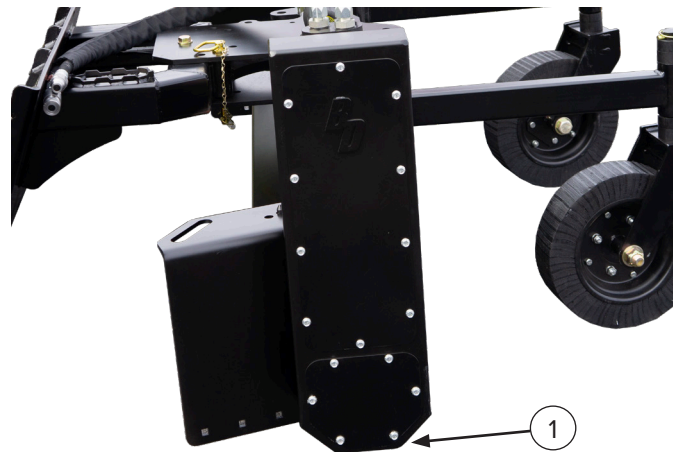

Figure 6

Change Chain Case Oil

Place a pan below the chain case, remove the bolts on the lower cover (Item 1) and remove lower cover. Drain the oil.

Remove all oil from gearbox, install new gasket and lower cover with bolts (Item 1) previously removed.

Fill chain case with 80/90W oil to bolt (Item 1) level. Reinstall bolt.

4. Maintenance

4.3 Material Bar

Material Bar Adjustment / Replacement



DANGER



AVOID SERIOUS INJURY OR DEATH

Before servicing the Power Rake:

- Lower the machine's lift arms and place the power rake on flat, level surface.
- Engage parking brake, stop engine, remove the key and exit the machine.
- Disconnect attachment hydraulic hoses.

Material Bar Adjustment

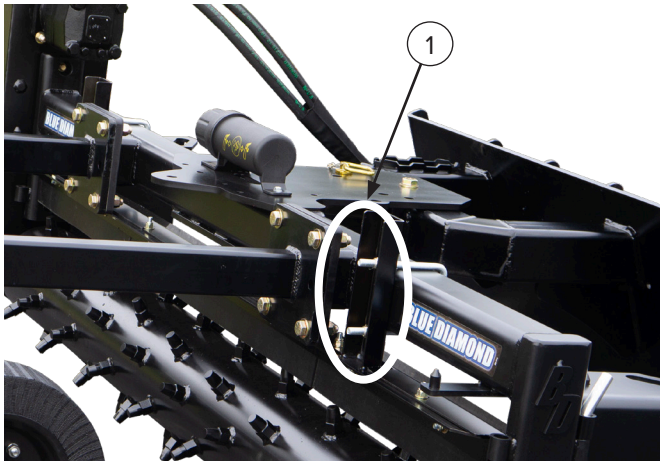

Figure 8

To adjust the material bar, loosen both nuts (Item 1) [Figure 8] (both sides) and adjust either up or down.

Adjusting the material bar up will let more material pass through the power rake and adjusting the material bar down will hold back material like rocks and debris.

NOTE: When adjusting the material bar, make sure the material bar is level.

NOTE: A normal setting is a 1 inch (25 mm) gap between the rotor teeth and the material bar.

A wider opening will allow more dirt and rock to pass through. "Soil Conditioning" allowing wet soil to dry for final raking. For finer raking, adjust the material bar down. Be careful not to let rotor teeth contact the material bar.

Material Bar Removal / Installation

Remove the nuts, washers and U-bolts (Item 1) [Figure 8] from the material bar (both sides).
Remove material bar.

Align material bar mounts (both sides) with the holes in the power rakes frame.

Install U-bolts, washers and nuts.

NOTE: Verify that the material bar is level and adjusted to the desired gap before tightening bolts.

Material Bar Rubber Shield Replacement

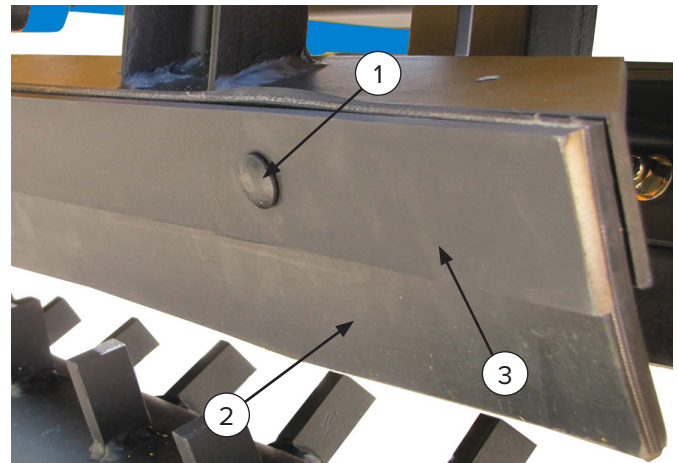

Figure 9

Remove material bar. See material bar removal / installation on page 17.

Remove the nuts and bolts (Item 1) [Figure 9].

Remove the rubber shield (Item 2) and the rubber shield mounting strip (Item 3) [Figure 9].

Align the rubber shield and mounting strip onto the material bar.

Install bolts, nuts and tighten.

Install material bar. See material bar removal / installation on page 17.

4. Maintenance

4.4 Side Shields & Skid Plates

Side Shield and Skid Plate Removal/Installation

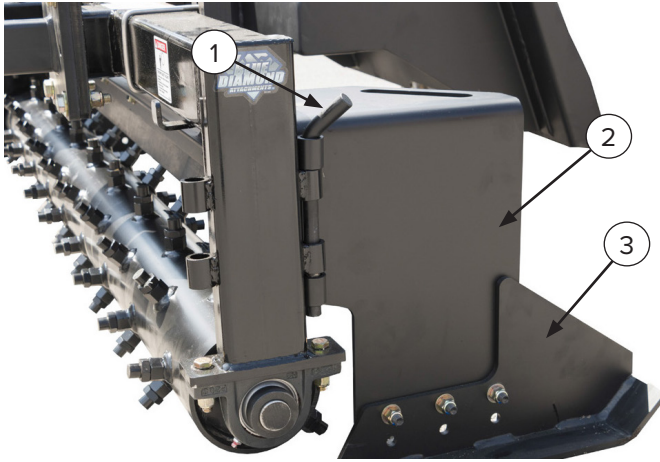

Figure 10

Remove the pin (Item 1) and remove the side shield (Item 2) and skid plate (Item 3) [Figure 10] on both sides.

Skid Plate Adjustment

Remove the three nuts and bolts (Item 4) [Figure 10] then remove the skid plate (Item 2) [Figure 10].

Align the desired skid plate holes with the side shield (Item 3) [Figure 10] holes, install the bolts and nuts, and tighten.

4.5 Gauge Wheels

Gauge Wheel Adjustment

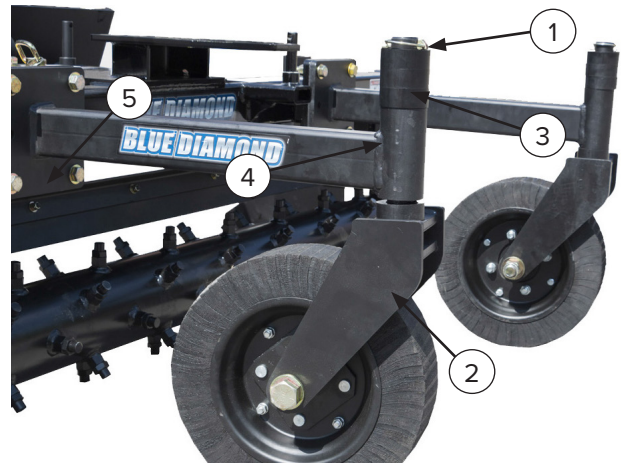

Figure 11

Remove the retaining pin (Item 1) and lower the spindle (Item 2). Relocate spacers as desired above or below the spindle mount arm (Item 4) [Figure 11].

Install the spindle and install the retaining pin.

NOTE: The gauge wheel can also be adjusted up / down at the spindle mount arm (Item 5) [Figure 13].

Remove the four bolts, washers, and nuts. Position the spindle mount arm as desired. Install and tighten the four bolts, washers, and nuts.

Repeat procedure on the other main spindle mount.

4. Maintenance

4.6 Drive Chain

Chain Tensioner

NOTE: The drive chain should be inspected monthly. New chain has a tendency to stretch.

Chain Tensioner Adjustment



CAUTION



Over tightening chain tensioner may damage or cause excessive wear to chain, sprockets, and tensioner rollers.

1. Raise and support the attachment so the rotor is free.
2. Remove the upper access cover (Item 1) [Figure 13] to perform inspection. Use inspection chart below.
3. Tighten nut (Item 3) [Figure 13] until snug, back off 1/2 - 3/4 of a turn. The tensioner arms (Item 2) [Figure 13] should swing freely.

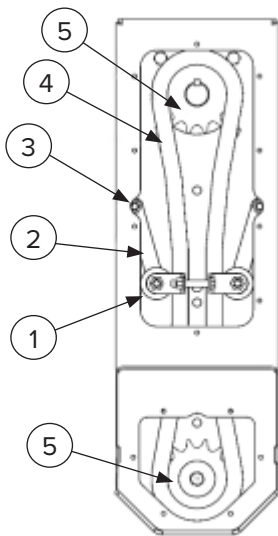

Figure 13

4. Adjust nut (Item 6) and bolt (Item 7) [Figure 14].

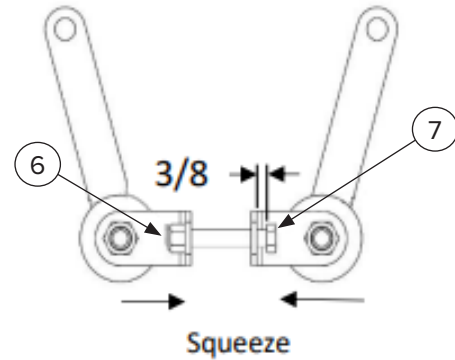

Figure 14

5. There should be approximately a 3/8" clearance under bolt head when tensioner brackets are squeezed together.
6. By hand, spin the rotor and observe that the chain has some slack. On hydraulic models, connect the hoses together to allow fluid to circulate so the rotor can spin.
7. Reinstall the upper access cover. Install fasteners and tighten to recommended torque. See Torque Specifications chart on page 42.

4.Maintenance

4.6 Drive Chain Cont'd

Inspection

	ITEMS
✓	Check for loose, missing, or damaged hardware.
✓	Check for any cracks.
✓	Inspect for worn tensioner rollers (Item 1) [Figure 13].
✓	Inspect the chain (Item 4) and sprockets (Item 5) [Figure 13] for excessive wear.

Chain Removal

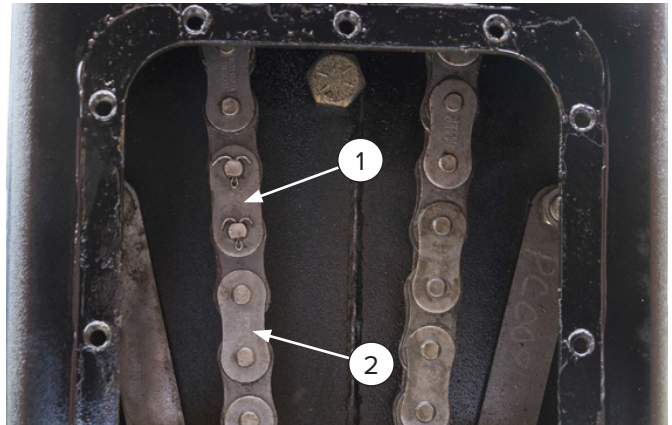

Figure 15

NOTE: Chain replacement requires draining of any chain case oil. See Oil Bath Option on page 16.

Remove the chain case top and bottom covers. Remove the chain tensioner bolt.

Remove the master link (Item 1) and remove the chain (Item 2) [Figure 15]. Install new chain and master link.

Re-install the chain tensioner bolt and check for proper tension. Re-install bottom and top covers.

Fill chain case with oil if desired. See “Change Chain Case Oil” on page 16.

4.Maintenance

4.7 Rotor

Rotor Removal / Installation



WARNING



AVOID SERIOUS INJURY OR DEATH

Securely block up the attachment before working underneath.

1. Remove the side shields. See side shield and skid plates on page 18.
2. Remove the upper chain case cover.
3. Drain the chain case oil. See Change Chain Case Oil on page 16.
4. Remove the lower chain case cover.
5. Remove the drive chain. See Chain Removal on page 20.
6. Remove the chain master link and remove the chain.
7. Loosen the two set screws on the sprocket and remove the sprocket and key.



WARNING



AVOID SERIOUS INJURY OR DEATH

Secure the rotor with a lifting device before removing bearing mount bolts.

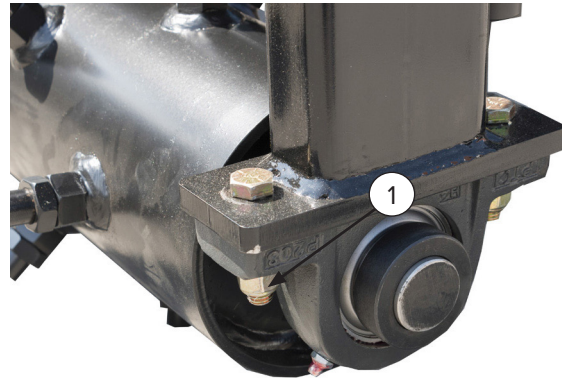

Figure 16

8. Remove the two bearing mount bolts (Item 1) [Figure 16].

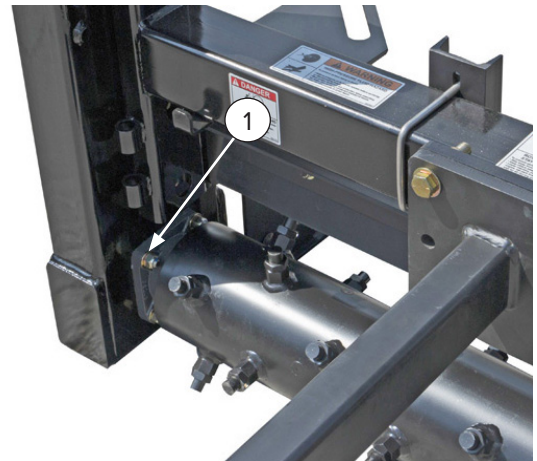

Figure 17

9. Remove the bearing mount bolts (Item 1) [Figure 17].
10. Slide the rotor back away from the gear box until the rotor is free.
11. Remove both bearings from the rotor shaft.
12. To install the rotor, reverse the procedures.

4.Maintenance

4.7 Rotor Cont'd

Replaceable Rotor Teeth



Figure 18

Remove the damaged tooth by turning counterclockwise. Install the new tooth by turning clockwise.

Fixed Rotor Teeth

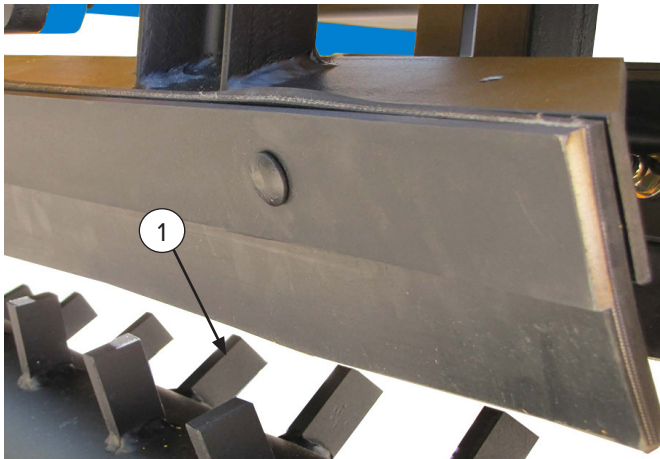

Figure 19

The fixed tooth rotor (Item 1) [Figure 19] is also offered for the power rake.

NOTE: If a tooth is damaged and needs to be replaced, cut and remove the damaged tooth and weld on the new tooth.

4.8 Slip Clutch Maintenance and Settings

When delivered from the factory, the slip clutch is loose. The clutch will need to be set to suit the specific application.

Slip Clutches need to be set if one of the following occurs

- The clutch is new
- The clutch has been repaired (including replacing the friction discs).
- The clutch is slipping in work (clutch getting hot, burning out friction discs).
- The clutch has been freed up after a period of storage (see “How to Free up Clutch” on page 23).

This is achieved by tensioning the clutch springs to their recommended compressed length of no more than 1". This distance is measured from the clutch plate to end of spring [Figure 20].

 **WARNING** 

Compressing the springs beyond these lengths will cause damage to the clutch and drive line.



Figure 20

4. Maintenance

4.8 Slip Clutch Maintenance and Settings Cont'd

How to Set Clutch:

The setting on the clutch is dependent on many variables - the work, the size of the tractor, and the size of the power rake. It is best to set up each clutch individually if possible. The aim is to start with a loose clutch and tighten it up to the exact point where it stops slipping in normal work. If set in this way, the clutch will slip if any load exceeds this point, protecting both the power rake and the tractor. It is best to set up the clutch with the power rake on the tractor and in conditions which approximate to the normal work desired.

The bolts which go through the springs and hold tension on the clutch determine the point at which the clutch slips. These must all be set evenly, either by measuring spring length or counting the number of turns the nut has been tightened. The clutch must be quite loose initially to ensure it will slip. Slipping can be identified by the clutch getting very hot. (The clutch will always be quite warm in work as the gearbox gets warm). Run the power rake for a short distance (5-10 ft) in work and check the clutch slips. Then tighten each tension bolt up a turn (more if the clutch was very loose) evenly and run a short distance again. Keep repeating this procedure until the clutch is not slipping - it should only take a few steps.

As you get to the point at which you think it is not slipping, tighten the tension bolts on quarter to half a turn instead of a full turn. Continue to operate the power rake, checking the clutch regularly; you will soon get an idea of how the clutch is performing. You may want to adjust it for varying conditions. If the clutch is too loose it will slip, wearing out the friction discs, getting hot and possibly damaging the clutch pressure surfaces as well. If the clutch is too tight it will fail to protect the tractor and power rake.

How to Free up the Clutch after a Period of Storage:

The slip clutch can seize if left for long periods without use. The best way to free up a slip clutch is to loosen all the bolts that hold the spring tension on the friction plates (so they are quite loose), then operate power rake with rotor engaging the ground for 30 - 60 sections verifying clutch is slipping. If clutch does not slip it will need to be disassembled and inspected for damage.

4.9 Cleaning the Attachment



DANGER



AVOID SERIOUS INJURY OR DEATH

Before servicing the Power Rake:

- Lower the machine's lift arms and place the power rake on flat, level surface.
- Engage parking brake, stop engine, remove the key, and exit the machine.
- Disconnect attachment hydraulic hoses.



WARNING



AVOID SERIOUS INJURY OR DEATH

Securely block up the attachment before working underneath.



WARNING



ROTOR WRAPPING

Debris such as rope, wire, roots, plastic, etc. may wrap around rotor. **STOP IMMEDIATELY** and remove foreign material. Spinning of rotor and throwing of material may cause harm to operator or bystanders!



IMPORTANT



Rotor wrapping may cause damage to bearings or bearing seals by jamming or cutting causing premature wear and damage.

5. Troubleshooting

PROBLEM	CAUSE	SOLUTION
Power rake vibrating	Debris build up between rotor and frame.	Remove debris.
	Faulty rotor bearing.	Replace bearing.
	Debris build up between rotor and frame.	Remove debris.
Rotor not turning.	Broken chain.	Replace chain.
	Sheared key in sprocket or rotor.	Replace key.
	Bad hydraulic hose connection.	Check hydraulic hose connections.
	Obstruction between rotor and frame.	Remove debris.
	Damaged motor shaft or seized motor.	Contact your dealer or Blue Diamond® Attachments Service Department.
	Faulty hydraulic coupler.	Replace hydraulic coupler.
Low pressure at startup / rotor turning slowly	Hydraulics not engaged.	Engage hydraulics.
	Hydraulic couplers are reversed.	Reverse male and female. Check for correct pressure.
	Faulty relief valve on power rake or machine.	Contact your dealer or Blue Diamond® Attachments Service Department.
Noise in chain case	Debris build up between rotor and frame.	Remove debris.
	Chain and sprockets worn.	Replace chain and sprockets.
	Broken or stretched chain tensioner spring.	Replace spring.
Chain case leaking.	Idler worn.	Replace idler.
	Faulty seal.	Remove cover and replace seal.
Gauge wheels do not turn.	Axle bolt too tight.	Loosen axle bolt.
	Object lodged between wheel and saddle assembly.	Remove object.
Gauge wheel wobbles.	Not enough down pressure.	Increase down pressure.
	Arms not positioned correctly.	Re-position arms. Adjust arm holder/plate down.
Angle will not hold position.	Faulty manifold.	Contact Blue Diamond® Product Support.
	Faulty solenoid.	Repair or replace solenoid.
Rocks are being left behind.	Material bar out of adjustment.	Adjust material bar.
	Material bar rubber is worn.	Replace material bar rubber.
Rocks are flowing out from front shields.	Over capacity.	Install optional skid plate.
		Reduce travel speed.
		Reduce engine speed.
Side shield allowing material out and leaving ridges.	Over capacity.	Install optional skid plate.
Side shields are bending.	Over capacity.	Install optional skid plate.
Material bar keeps going out of adjustment.	Slider plate is bent.	Replace slider plate.

6. Parts

6.1 Parts Breakdown Options

HYDRAULIC MAIN
BODY PG 26

CHAIN CASE
PG 30

GAUGE WHEEL
OPTIONS PG 37

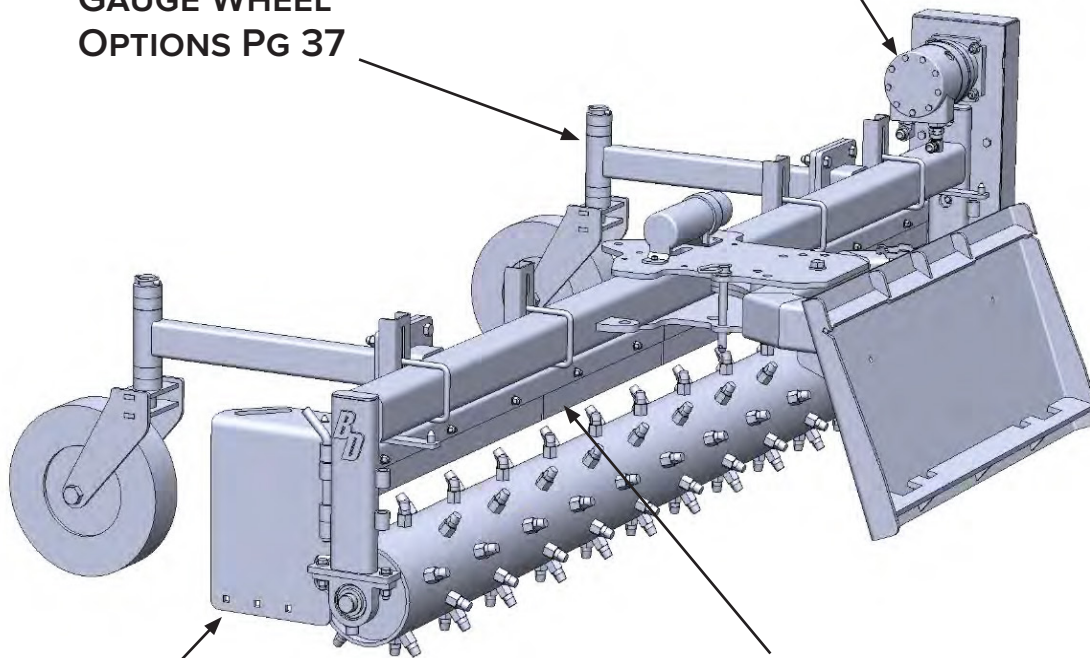

MATERIAL BAR
OPTIONS PG 38

SIDE SHIELDS
OPTIONS PG 36

6. Parts

6.2 Hydraulic Main Body

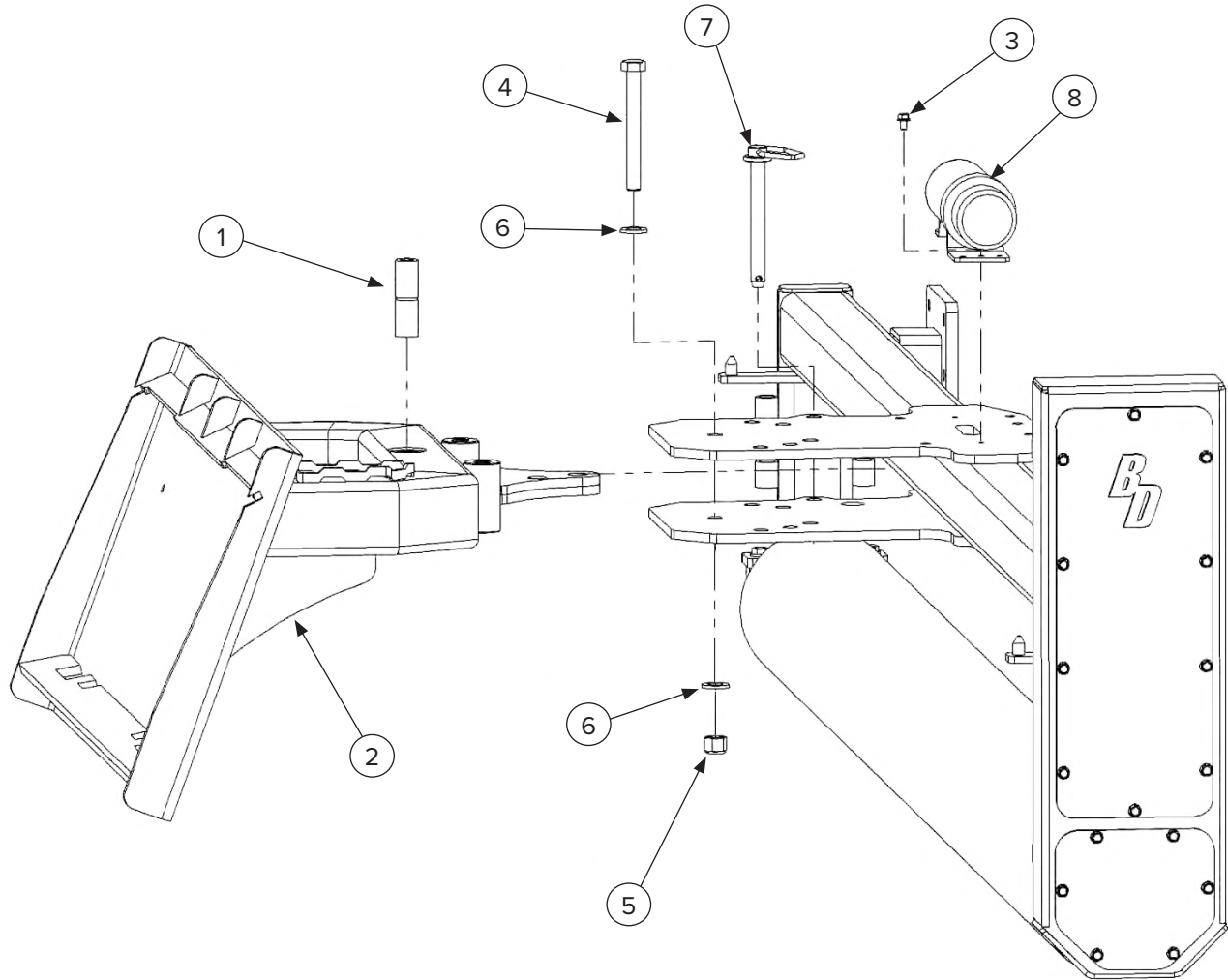

ITEM	PART NUMBER	DESCRIPTION	QTY
1	232220	Pivot Bushing, 3/4"	1
2	232318	Mount Assembly, Skid Steer, Heavy	1
3	232222	Bolt, 5/16"-18 X 1/2" Anti Vibe	2
4	232223	Bolt, 3/4"-10 X 6-1/2" HHCS Gr8	1
5	232224	Nut, 3/4"-10 Nyloc Gr8	1
6	232225	Washer, 3/4" X 1.469" SAE Gr8	2
7	232226	Pin, Drawbar 3/4" X 6-1/4"	1
8	216402	Manual Canister	1

6. Parts

6.3 Driveline Hydraulic

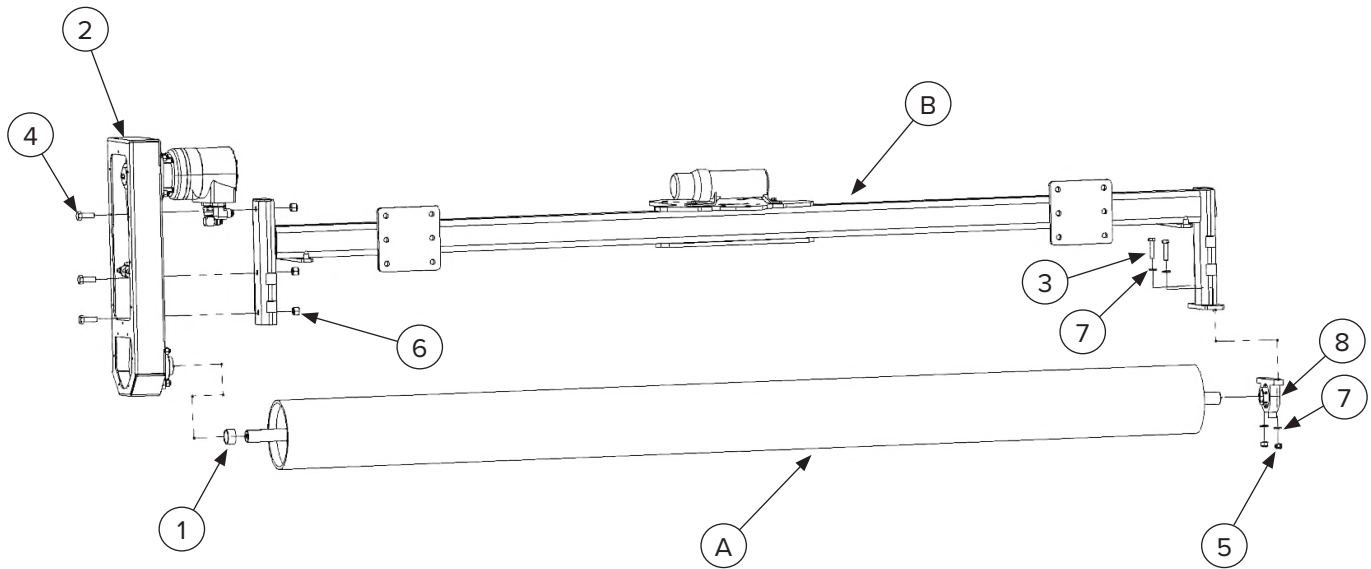

ITEM	PART NUMBER	DESCRIPTION	QTY
1	232024	Spacer, 1-1/2" X 1"	1
2	232319	Chain Case, HYD	1
3	232231	Bolt, 1/2"-13 X 2-1/4" HHCS Gr8	2
4	232232	Bolt, 5/8"-11 X 1-3/4" HHCS Gr8	3
5	232233	Nut, 1/2"-13 Nyloc Gr8	2
6	232294	Nut, 5/8"-11 Nyloc Gr8	3
7	232234	Washer, 1/2", SAE Gr8	4
8	232057	Bearing Housing Assembly, 2 Bolt	1

MODEL	ITEM A: ROTOR	ITEM B: FRAME	
		PART NUMBER	DESCRIPTION
7-Foot	See Rotor Options Page 28	232320	Main Frame, 7 feet
8-Foot		232316	Main Frame, 8 feet
10-Foot		232317	Main Frame, 10 feet

6. Parts

6.4 Rotor Options

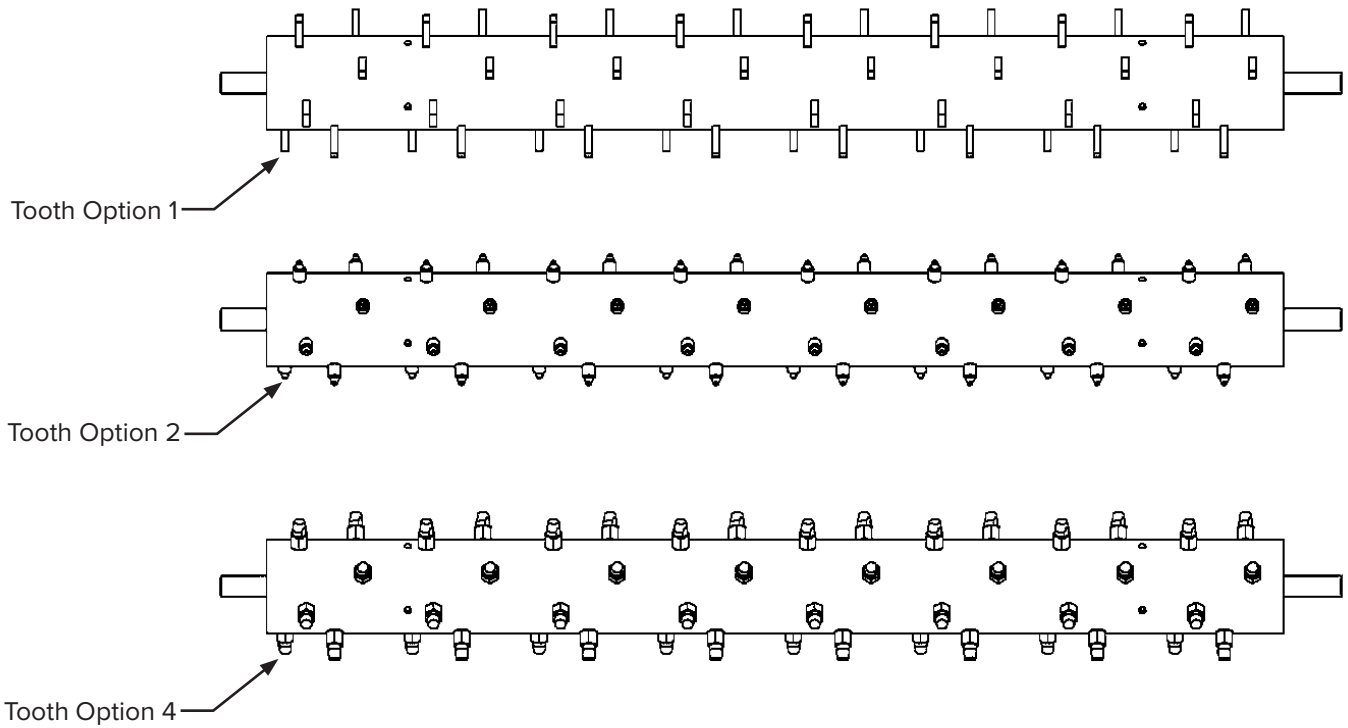

PART NUMBER	TOOTH	QTY 84"	QTY 96"	QTY 120"
232111	Hardened Steel	92	105	132
232112	Carbide			
232117	Hardened Steel Replaceable			
232118	Carbide Replaceable			

ROTOR TOOL OPTION "X"	
1.	Abrasive Resistant Tool
2.	Carbide Tool
3.	Replaceable Tool (Rotor Only)
4.	Replaceable Tool Assembly (with Steel Teeth)

MODEL	PART NUMBER	DESCRIPTION
84"	232321	Abrasive Resistant Tooth Drum
	232322	Carbide Tooth Drum
	232323	Replaceable Tooth Drum (Rotor Only)
	232324	Replaceable Steel Tooth Assembly
96"	232325	Abrasive Resistant Tooth Drum
	232326	Carbide Tooth Drum
	232327	Replaceable Tooth Drum (Rotor Only)
	232328	Replaceable Steel Tooth Assembly
120"	232329	Abrasive Resistant Tooth Drum
	232330	Carbide Tooth Drum
	232331	Replaceable Tooth Drum (Rotor Only)
	232332	Replaceable Steel Tooth Assembly

6. Parts

6.5 3-Point Cat 2 Mount

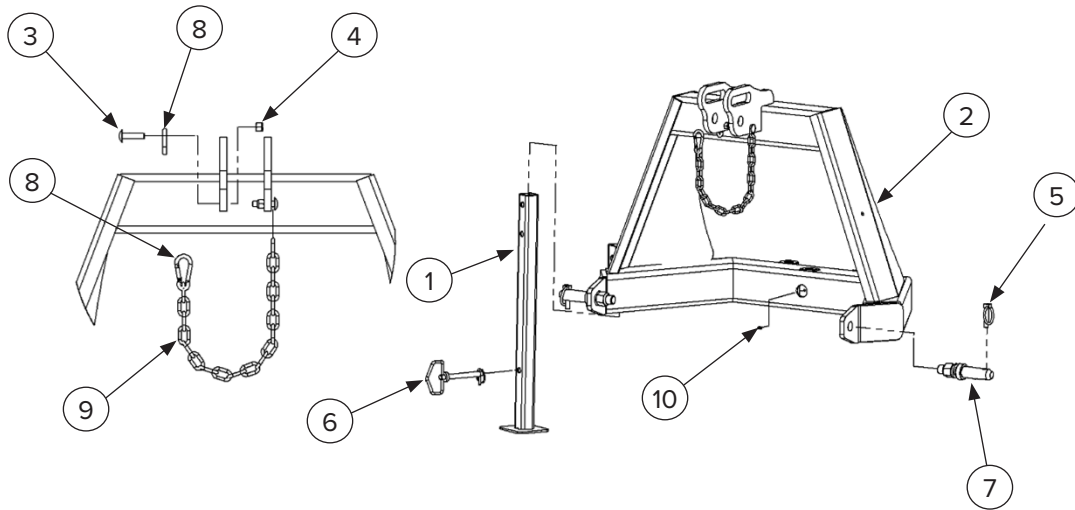

ITEM	PART NUMBER	DESCRIPTION	QTY
1	532028	Stand	1
2	532015	Mount, 3 Point Cat 2	1
3	232304	Bolt, 3/8"-16 X 1-1/2" Carriage	2
4	232279	Nut, 3/8"-16 Nyloc Gr8	2
5	232296	Pin, Linch 7/16" X 1-5/8"	2
6	532016	Pin, 1/2" Drawbar Standard	1
7	532017	Pin, CAT 2 Lift Arm 7/8" X 1-1/8"	2
8	532018	Spring Snap, 1/4" X 2-3/8"	1
9	532019	Chain, 3/16" Grade 30, 20 Links, Plus 1 single link	1
10	232079	Grease Fitting 1/4"-28 Straight	1

6.6 Hydraulic Heavy Skid Steer Mount

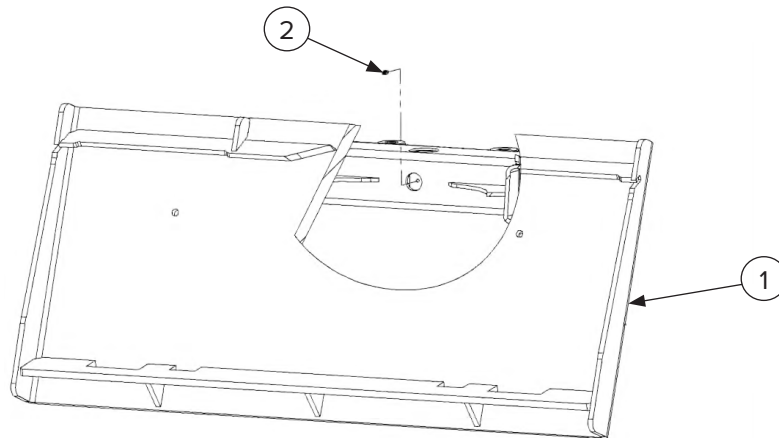

ITEM	PART NUMBER	DESCRIPTION	QTY
1	232333	Mount, Skid Steer Heavy	1
2	232079	Grease Fitting 1/4"-28 Straight	1

6. Parts

6.7 Chain Case PTO

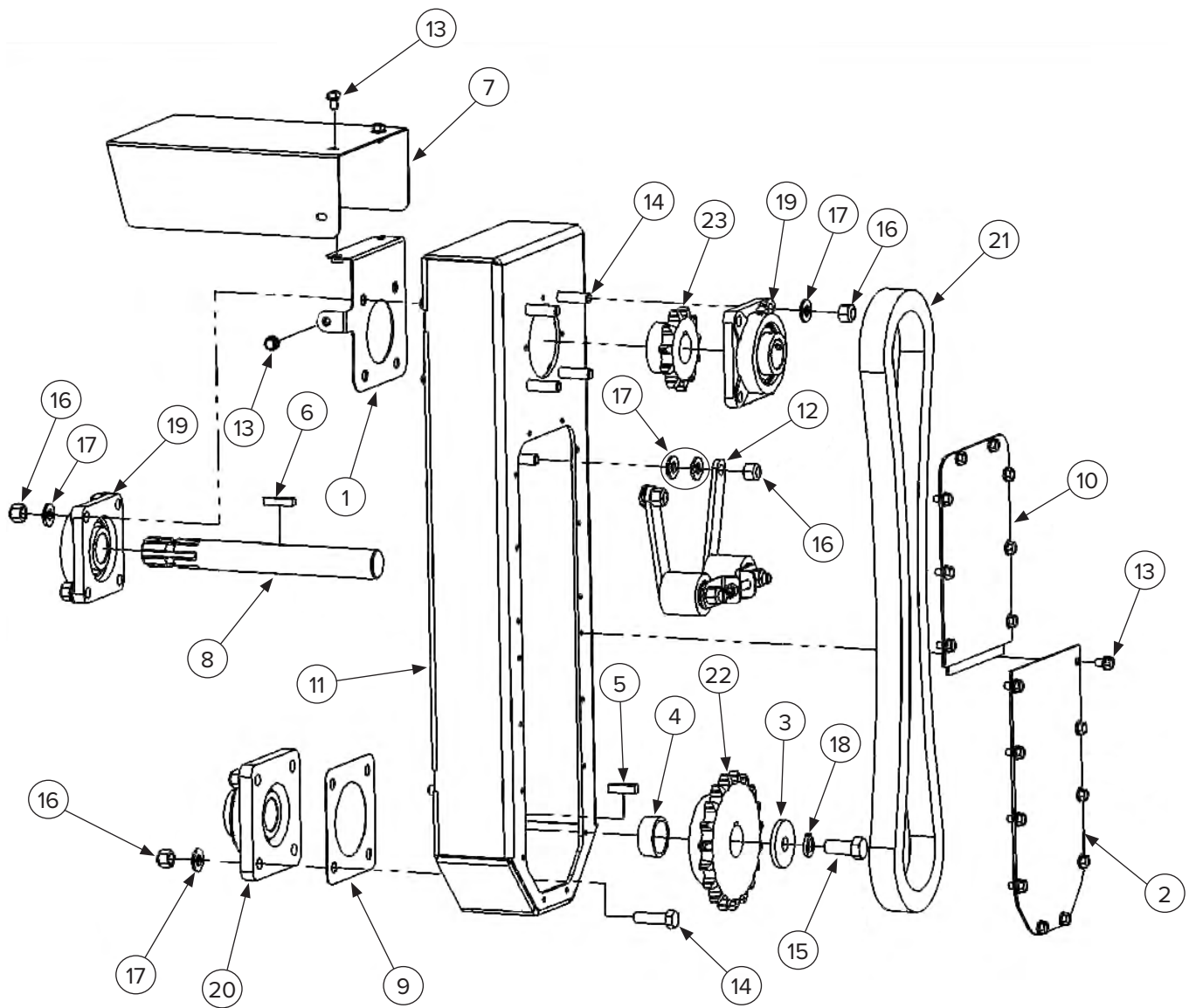

6. Parts

6.7 Chain Case PTO Cont'd

ITEM	PART NUMBER	DESCRIPTION	QTY
1	232334	Bracket, PTO Guard	1
2	232053	Plate, Chain Case Cover	1
3	232249	Washer, 0.25" X 0.656" X 2.25"	1
4	232023	Spacer, 1-1/2" X 0.75"	1
5	232027	Key, 3/8" X 1-3/8"	1
6	232028	Key, 5/16" X 1-1/2"	1
7	232335	Guard, PTO Chain Case	1
8	232336	Shaft, Splined PTO	1
9	232253	Gasket, Bearing UCF 208	1
10	232054	Cover, Upper	1
11	232337	Chain Case, PTO Formed	1
12	232007	Chain Tensioner Assembly	1
13	232222	Bolt, 5/16-18 X 1/2 Anti Vibe	21
14	232264	Bolt, 1/2-13 X 1-3/4" HHCS Gr8	12
15	232266	Bolt, 5/8"-18 X 1-1/2" HHCS Gr8	1
16	232043	Nut, 1/2"-13 Nyloc Gr8	14
17	232234	Washer, 1/2", SAE Gr8	16
18	299845	Washer, 5/8" Split Lock Med	1
19	232043	Bearing, 4 Bolt Flange, UCF207-22	2
20	232050	Bearing, 4 Bolt Flange, UCF208-24	1
21	232013	Chain, No 80 61 Pitch + CL	1
22	232037	Sprocket, 80 P 19 T 1 1/2 Bore	1
23	232036	Sprocket, 80 P 11 T 1-3/8" Bore	1

6. Parts

6.8 Chain Case Hydraulic

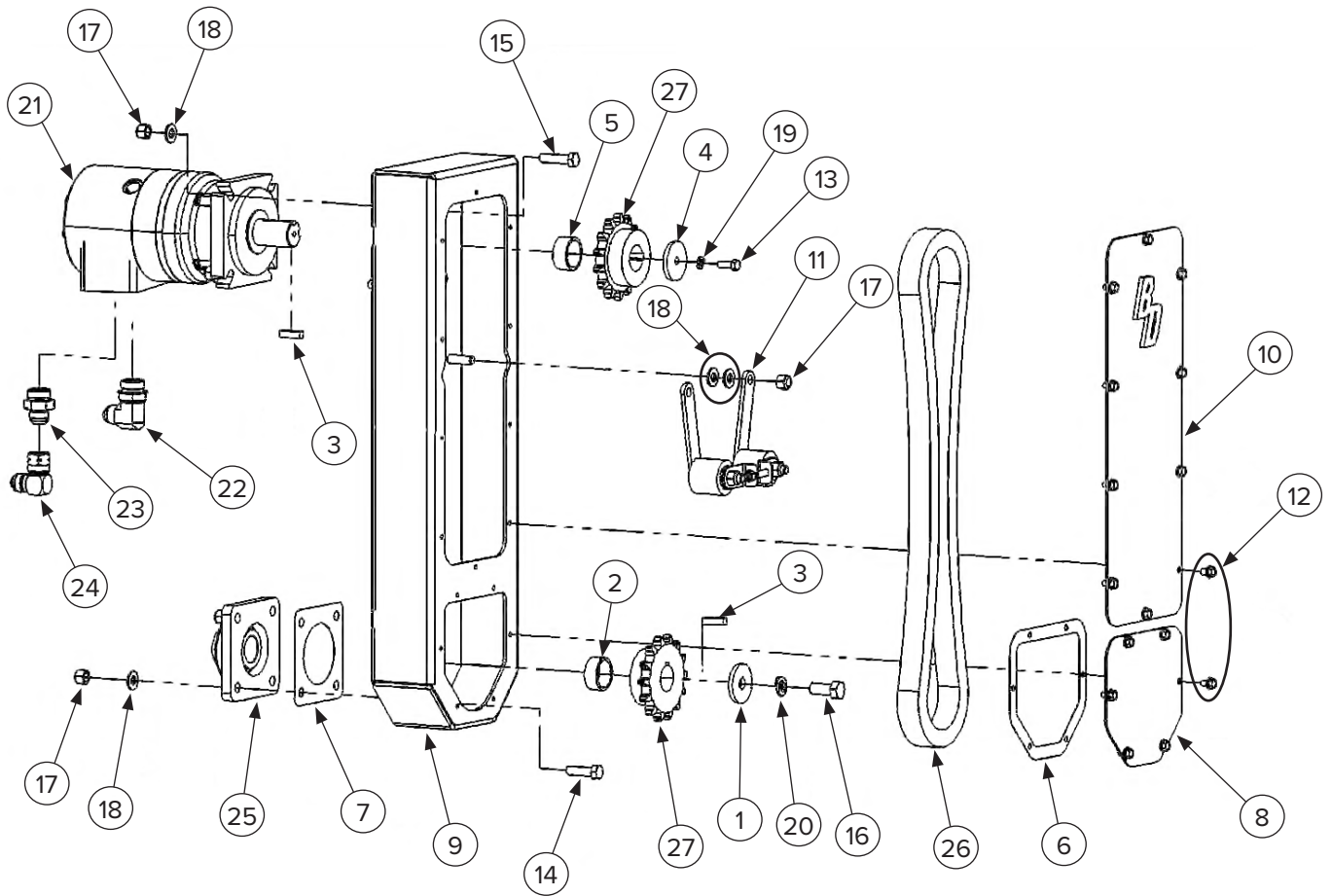

6. Parts

6.8 Chain Case Hydraulic Cont'd

ITEM	PART NUMBER	DESCRIPTION	QTY
1	232249	Washer, 0.25" X 0.656" X 2.25"	1
2	232023	Spacer, 1-1/2" X 0.75	1
3	232027	Key, 3/8" X 1-3/8"	2
4	232250	Washer, 0.25" T X 0.406" ID X 2.25" OD	1
5	232251	Spacer, 1-1/2" X 0.850	1
6	232253	Gasket, Chain Case	1
7	232253	Gasket, Bearing UCF 208	1
8	232254	Cover, Lower Chain Case	1
9	232261	Chain Case	1
10	232262	Cover Chain Case	1
11	232007	Chain Tensioner Assembly	1
12	232222	Bolt, 5/16-18 X 1/2 Anti Vibe	16
13	232263	Bolt, 3/8-16 X 1 HHCS Gr8	1
14	232264	Bolt, 1/2-13 X 1-3/4" HHCS Gr8	4
15	232265	Bolt, 1/2-13 X 2.0" HHCS Gr8	4
16	232266	Bolt, 5/8"-18 X 1-1/2" HHCS Gr8	1
17	232233	Nut, 1/2"-13 Nyloc Gr8	10
18	232234	Washer, 1/2" SAE Gr8	12
19	232267	Washer, 3/8" Split Lock Med	1
20	299845	Washer, 5/8" Split Lock Med	1
21	232339	Hydraulic Motor, 10,000 Series	1
22	232271	Fitting, 12 JICM to 16 ORBM 90 Deg	1
23	232272	Fitting, 12 JICM to 16 ORBM	1
24	232273	Fitting, 12 JICM to 12 JICF 90SW	1
25	232050	Bearing, 4 Bolt Flange, UCF208-24	1
26	232340	Chain, No 80 61 Pitch + CL Heavy	1
27	232025	Sprocket, 80 P14 T 1 1/2 Bore	2

6. Parts

6.9 Chain Tensioner

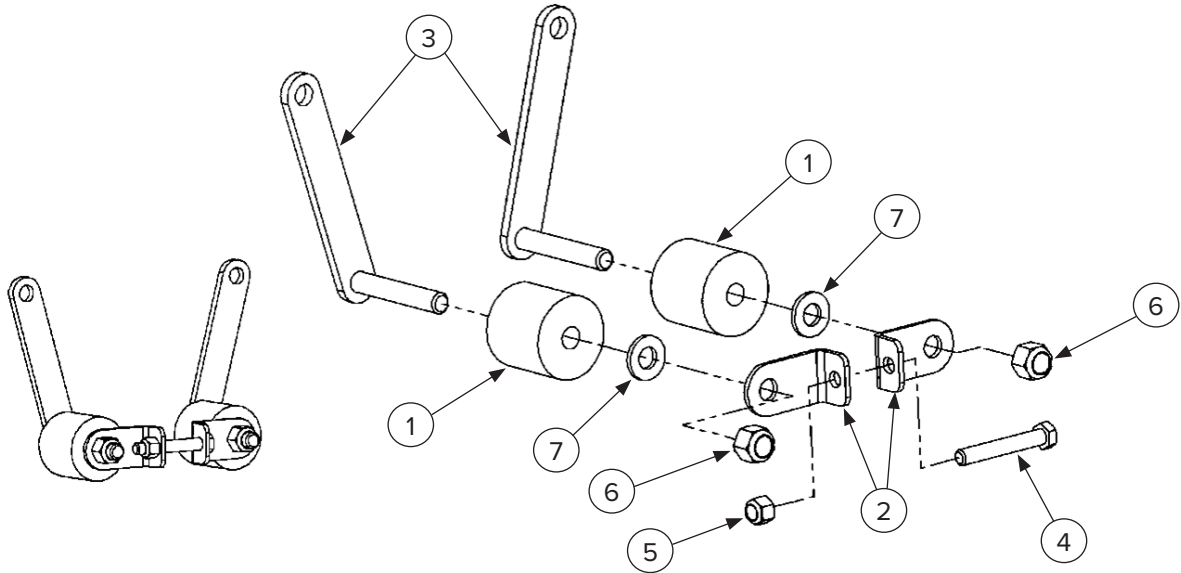

ITEM	PART NUMBER	DESCRIPTION	QTY
1	232275	Roller, Chain Tensioner	2
2	232276	Bracket, Tensioner	2
3	232277	Arm Weldment, Chain Tensioner	2
4	232278	Belt, 3/8" 16 X 2-1/2" Gr8	1
5	232279	Nut, 3/8"-16 Nyloc Gr8	1
6	232233	Nut, 1/2"-13 Nyloc Gr8	2
7	232234	Washer, 1/2", SAE Gr8	2

6.10 Bearing Housing 2 Bolt 232045 (Old Style)

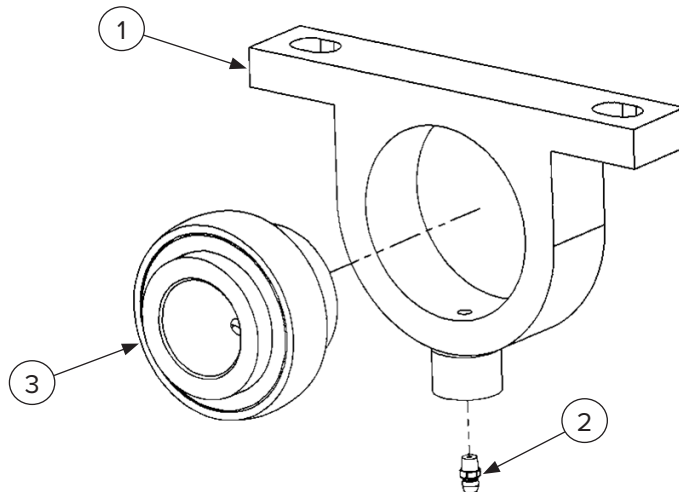

ITEM	PART NUMBER	DESCRIPTION	QTY
1	232046	Bearing Housing, 2 Bolt Steel	1
2	232076	Grease Fitting, 1/4"-28 Straight	1
3	232285	Bearing, 1-1/2" Insert Set Screws	1

6. Parts

6.11 Bearing Housing 2 Bolt 232057 (New Style)

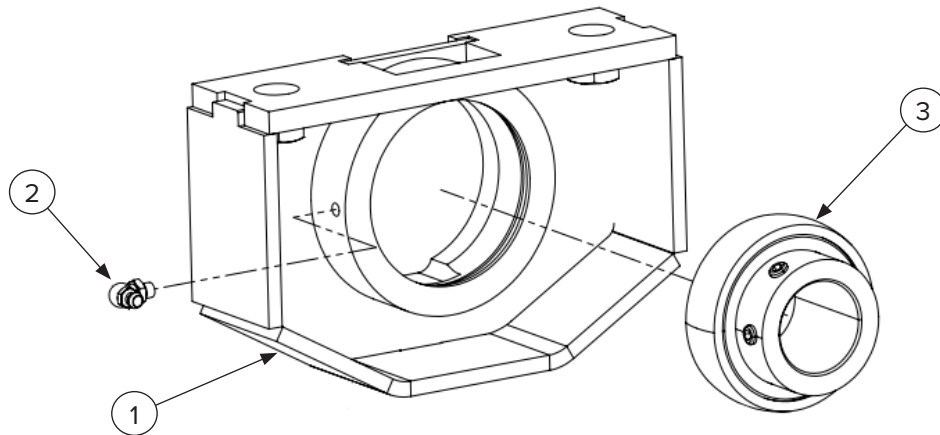

ITEM	PART NUMBER	DESCRIPTION	QTY
1	232058	Bearing Housing	1
2	232284	Grease Fitting, 1/4"-28 90 Degree	1
3	232285	Bearing, 1-1/2" Insert Set Screw	1

6.12 Bearing Housing 4 Bolt 232050

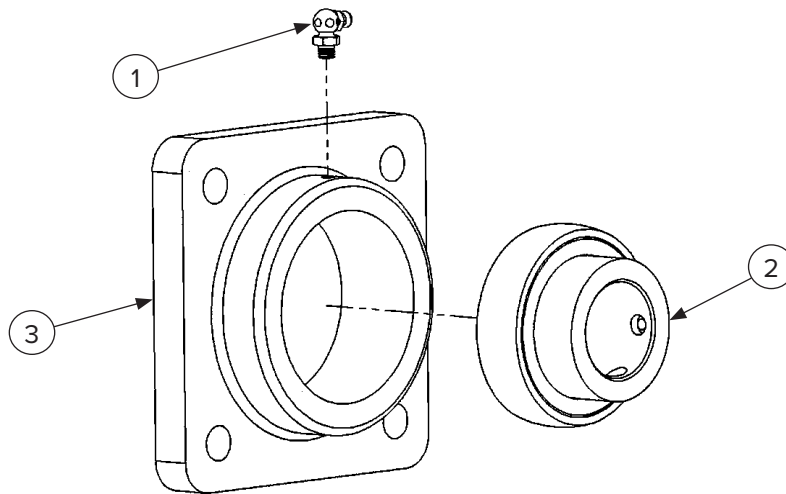

ITEM	PART NUMBER	DESCRIPTION	QTY
1	232284	Grease Fitting, 1/4"-28 90 Deg	1
2	232285	Bearing, 1-1.2" insert set screw	1
3	232051	Bearing Housing, 4 Bolt 208 Steel	1

6. Parts

6.13 Side Shield Options

Side Shield Right Assembly

ITEM	PART NUMBER	DESCRIPTION	QTY
1	232106	Pin, Side Shield	1
2	232105	Side Shield, Right (Direction of Travel)	1

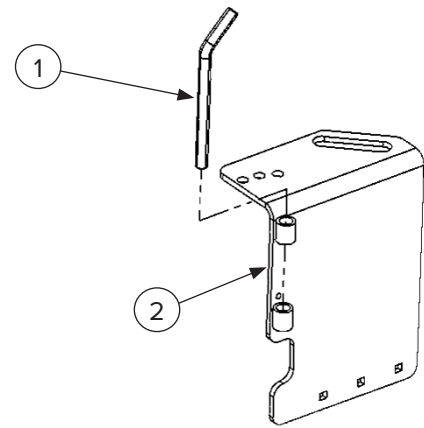

Side Shield Left Assembly

ITEM	PART NUMBER	DESCRIPTION	QTY
1	232106	Pin, Side Shield	1
2	232100	Side Shield, Left (Direction of Travel)	1

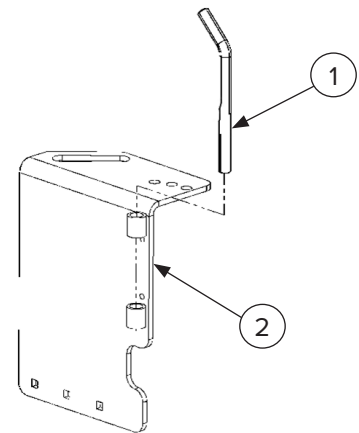

Depth Shoe Assembly

ITEM	PART NUMBER	DESCRIPTION	QTY
1	232344	Depth Shoe	1
2	299336	Bolt, 1/2"-13 X 1-1/2" Carriage Gr8	3
3	232233	Nut, 1/2"-13 Nyloc Gr8	3
4	232234	Washer, 1/2", SAE Gr8	3

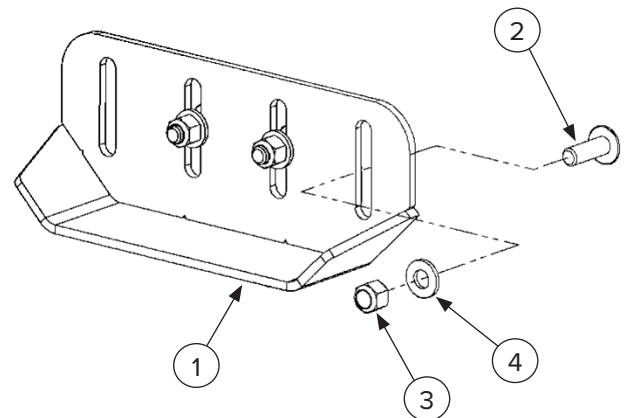

6. Parts

6.14 Gauge Wheel Options

Gauge Wheel Arm Assembly

ITEM	PART NUMBER	DESCRIPTION	QTY
1	232291	Arm, Gauge Wheel Standard	1
2	299443	Bolt, 5/8"-11 X 2-1/2" HHCS Gr8	4
3	232294	Nut, 5/8"-11 Nyloc Gr8	4
4	232093	Washer, 5/8" X 1.312" SAE Gr8	8
5	232079	Grease Fitting, 1/4"-28 Straight	1

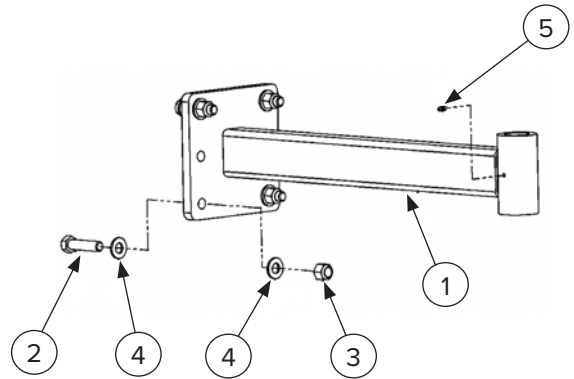

Gauge Wheel, Single with Arm (Standard)

ITEM	PART NUMBER	DESCRIPTION	QTY
1	232290	Spacer, 1-1/2" Gauge Wheel	4
2	232346	Gauge Wheel, Single Caster	1
3	232349	Gauge Wheel Arm Assy	1
4	232296	Pin, Linch 7/16" X 1-5/8"	1

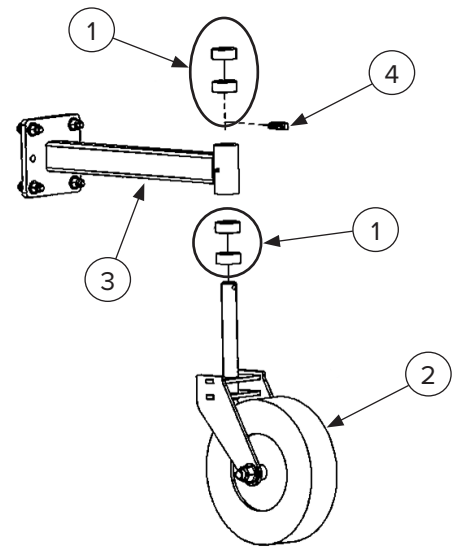

Gauge Wheel, Dual with Arm (Optional)

ITEM	PART NUMBER	DESCRIPTION	QTY
1	232290	Spacer, 1-1/2" Gauge Wheel	4
2	232348	Gauge Wheel, Single Caster	1
3	232349	Gauge Wheel Arm Assy	1
4	232296	Pin, Linch 7/16" X 1-5/8"	1

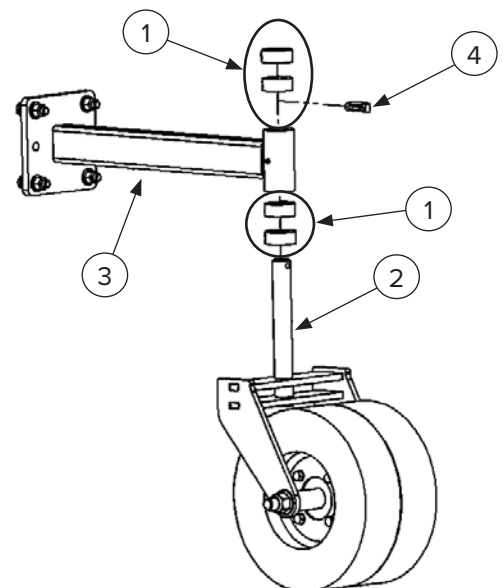

6. Parts

6.15 Material Bar Options

Material Bar Only

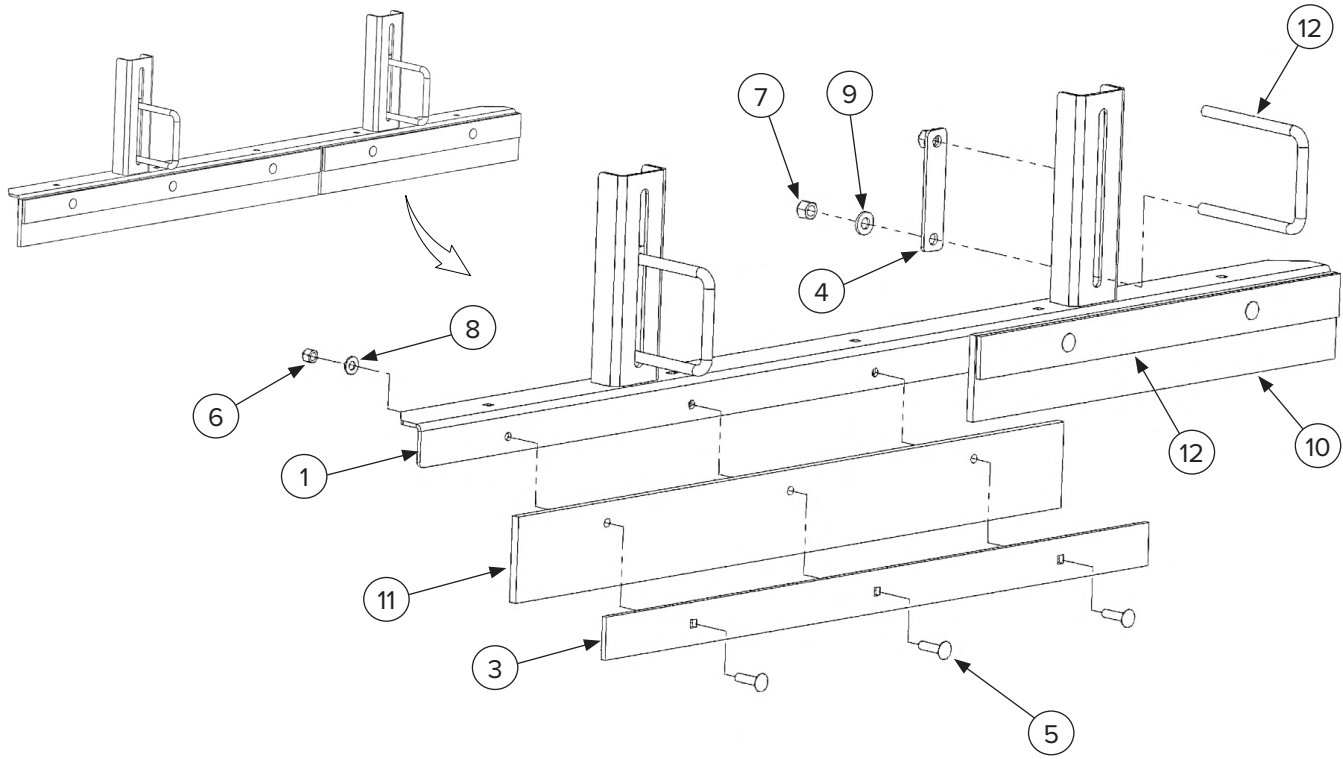

SIZE	PART NUMBER	DESCRIPTION	QTY
84"	232350	Material Bar Assembly	1
96"	232351		1
120"	232352		1

ITEM	PART NUMBER	DESCRIPTION	QTY 7'	QTY 8'	QTY 10'
1	232350	7' Material Bar	1	—	—
	232351	8' Material Bar	—	1	—
	232352	10' Material Bar	—	—	1
2	232297	Bar 24" Clamp	2	1	2
3	232298	Bar 36" Clamp	1	2	2
4	232299	Plate, U-Bolt	2	2	2
5	232304	Bolt, 3/8"-16 X 1-1/2" Carriage	7	8	10
6	232279	Nut 3/8"-18 Nyloc Gr8	7	8	10
7	232233	Nut, 1/2"-13 Nyloc Gr8	4	4	4
8	232314	Washer 3/8" SAE	7	8	10
9	232234	Washer, 1/2" SAE Gr8	4	4	4
10	232306	Flap 2 Ply 24" Rubber	2	1	1
11	232307	Flap 2 Ply 36" Rubber	1	2	2
12	232130	U-Bolt, 1/2"	2	2	2

6. Parts

6.15 Material Bar Options Cont'd

Material Bar and Shield

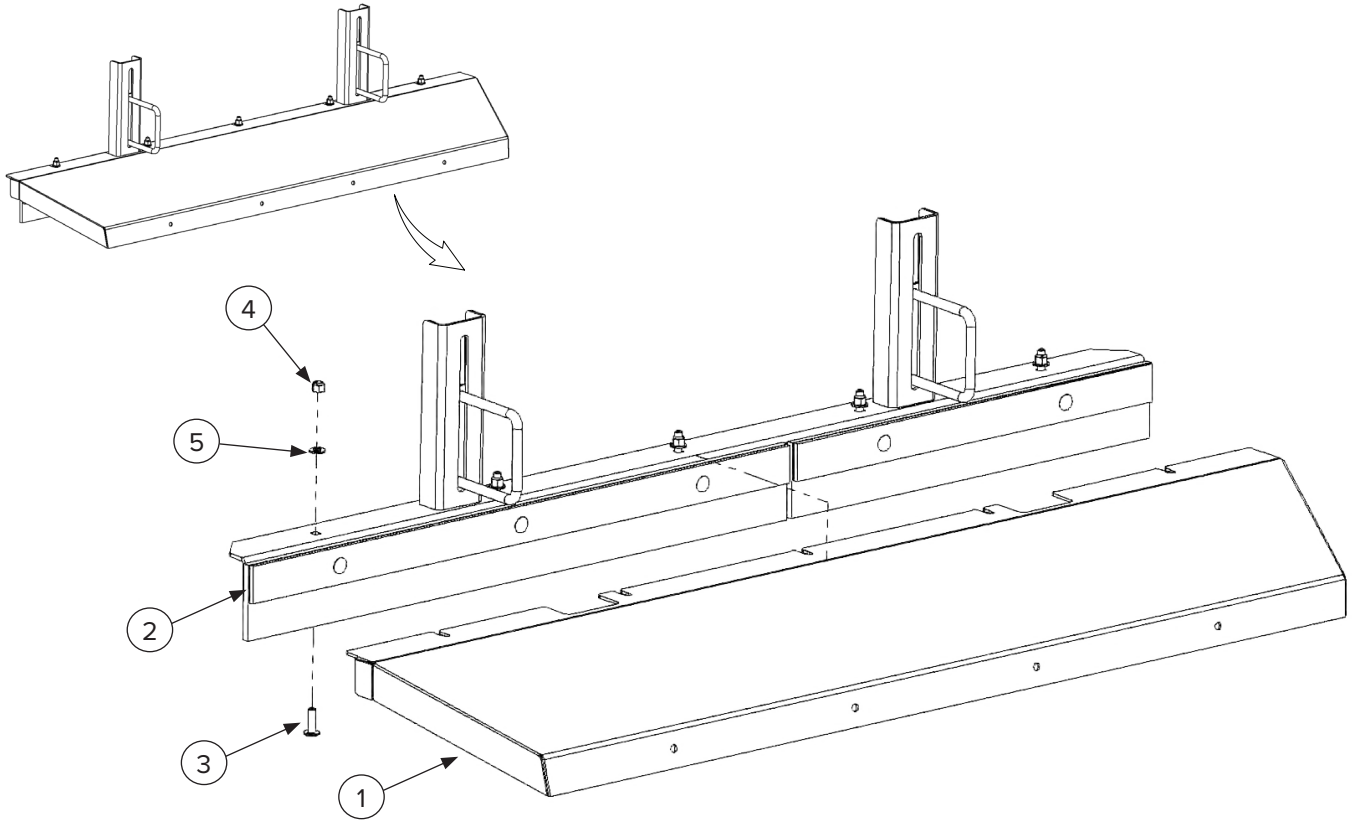

SIZE	PART NUMBER	DESCRIPTION	QTY
84"	232365	Material Bar Assembly with Shield	1
96"	232366		1
120"	232367		1

ITEM	PART NUMBER	DESCRIPTION	QTY 7'	QTY 8'	QTY 10'
1	232311	Shield 7' Rotor	1	—	—
	232312	Shield 8' Rotor	—	1	—
	232368	Shield 10' Rotor	—	—	1
2	232350	7' Material Flat Bar	1	—	—
	232351	8' Material Flat Bar	—	1	—
	232352	10' Material Flat Bar	—	—	1
3	232313	Bolt, 3/8"-16 X 1-1/4" Carriage	7	9	10
4	232279	Nut 3/8" - 16 Nyloc Gr8	7	9	10
5	232314	Washer 3/8" SAE	7	9	10

6. Parts

6.15 Material Bar Options Cont'd

Material Bar with Shield and Skirt

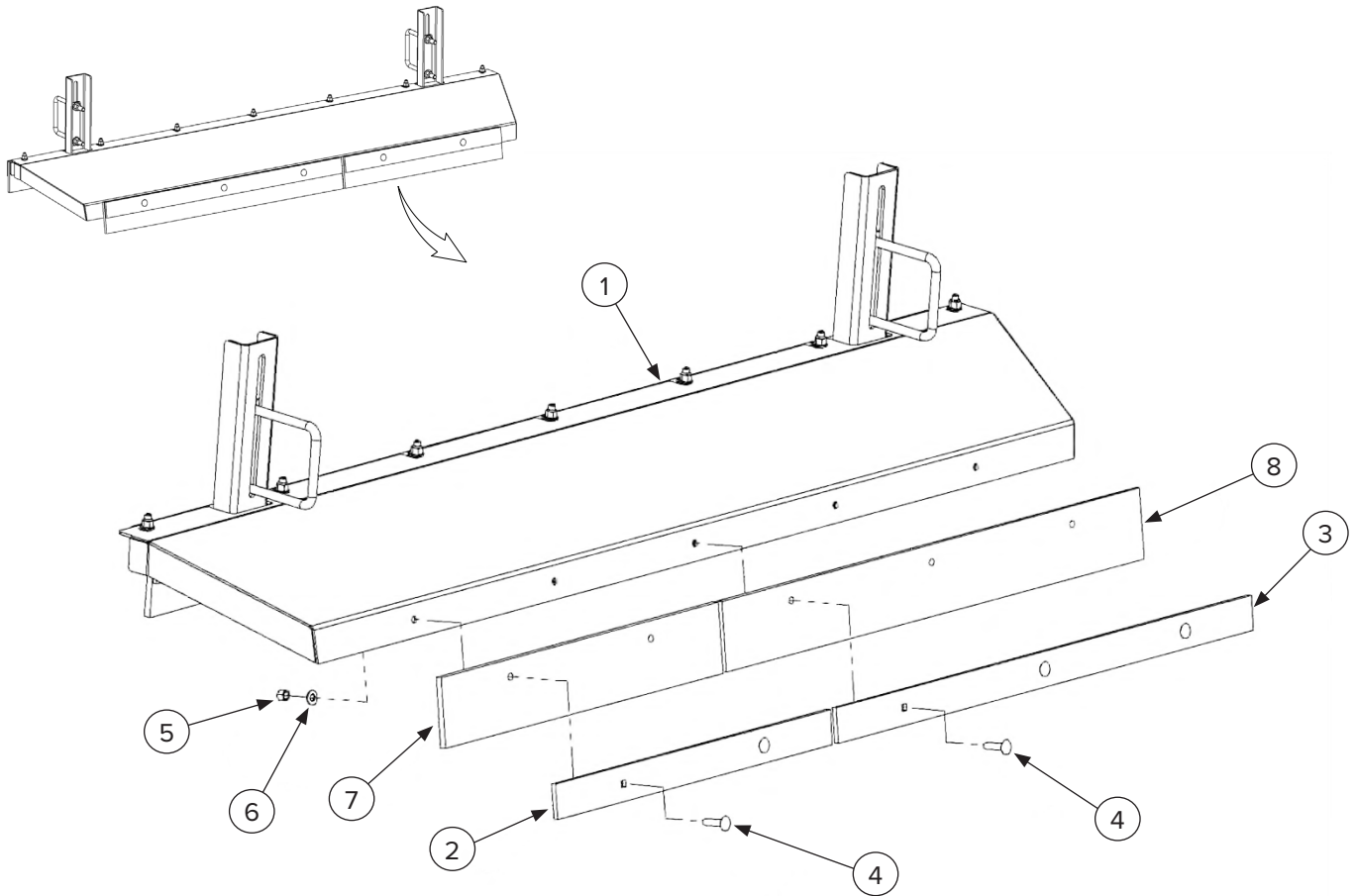

SIZE	PART NUMBER	DESCRIPTION	QTY
84"	232369	Material Bar Assembly with Shield with Skirt Assembly	1
96"	232370		1
120"	232371		1
84"	232365	Material Bar Assembly with Shield	1
96"	232366		1
120"	232367		1

ITEM	PART NUMBER	DESCRIPTION	QTY 7'	QTY 8'	QTY 10'
2	232297	Bar 24" Clamp	—	2	1
3	232298	Bar 36" Clamp	2	1	2
4	232304	Bolt, 3/8"-16 X 1-1/2" Carriage	6	7	8
5	232279	Nut, 3/8"-16 Nyloc Gr8	6	7	8
6	232314	Washer, 3/8" SAE Gr8	6	7	8
7	232306	Flap 2 Ply 24" Rubber	—	2	1
8	232307	Flap 2 Ply 36" Rubber	2	1	1

7. Specifications

7.1 Attachment Specifications

DESCRIPTION	84"	96"	120"
Overall Width	94"	106"	130"
Overall Height	35"		
Working Width	84"	96"	120"
Weight	1420 lbs	1530 lbs	1640 lbs
Angled Working Width (10°)	81"	93"	117"
Angled Working Width (20°)	78"	90"	114"
Drive	Hydraulic		
Chain	80 Heavy		
Mount	Skid Steer		
Rotor	8" Diameter		
Material Bar	Adjustable		
Side Shields	Standard		
Hydraulic Angle	Optional		
Max Flow	30 – 40 GPM		
Max Pressure	4000 PSI		

7. Specifications

7.2 Torque Specifications

Standard Hardware and Lock Nuts

BOLT TYPE	SAE GRADE 5		SAE GRADE 8		LOCK NUTS			
	Nominal Size	Plated or Unplated Silver	Plated W/ ZnCr Gold	Plated or Unplated Silver	Plated W/ ZnCr Gold	Plated or Unplated Silver	Plated W/ ZnCr Gold	W/ Grade 5 Bolt
1/4	55 in / lb (6.2 N•m)	72 in / lb (8.1 N•m)	86 in / lb (9.7 N•m)	112 in / lb (12.6 N•m)	121 in / lb (13.6 N•m)	157 in / lb (17.7 N•m)	61 in / lb (6.9 N•m)	86 in / lb (9.8 N•m)
5/16	115 in / lb (13 N•m)	149 in / lb (17 N•m)	178 in / lb (20 N•m)	229 in / lb (26 N•m)	250 in / lb (28 N•m)	325 in / lb (37 N•m)	125 in / lb (14 N•m)	176 in / lb (20 N•m)
3/8	17 ft / lb (23 N•m)	22 ft / lb (30 N•m)	26 ft / lb (35 N•m)	34 ft / lb (46 N•m)	37 ft / lb (50 N•m)	48 ft / lb (65 N•m)	19 ft / lb (26 N•m)	26 ft / lb (35 N•m)
7/16	27 ft / lb (37 N•m)	35 ft / lb (47 N•m)	42 ft / lb (57 N•m)	54 ft / lb (73 N•m)	59 ft / lb (80 N•m)	77 ft / lb (104 N•m)	30 ft / lb (41 N•m)	42 ft / lb (57 N•m)
1/2	42 ft / lb (57 N•m)	54 ft / lb (73 N•m)	64 ft / lb (87 N•m)	83 ft / lb (113 N•m)	91 ft / lb (123 N•m)	117 ft / lb (159 N•m)	45 ft / lb (61 N•m)	64 ft / lb (88 N•m)
9/16	60 ft / lb (81 N•m)	77 ft / lb (104 N•m)	92 ft / lb (125 N•m)	120 ft / lb (163 N•m)	130 ft / lb (176 N•m)	169 ft / lb (229 N•m)	65 ft / lb (88 N•m)	92 ft / lb (125 N•m)
5/8	83 ft / lb (112 N•m)	107 ft / lb (145 N•m)	128 ft / lb (174 N•m)	165 ft / lb (224 N•m)	180 ft / lb (244 N•m)	233 ft / lb (316 N•m)	90 ft / lb (122 N•m)	127 ft / lb (172 N•m)
3/4	146 ft / lb (198 N•m)	189 ft / lb (256 N•m)	226 ft / lb (306 N•m)	293 ft / lb (397 N•m)	319 ft / lb (432 N•m)	413 ft / lb (560 N•m)	160 ft / lb (217 N•m)	226 ft / lb (306 N•m)
7/8	142 ft / lb (193 N•m)	183 ft / lb (248 N•m)	365 ft / lb (495 N•m)	473 ft / lb (641 N•m)	515 ft / lb (698 N•m)	667 ft / lb (904 N•m)	258 ft / lb (350 N•m)	364 ft / lb (494 N•m)
1	213 ft / lb (289 N•m)	275 ft / lb (373 N•m)	547 ft / lb (742 N•m)	708 ft / lb (960 N•m)	773 ft / lb (1048 N•m)	1000 ft / lb (1356 N•m)	386 ft / lb (523 N•m)	545 ft / lb (739 N•m)



Warranty

MANUFACTURER'S LIMITED WARRANTY

BLUE DIAMOND® ATTACHMENTS, a manufacturer of quality attachments, warrants new BLUE DIAMOND® ATTACHMENTS products and/or attachments at the time of delivery to the original purchaser, to be free from defects in material and workmanship when properly set up and operated in accordance with the recommendations set forth by BLUE DIAMOND® ATTACHMENTS, LLC.

BLUE DIAMOND® ATTACHMENTS liability for any defect with respect to accepted goods shall be limited to repairing the goods at a BLUE DIAMOND® ATTACHMENTS designated location or at an authorized dealer location, or replacing them, as BLUE DIAMOND® ATTACHMENTS shall elect. The above shall be in accordance with BLUE DIAMOND® ATTACHMENTS warranty adjustment policies. BLUE DIAMOND® ATTACHMENTS obligation shall terminate twelve (12) months for the Severe Duty Series 3 Power Rake after the delivery of the goods to original purchaser.

This warranty shall not apply to any machine or attachment which shall have been repaired or altered outside the BLUE DIAMOND® ATTACHMENTS factory or authorized BLUE DIAMOND® ATTACHMENTS dealership or in any way so as in BLUE DIAMOND® ATTACHMENTS judgment, to affect its stability or reliability, nor which has been subject to misuse, negligence or accident beyond the company recommended machine rated capacity.

WARRANTY CLAIM

To submit a warranty claim, a claim must be filed with BLUE DIAMOND® ATTACHMENTS before work is performed. The BLUE DIAMOND® PRODUCT SUPPORT TEAM will advise repairs and applicable parts exchanges. Tampering with the failed part may void the warranty. This warranty does not include freight or delivery charges incurred when returning machinery for servicing. Dealer mileage, service calls, and pickup/delivery charges are the customers' responsibility.

EXCLUSIONS OF WARRANTY

Except as otherwise expressly stated herein, BLUE DIAMOND® ATTACHMENTS makes no representation or warranty of any kind, expressed or implied, AND MAKES NO WARRANTY OF MERCHANTABILITY IN RESPECT TO ITS MACHINERY AND/OR ATTACHMENTS ARE FIT FOR ANY PARTICULAR PURPOSE. BLUE DIAMOND® ATTACHMENTS shall not be liable for incidental or consequential damages for any breach or warranty, including but not limited to inconvenience, rental of replacement equipment, loss of profits or other commercial loss. Upon purchase, the buyer assumes all liability for all personal injury and property resulting from the handling, possession, or use of the goods by the buyer.

No agent, employee, or representative of BLUE DIAMOND® ATTACHMENTS has any authority to bind BLUE DIAMOND® ATTACHMENTS to any affirmation, representation, or warranty concerning its machinery and/or attachments except as specifically set forth herein.

This warranty policy supersedes any previous documents.

NOTE: Blue Diamond® Attachments is a trademark of BLUE DIAMOND® ATTACHMENTS



QUALITY | DEPENDABILITY | INTEGRITY

Blue Diamond® Attachments
4512 Anderson Road, Knoxville, TN 37918
888-376-7027