



Blue Diamond® Attachments Extreme Duty Series 2 Augers Owner's Manual



CRITICAL DO NOT CONNECT OR OPERATE YOUR DRIVE UNIT WITHOUT FIRST HAVING READ AND UNDERSTOOD THIS STATEMENT

Your Blue Diamond Extreme Duty Series 2 Auger is a high performance attachment that is designed for Drilling, Screw Anchoring (Pier) installation, Core Barreling and other extreme applications where it is seeing high levels of torque. To avoid premature wear and failure, and to fulfill your terms of warranty please read this statement.

All **Blue Diamond® Extreme Duty Series 2 Augers** must have a first oil change within the **first 30hrs (extreme use) or 50hrs (Moderate use) or 3mths** (which ever comes first) of use to ensure the bed in of the drive unit. For more detailed information please read pages 43 - 46

If the first oil change is not performed within this period excessive wear within the gearbox will occur that will cause premature failure. All Warranty will be void.

Oil must then be changed thereafter every 300/500hrs and a full service every 12mths must be performed by an authorized service agent to ensure Warranty requirements are met.

In the event of a failure under the warranty period:

Contact Blue Diamond immediately, **DO-NOT DISASSEMBLE YOUR DRIVE** without first obtaining written permission and instructions from Blue Diamond .

Proof of service must be provided in hard copy form of both operational and service history (including serial number of gearbox and hydraulic motor) records. Service must be performed by an **authorized Blue Diamond® service agent.**

2 TABLE OF CONTENTS

CONTENTS		PAGE
1	CRITICAL INFORMATION - SERVICE INTERVALS	3
2	TABLE OF CONTENTS	4
3	TO THE PURCHASER - ABOUT THIS MANUAL	5
4	SERVICE & PREPARATION FOR USE	6
5	SAFETY PRECAUTIONS - GENERAL INFORMATION	8
6	SAFETY - WORKING WITH THE ATTACHMENT	14
6	SAFETY - DECAL LOCATION	16
7	BEFORE USE	17
7	TECHNICAL SPECIFICATIONS	38
8	COMMISSIONING PROCEDURE	20
9	OPERATING INSTRUCTIONS	24
10	2 SPEED INSTALLATION INSTRUCTIONS	31
11	2 SPEED OPERATING INSTRUCTIONS	41
12	MAINTENANCE	43
13	AUGERS BITS, WEARPARTS & SPARE PARTS	48
14	TROUBLE SHOOTING	50
15	CONTACT INFORMATION	52
16	WARRANTY	53

THANK YOU

Congratulations on the purchase of your new High Performance Blue Diamond Extreme Duty Series 2 Auger. This product was carefully designed and manufactured to give you years of dependable service. It is mandatory that oil changes are performed at the specified interval to keep it in top working condition (maintenance chapter 12).

The complete manual must be read and understood before connecting and operating. Be sure to observe all safety precautions and maintenance procedures as described in this manual.

Optional Extras are available for special applications or extreme conditions: these are noted throughout the manual. Contact your Blue Diamond dealer for any further information pertaining to this product or for further information on other products available in the Blue Diamond range.

ABOUT THIS MANUAL

This manual has been designed to help you do a better, safer job. **Read this manual carefully and become familiar with its contents before connecting and operating.**

Remember never let anyone operate this unit without reading the Safety Precautions and Operating Instructions sections of this manual. Unless noted otherwise, right and left sides are determined from the position of the machine operator when facing forward.



SAFETY ALERT SYMBOL

This is the Safety Alert Symbol used by this industry. This symbol is used to warn of possible injury. Be sure to read all warnings carefully. They are included for your safety and for the safety of others working with you.

Model	<input type="text"/>
Serial No.	<input type="text"/>
Flow (max)	<input type="text"/>
Pressure (max)	<input type="text"/>
Power (max)	<input type="text"/>
Approx. Oil Capacity	<input type="text"/>
<input type="text"/>	<input type="text"/>
	Weight
	<input type="text"/>

DE-00????

4 SERVICE & PREPARATION FOR USE

Your Blue Diamond Extreme Duty Series 2 Auger is a user non serviceable part. Unauthorized disassembly will void warranty. All service and warranty must be performed by an authorized Blue Diamond dealer. Contact your local Blue Diamond dealer for details.

To facilitate warranty or service, record the model and serial number of your unit in the space provided on this page. This information may be obtained from the identification plate located on the product.

MODEL _____

SERIAL NUMBER _____

DATE PURCHASED _____

The parts department needs this information to ensure accurate parts can be sent to the authorised service agent.

MODELS COVERED IN THIS MANUAL

DRILLING DRIVES	ANCHOR DRIVES	2-SPEED DRIVES
EX1, EX2, EX3, EX4, EX4HF, EX5HF, EX6HF, EX7HF, EX9HF, EX12HF, EX13HF, EX16HF, EX20HF, EX25HF, EX30HF, EX7LP, EX9LP, EX12LP, EX13LP, EX16LP, EX20LP, EX25LP	AEX5HF, AEX6HF, AEX7HF, AEX7LP, AEX9HF, AEX9LP, AEX 12HF, AEX12LP, AEX13HF, AEX13LP, AEX16HF, AEX16LP, AEX20HF, AEX20LP, AEX25HF, AEX25LP, AEX30HF	2EX5HF, 2EX6HF, 2EX7HF, 2EX9HF, 2EX12HF, 2EX13HF, 2EX16HF, 2EX20HF, 2EX25HF, 2EX30HF, 2EX7LP, 2EX9LP, 2EX12LP, 2EX13LP, 2EX16LP, 2EX20LP, 2EX30LP, 2AEX5HF, 2AEX6HF, 2AEX7HF, 2AEX9HF, 2AEX12HF, 2AEX13HF, 2AEX16HF, 2AEX20HF, 2AEX25HF, 2AEX30HF, 2AEX7LP, 2AEX13LP, 2AEX9LP, 2AEX12LP, 2AEX16LP, 2AEX20LP, 2AEX25LP

4 SERVICE & PREPARATION FOR USE

To avoid any inconvenience before operation, please check that you have received the following items which you have ordered. Items may differ depending on type of machine the drive units are to be fitted to.

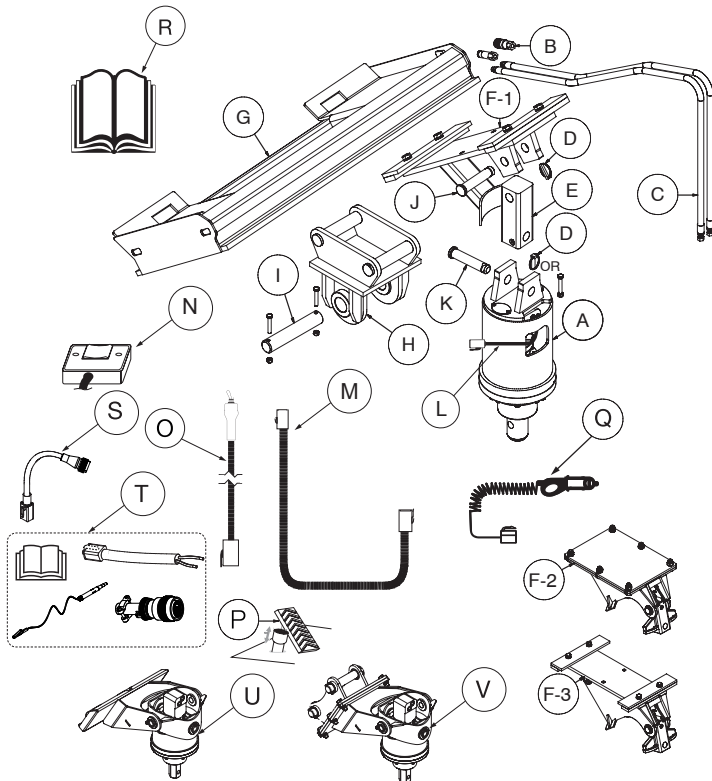

REF	DESCRIPTION	QTY	SINGLE SPEED	2-SPD 12V/24V
A	STD DRIVE UNIT - OR - SCS DRIVE UNIT	1	•	•
B	QUICK RELEASE COUPLERS	set	•	•
C	HYDRAULIC HOSE KIT	set	•	•
D	LYNCH PIN (CLIP) OR BOLT	1	•	•
E	LINKAGE SUIT STD DRIVE UNIT	1	•	•
K	STD DRIVE UNIT TO LINKAGE PIN	1	•	•
L	BDA MOTOR CONTROL HARNESS	1	N/A	•
M	EXTENSION HARNESS 3M/6M/12M/15M	1	N/A	OPTIONAL
N	2-SPEED CONTROLLER	1	N/A	OPTIONAL
O	REMOTE TOGGLE SWITCH	1	N/A	OPTIONAL
P	REMOTE FLOOR MOUNTED SWITCH	1	N/A	OPTIONAL
Q	12V/24V POWER LEAD	1	N/A	OPTIONAL
R	OPERATORS MANUAL	1	•	•
REF	FOR SKID STEER LOADERS	QTY	SINGLE SPEED	2-SPD 12V/24V
G	SLIDE FRAME	1	•	•
J	CRADLE TO LINKAGE PIN	1	•	•
F1	STD SLIDE CRADLE	1	•	•
F3	SCS CRADLE (IF APPLICABLE)	1	•	•
S	ADAPTOR HARNESS CAT/ASV/TEREX	1	N/A	OPTIONAL
T	ADAPTOR HARNESS KIT (14-PIN)	1	N/A	OPTIONAL
REF	FOR EXCAVATORS	QTY	SINGLE SPEED	2-SPD 12V/24V
H	STD EXCAVATOR HITCH	1	•	•
I	LINKAGE PIN	1	•	•
F2	SCS CRADLE (IF APPLICABLE)	1	•	•
REF	FOR MINI MACHINES	QTY	SINGLE SPEED	2-SPD 12V/24V
U	DRIVE TO SUIT MINI LOADER	1	•	N/A
V	DRIVE TO SUIT MINI EXCAVATOR	1	•	N/A

*NOTE • DENOTES SUPPLIED

All other machines - Custom made frame to suit.

TAKE NOTE! THIS SAFETY ALERT SYMBOL FOUND THROUGHOUT THIS MANUAL IS USED TO CALL YOUR ATTENTION TO INSTRUCTIONS INVOLVING YOUR PERSONAL SAFETY OR OTHERS. FAILURE TO FOLLOW THESE INSTRUCTIONS CAN RESULT IN INJURY OR DEATH.

THIS SYMBOL MEANS:



**ATTENTION!
BECOME ALERT!
YOUR SAFETY IS INVOLVED!**

SIGNAL WORDS: Note the use of signal words DANGER, WARNING, and CAUTION with the safety messages. The appropriate signal word for each has been selected using the following guidelines:

DANGER: Indicates an imminently hazardous situation, which if not avoided, will result in death or serious injury. This signal word is to be limited to the most extreme situations, typically for machine components which, for functional purposes, cannot be guarded.

WARNING: Indicates a potentially hazardous situation, which if not avoided, could result in death or serious injury, and includes hazards that are posed when guards are removed. It may also be used to alert against unsafe practices and indicate potential failure or damage to equipment.

CAUTION: Indicates a potentially hazardous situation, which if not avoided, may result in minor or moderate injury. It may also be used to alert against unsafe practices.

This section is composed of various warnings and safety tips. **Read and learn all the information in this section before you attempt to use your attachment.** Also read your machine's owner's manual before using your equipment. This knowledge will help you operate your unit safely. **Do not take this information lightly, it is presented for your benefit and for the benefit of others working around you.**

The Safety Alert Symbol **A** will be used throughout this manual. It will appear with the word **DANGER, WARNING, or CAUTION**, and a safety message pertaining to the specific topic being covered. Take the time to read these messages as you come across them.

5 SAFETY PRECAUTIONS –GENERAL INFORMATION

WARNING



KNOW WHERE UTILITIES ARE

Observe overhead electrical and other utility lines. Be sure equipment will clear them. When digging, call or your local UTILITIES location service provider for location of buried utility lines, gas, water, and sewer, as well as any other hazard you may encounter.

WARNING



EXPOSURE TO RESPIRABLE CRYSTALLINE SILICA DUST ALONG WITH OTHER HAZARDOUS DUSTS MAY CAUSE SERIOUS OR FATAL RESPIRATORY DISEASE.

It is recommended to use dust suppression, dust collection and if necessary personal protective equipment during the operation of any attachment that may cause high levels of dust.

WARNING



REMOVE PAINT BEFORE WELDING OR HEATING

Hazardous fumes/dust can be generated when paint is heated by welding, soldering or using a torch. Do all work outside or in a well ventilated area and dispose of paint and solvent properly. Remove paint before welding or heating. When sanding or grinding paint, avoid breathing the dust. Wear an approved respirator. If you use solvent or paint stripper, remove stripper with soap and water before welding. Remove solvent or paint stripper containers and other flammable material from area. Allow fumes to disperse at least 15 minutes before welding or heating.

WARNING



END OF LIFE DISPOSAL

At the completion of the useful life of the unit, drain all fluids and dismantle by separating the different materials (rubber, steel, plastic, etc.). Follow all federal, state and local regulations for recycling and disposal of the fluid and components.

5 SAFETY PRECAUTIONS - GENERAL INFORMATION

WARNING OPERATING THE PLANETARY DRIVE

A

An operator must not use drugs or alcohol, which can change his or her alertness or coordination. An operator taking prescription or over the counter drugs should seek medical advice on whether or not he or she can safely operate equipment.

All bystanders should be kept a minimum of 2 feet away from the working area of the drive.

Do not allow site workers to climb or ride on a drill mast, planetary drive, auger bits or auger e tension at any time, including while stationary, in operation or being moved or rotated.

Operate only from the operator s station.

Avoid steep hillside operation which could cause the machine to overturn. Consult your machines operator s and safety manuals for ma imum incline allowable.

WARNING

A

Reduce speed when driving over rough terrain, on a slope, or turning, to avoid overturning the vehicle.

- Travel only with the planetary drive in a safe transport position to prevent uncontrolled movement. Drive slowly over rough ground and on slopes.

Tether any auger, anchor or extensions connected to the drive with a chain if necessary, to prevent uncontrolled swinging of the attachments when moving from position to position.

Do not drive close to ditches, excavations, etc., cave in could result.

Before e iting the machine, lower the attachment to the ground, apply the parking brakes, turn off the prime mover s engine, and remove the key.

Flow and pressure gauges, fittings, and hoses must have a continuous operating pressure rating of at least 25% higher than highest pressures of the system.

Do not smoke when refueling the prime mover. Allow room in the fuel tank for expansion. Wipe up any spilled fuel. Secure cap tightly when done.

WARNING

A

Remove the auger drive from the prime mover before transporting to and from the job site.

Planetary Drives shall be used only for their designed intent and shall not be loaded beyond their rated capacity. Over loading or e ceeding the manufacturers specifications will void all warranty.

WARNING OPERATING THE PLANETARY DRIVE CONT...

A

Drill stem rotation must be stopped before adding or removing sections, or making adjustments to the drill stem or sampling equipment.

Augers shall be cleaned only when the rotating mechanism is in neutral and the auger stopped. Long handled shovels shall be used to move cuttings from the auger. Materials heavier than 22lbs must be moved mechanically or by using at least two people.

Drilling operations must be stopped in the event of local thunderstorm, or lightning activity. During operation, weather conditions shall be monitored: operations shall cease during electrical storms or when electrical storms are imminent.

Open bore holes must be capped and flagged.

WARNING STORAGE OF THE PLANETARY DRIVE

A

- Seal hydraulic quick couplers from contaminants and secure all hydraulic hoses off the ground to help prevent damage.
- Clean the unit thoroughly, removing all mud, dirt, and grease.
- Inspect for visible signs of wear, breakage, or damage. Order any parts required and make the necessary repairs to avoid delays upon removal from storage.
- Check that drive unit motor and hoses are full of clean oil and planetary is full.
- Coat liberally with grease the output shaft and collar, extension shaft and collar, and all connecting pins to prevent rust and reduce wear.
- Tighten loose nuts, capscrews and hydraulic connections.
- Replace decals that are damaged or in unreadable condition.
- Store unit in a dry and protected place. Leaving the unit outside will materially shorten its life.

5 SAFETY PRECAUTIONS - GENERAL INFORMATION

WARNING GROUND PERSONNEL AND BYSTANDERS

A

Be alert to others in the work area. Be sure others know when and where you **will** be working. Make sure no one is behind equipment or within 20 feet of it operating.

Loose fitting clothing, long hair, jewellery and equipment which might become entangled in moving equipment are prohibited while working near Auger Drills or Anchoring equipment.

Operators, helpers, and other personnel working near Auger Drills or screw piling equipment must wear steel toe safety shoes, safety glasses, and hard hats as a minimum. Hearing protection, respirators, and personnel protective clothing **will** be specified in the site specific Health and Safety Plan.

WARNING MAINTAINING THE PLANETARY DRIVE

A

Before performing maintenance, lower the attachment to the ground, apply the parking brakes, turn off the engine, and remove the key.

Drill rigs must be shut down and properly locked out and tagged before repairs or maintenance is performed. Only properly trained and qualified individuals are permitted to perform repairs and maintenance.

Never adjust a relief valve for pressure higher than recommended by the machine's manufacturer.

WARNING TRANSPORTING

A

Follow all local government regulations that may apply along with recommended tie down points and any equipment safety precautions at the front of this handbook when transporting your attachment.

WARNING TIE DOWN POINTS

A

Tie down points are identified by tie down decals where required. Securing to trailer at other points is unsafe and can damage attachment.

Do not attach tie down accessories around cylinders or in any way that may damage hoses or hydraulic components.

Attach tie down accessories to unit as recommended.

Check unit stability before transporting.

Verify that all tie down accessories (chains, slings, ropes, shackles and etc.) are capable of maintaining attachment stability during transporting and are attached in such a way to prevent unintended disengagement or shifting of the unit. Failure to do so could result in serious personal injury or death.

TO THE OPERATOR

The primary responsibility for safety with this equipment falls to the operator. Make sure that the equipment is operated only by trained individuals that have read and understand this manual. Don't hurry the learning process or take the unit for granted.

It is the skill, care, common sense, and good judgement of the operator that will determine how efficiently and safely the job is performed. Know your equipment before you start. Know its capabilities and how to operate all the controls.

Visually inspect your equipment before you start, ensure correct assembly and installation of the attachment and never operate equipment that is not in proper working order.

Practice the operation of your new attachment and become familiar with the controls and the way it handles on your machine. If there is any portion of this manual or function you do not understand, contact your local authorized dealer or the manufacturer.

1. Never operate the Attachment without first reading and understanding the entire operator's manual.
2. Do not paint over, remove or deface any safety signs or warning decals on your equipment.
3. Follow all safety decals. Keep them clean and replace them if they become worn, damaged or illegible.
4. Know your equipment inside and out. Know how to operate all controls and know emergency shut down procedures.
5. Keep all stepping surfaces, pedals, and controls free from dirt, grease and oil. Keep equipment clean to help avoid injury from slipping or a fall when getting on or off equipment.
6. Operate the attachment only in daylight or with sufficient artificial light.
7. Always carry loads close to the ground. Do not step off machine platform with load raised.
8. Turn off engine before performing maintenance. All maintenance can be performed with the machine arms lowered. If lift arms must be left raised for any reason, use a positive lift arm lock to secure the arms in place. Serious damage or personal injury could result from lift arms accidentally lowering.
9. Do not exceed rated operating capacity of the host machine, as machine may become unstable resulting in loss of control.
10. Always lower the loader arms or machine boom to the ground, shut off the engine and remove the key before getting off the unit.
11. Never use the Drive Unit on a machine that is not equipped with a cab or ROPS, and operator restraints (seat belts or equivalent devices).

6 SAFETY - WORKING WITH THE ATTACHMENT

WHEN DEALING WITH HYDRAULICS DURING ANY TYPE OF ASSEMBLY, OPERATION, MAINTENANCE, OR OTHER WORK ON OR NEAR THIS PRODUCT

Hydraulic fluid under pressure can penetrate the skin and cause serious injury or death. Hydraulic leaks under pressure may not be visible.

If any fluid penetrates the skin, GET IMMEDIATE MEDICAL ATTENTION.

Wear safety glasses, protective clothing, and use a sound piece of cardboard or wood when searching for hydraulic leaks. DO NOT USE YOUR HANDS.

Before connecting or disconnecting hydraulic hoses, read your machine or power unit's operator's manual for detailed instructions on connecting and disconnecting hydraulic attachments.

Make certain that all parts meet the specifications for this product when installing or replacing hydraulic hoses or fittings.

After connecting hydraulic lines:

- o Slowly and carefully raise the loader's arm/s and cycle the rollback/ dump cylinders to check hose clearances and to check for any interference.
- o Operate the hydraulics on this product to ascertain forward and reverse.
- o Make certain that the hoses cannot interfere with or actuate the quick attach mechanism.
- o Make certain that hoses will not be pinched, or get tangled, in any equipment.

Do not lock the auxiliary hydraulics of your power unit in the ON position.

Refer to your power unit's operator's manual and this manual for procedures and intervals, then inspect and maintain the entire hydraulic system to insure that the fluid remains clean, that all devices function properly, and that there are no fluid leaks.

WHEN MOUNTING THIS PRODUCT TO YOUR MACHINE

Refer to the operator's manuals of your machine, and your quick attach for special or detailed mounting instructions.

This product should fit onto the quick attach Frame or Hitch (Machine Mount).

If this product does not fit properly, contact your Blue Diamond Dealer before operating.

Never place any part of your body into the mounting plate, frame, hitch or loader holes. A slight movement of the power unit and this product could cause serious injury.

Where Dead Man connections are connected or installed, do not disengage, tamper with or remove them.

WHEN ADJUSTING, SERVICING OR REPAIRING THIS PRODUCT

Make no modifications to your Drive Unit.

When making repairs use only authorized Blue Diamond service agents, use only genuine Blue Diamond parts for the gearbox. For fasteners, hydraulic hoses, or hydraulic fittings, use only properly rated parts.

Replacement parts must also have safety signs attached.

6 SAFETY DECAL LOCATION

GENERAL INFORMATION

The following decals are reductions of the actual decals used on auger drives. Use this information to order replacements for lost or damaged decals. Be sure you understand all decals before operating the attachment. They contain information you need to know for attachment safety.

IMPORTANT

Keep all safety decals clean and legible. Replace all missing, or damaged safety decals. When replacing parts with safety decals attached, the safety decals must also be replaced.

REPLACING SAFETY DECALS

Clean the area of application with a nonflammable solvent, then wash the same area with soap and water. Allow the surface to dry. Remove the backing from the safety decal, exposing the adhesive surface. Apply the safety decal to the position shown in the diagram, and smooth out any bubbles.

DECAL LOCATION

Safety / Warning decals should be placed on each side of the drive unit facing any bystanders.

ORDERING NEW DECALS

Contact your local Blue Diamond Attachments dealer to obtain new safety decals as well as logo and model decals.



The key feature of your Blue Diamond Attachments Auger Drive is low maintenance, regular oil changes only are required. It contains no user serviceable parts, unauthorized disassembly will void warranty. WRITTEN PERMISSION FROM BLUE DIAMOND ATTACHMENTS MUST BE OBTAINED before performing any disassembly.



SAFETY FIRST READ AND UNDERSTAND THE SAFETY INSTRUCTIONS BEFORE BEGINNING ANY DRIVE UNIT MAINTENANCE.

BEFORE FIRST USE

Inspect the attachment for shipping damage. If damage does exist, do not operate until the damaged parts have been replaced or repaired.

BEFORE EACH USE

Make sure that all nuts and bolts are in place and properly tightened.

Make sure that all other fasteners are in place and are performing their specified function.

Make sure that all hydraulic fittings are tightened and that there are no leaks in any fittings or hoses.

Make sure that all safety signs are in place, are clean, and are legible. (SEE THE SAFETY SIGN SECTION)

Check for any oil leaks.

Wear and tear on pins, linkages, clips, bushes and hood.

Ensure any damage or excessively worn parts are replaced.

Always wear safety goggles or glasses when inspecting equipment.

WARNING!

If injured by injected fluid, see a doctor at once. If your doctor is not familiar with this type of injury, ask him to research it immediately to determine proper treatment.

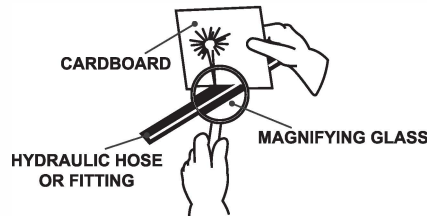

Escaping fluid under pressure can have sufficient force to penetrate the skin causing serious personal injury. Fluid escaping from a very small hole can be almost invisible. Use a piece of cardboard or wood, rather than hands to search for suspected leaks. Keep unprotected body parts, such as face, eyes, and arms as far away as possible from a suspected leak. Flesh injected with hydraulic fluid may develop gangrene or other permanent disabilities.

OPERATING PARAMETERS

The hydraulic motor of your auger drive unit has a maximum power rating. Maximum Pressure & Max Flow cannot be achieved at the same time. Ensure you know and understand the maximum flow, pressure and power ratings of your auger drive and machine and never exceed the maximum ratings listed below. The following charts indicate the maximum capacities of the drive unit.

MODEL	PRV	ECV	Case Drain	MAX POWER		MAXIMUM FLOW		MAXIMUM PRESSURE	
				HP	Kw	GPM @ PSI		PSI @ GPM	
MS1	N/A	Opt	Opt	20	15	15	2300	3000	11
EX1	N/A	Opt	Opt	33	25	30	1800	3500	16
EX2	N/A	Opt	Opt	33	25	30	1800	3500	16
EX3	N/A	Opt	Opt	33	25	30	1800	3500	16
EX4	N/A	Opt	Opt	33	25	30	1800	3500	16
EX4HF	Inc	Opt	Opt	55	41	42	3100	3500	27
EX5HF	Inc	Opt	Opt	55	41	55	1700	3500	27
EX6HF	Inc	Opt	Opt	55	41	55	1700	3500	27
EX7HF	Inc	Opt	Opt	55	41	55	1700	3500	27
EX9HF	Inc	Opt	Opt	60	45	55	1800	3500	29
EX12HF	Inc	Opt	Opt	60	45	55	1800	3500	29
EX13HF	Inc	Opt	Opt	67	50	61	1800	3500	33
EX16HF	Inc	Opt	Opt	67	50	61	1800	3500	33
EX20HF	Inc	Opt	Opt	67	50	61	1800	3500	33
EX25HF	Inc	Opt	Opt	67	50	61	1800	3500	33
EX30HF	Inc	Opt	Opt	67	50	61	1800	3500	33

MODEL	PRV	ECV	Case Drain	POWER		MAXIMUM FLOW		MAXIMUM PRESSURE	
				HP	Kw	GPM@PSI		PSI@GPM	
2 SPEED DRIVE UNITS - LOW PRESSURE (3000PSI)									
2EX7LP&2AEX7LP	Inc		Inc	55	41	53	1800	3000	27
2EX9LP&2AEX9LP	Inc	2EXLP Opt/2AEXLP Inc	Inc	60	45	53	1950	3000	29
2EX12LP &2AEX12LP	Inc	2EXLP Opt/2AEXLP Inc	Inc	60	45	53	1950	3000	29
2EX16LP &2AEX16LP	Inc	2EXLP Opt/2AEXLP Inc	Inc	67	50	53	2200	3000	33
2EX20LP &2AEX20LP	Inc	2EXLP Opt/2AEXLP Inc	Inc	80	60	53	2600	3000	39
2EX25LP &2AEX25LP	Inc	2EXLP Opt/2AEXLP Inc	Inc	80	60	53	2600	3000	39
2 SPEED DRIVE UNITS - STANDARD PRESSURE (3500PSI)									
2EX5HF &2AEX5HF	Inc	DDT Opt/ADT Inc	Inc	55	41	53	1800	3500	27
2EX6HF & 2AEX6HF	Inc		Inc	55	41	53	1800	3500	27
2EX7HF&2AEX7HF	Inc	2EXHF Opt/2AEXHF Inc	Inc	55	41	53	1800	3500	27
2EX9FH &2AEX9HF	Inc	2EXHF Opt/2AEXHF Inc	Inc	60	45	53	1950	3500	29
2EX12HF &2AEX12HF	Inc	2EXHF Opt/2AEXHF Inc	Inc	60	45	53	1950	3500	29
2EX13HF & 2AEX13HF	Inc	2EXHF Opt/2AEXHF Inc	Inc	67	50	53	2200	3500	33
2EX16HF & 2AEX16HF	Inc	2EXHF Opt/2AEXHF Inc	Inc	67	50	53	2200	3500	33
2EX20HF &2AEX20HF	Inc	2EXHF Opt/2AEXHF Inc	Inc	80	60	53	2600	3500	39
2EX25HF & 2AEX25HF	Inc	2EXHF Opt/2AEXHF Inc	Inc	80	60	53	2600	3500	39
2EX30HF &2AE30HF	Inc	2EXHF Opt/2AEXHF Inc	Inc	80	60	53	2600	3500	39

COMMISSIONING PROCEDURE



NOTE: BEFORE THE DRIVE UNIT IS EVEN CONNECTED TO THE MACHINE ENSURE THAT THE DRIVE IS FULL OF HYDRAULIC OIL AND THE GEARBOX IS FULL OF GEAR OIL.

All Blue Diamond Attachments planetary drive units are dispatched from the factory full of fluids (hydraulic and gearbox oil) unless this warning decal is attached.

The decal is only applied in special circumstances, for example if a drive unit needs to be air freighted to the customer. Air transportation regulation prohibits certain fluids from being air freighted.

If there are no fluids in the drive unit at the time of dispatching, then the decal will be applied to the drive unit.

1. Once you have determined if the drive unit has gearbox oil in or requires oil, ensure that the correct grade and quantity of oil is used. **DO NOT RUN THE DRIVE UNIT WITHOUT OIL.** Connect the hydraulic hoses and if required, optional 2 speed electrical harness to the machine. If the customer has ordered the optional Pressure Differential Kit and the align Kit, then there will be 2 additional electrical harness to connect.



2. 2 speed drives fitted with an Eaton VIS motor requires a case drain. The case drain hose is already fitted to the hydraulic motor and needs to be connected to the hydraulic line which returns to the hydraulic tank of the excavator.



NOTE: IF REQUIRED, ENSURE THAT THE CASE DRAIN HOSE IS CONNECTED TO THE RESERVOIR OF THE MACHINE. IT IS IMPORTANT THAT THE PRESSURE IN THE CASE DRAIN HOSE IS NOT READING MORE THAN 1 PSI WHILST OPERATING AND THAT A CONSISTENT TRICKLE OF HYDRAULIC OIL IS BEING RETURNED TO THE EXCAVATOR RESERVOIR. INTERMITTENT AND SPURTS OF FLOW FROM THE CASE DRAIN HOSE ARE NOT STANDARD DESIGN SYMPTOMS. PLEASE CONSULT A BLUE DIAMOND DEALER OR BLUE DIAMOND® SERVICE IF THIS OCCURS.



NOTE: TO ENSURE BEST MOTOR LIFE, RUN MOTOR FOR APPROXIMATE ONE HOUR AT 3/4 OF RATED PRESSURE BEFORE APPLICATION TO FULL LOAD. BE SURE THAT MOTOR AND GEARBOX ARE FULL OF FLUIDS PRIOR TO ANY LOAD APPLICATION.

ALL PLANETARY GEAR DRIVE UNITS UP TO EX3 HF/AEX3 HF US CHEVRON MEROPA ISO 32 (MINERAL OIL) gearbo oil for operating in tropical ambient temperatures. See maintenance section in the operators manual on gearbo oil level checking as well as the gearbo oils recommended for cold climate conditions. Blue Diamond® produces many drive units with many different gear set ratios and as a result don't list every possible gearbo option and gearbo oil quantity required. See the maintenance section for gearbo volume and checking/topping up the gearbo oil.



NOTE: WHEN PROCURING ANY HOSE ASSEMBLIES FOR USE ON YOUR BLUE DIAMOND® ATTACHMENTS PLANETARY DRIVE UNIT ENSURE THAT THE MAX OPERATING PRESSURE OF THE HOSES IS ALWAYS HIGHER THAN WHAT THE EXCAVATOR OR MACHINE (WHICH THE PLANETARY DRIVE UNIT WILL BE USED ON) CAN PRODUCE.

COMMISSIONING PROCEDURE

INSTALLING YOUR HIGH PERFORMANCE PLANETARY DRIVE

1. Remove the shipping banding from around the attachment.
2. ENSURE YOU HAVE READ THE SERIAL TAG ON THE DRIVE UNIT TO OBTAIN THE MAX FLOW AND PRESSURE RATINGS. Ensure your machine flow and pressure settings are aligned with the requirements of the drive unit. NEVER EXCEED THE MAX FLOW AND PRESSURE RATINGS AS WARRANTY WILL BE VOID.
3. Following all standard safety practices and the instructions for installing an attachment as shown in your machine operator s manual.
4. Lower the unit to the ground and remove any attachments from the front of the host machine.
5. Attach the quick attach mounting frame or hitch to the host machine as per the machine manufacturers specifications. Ensure the locking mechanisms on the machine are engaged the attachment is secure.



NOTE: IT IS IMPORTANT TO MAKE SURE THE LOCKING MECHANISM ON YOUR QUICK ATTACH IS ENGAGED, THEREFORE LOCKING THE ATTACHMENT ONTO THE MACHINE.

6. Relieve any pressure from the auxiliary hydraulic system and after making sure there is no foreign matter on the hydraulic quick couplers, connect the power and return quick couplers to the auxiliary hydraulic system of your machine. The list below shows the most common places to tap into the hydraulic system on various types of machines.

SKID STEER LOADERS Auxiliary hydraulic outlets.

BACKHOES EXCAVATORS Auxiliary hydraulic outlets or bucket curl cylinder circuit.

WHEEL LOADERS Auxiliary hydraulic outlets or bucket lift (dump) cylinder circuit.

7. If applicable connect the case drain coupler to the case drain on your machine. If your machine has a case tap, ensure the case tap is open. Failure to connect the case drain will severely damage the motor and void all warranty. Case Drain hose is already fitted to the units Hydraulic motor and must be unravelled. This Case drain hose must return directly to Hydraulic Oil Reservoir on the Parent machine. There can be no valving or restrictions in the line and the hose must be minimum 1/2 ID. The loose end of this case drain line must have a fitting fitted to match the fitting on the parent machine.



WARNING: ENSURE THAT THERE ARE NO QUICK RELEASE COUPLERS IN THE CASE DRAIN LINE OR THE T CONNECTORS. OPERATION WITHOUT CASE DRAIN WILL CAUSE MOTOR FAILURE

8 COMMISSIONING PROCEDURE

8. **VARIABLE FOOT CONTROL** Excavators used to power Drive units must have their Auxiliary Circuit controlled with a variable foot control. This foot control gives the operator the ability to ease the power on and off avoiding shock loading which will cause potential expensive damage to the Hydraulic motor and Gearbox.
9. **FILTRATION/CONTAMINATION** These units are fitted with a hydraulic motor, therefore require the oil to be of suitable cleanliness. Ensure hoses are clear of any contamination during connecting/disconnecting to prevent contaminants entering the hydraulic motor.
10. With the unit lying horizontally on the ground connect the auger, screw anchor or extension or core barrel. **ENSURE THE AUGER BOLT AND NUT ARE INSTALLED CORRECTLY.** The machine is now ready for use.

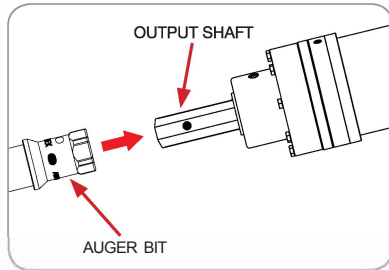

1. Tilt the drilling drive up so the output shaft is at the appropriate angle needed to install the auger bit.

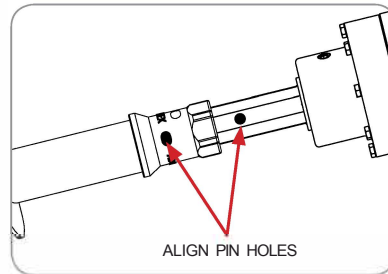

2. Raise the auger to align the pin holes in the auger bit with the drilling drive output shaft. Slide the auger onto the shaft until the holes align.

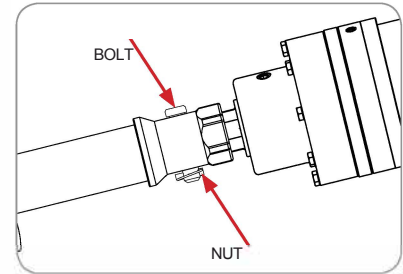

3. Insert the bolt through the auger bit and the output shaft. Secure with nut.

11. If augering, check the auger teeth and pilots are not worn. Ensure all worn parts are replaced. Worn parts will become ineffective and severely diminish the overall performance of the Planetary Drive and Auger.

PLEASE NOTE: ALTERING, TAMPERING OR DISMANTLING ANY PART OF THE BLUE DIAMOND UNIT WITHOUT WRITTEN PERMISSION FROM BLUE DIAMOND WILL VOID ANY WARRANTY.

9 OPERATING INSTRUCTIONS COLD WEATHER STARTUP

COLD WEATHER STARTUP INFORMATION

The information that is contained on this page is an aid to the operation and maintenance of your Blue Diamond Attachments planetary Drive Unit in cold weather. When you operate the host machine in temperatures from 9 C (4 F) to 4 C (4 F) refer to the Operation and Maintenance Manual of your machine. It is difficult to outline the operation and maintenance of a machine that is used in freezing temperatures for a general publication. The difficulty in outlining the requirements is caused by the following conditions:

- The unlimited differences in weather conditions
- Applications and ground conditions
- And the supplies that are available in your area

In order to provide the best possible guidelines, use the information in this document and the following criteria: varying factors, recommendations from your Machinery dealer, and past proven practices.

HINTS FOR COLD WEATHER

Make sure that you read the information for selecting the correct oils for use in cold weather. Refer to page 44 for detail. Prepare the machine for the weather conditions as instructed in your machines operator manuals.

PROCEDURE FOR STARTUP IN COLD WEATHER

- Your Blue Diamond Attachments Planetary Drive System is designed to operate within air temperature of 5 C (41 F) and 3 C (6 F). For temperatures below 5 C (4 F) it is recommended to slowly start the drive under no load, at minimum speed. This will allow warm hydraulic oil from your host machine to circulate through the hydraulic motor of your drive and slowly bring it to the minimum recommended operating temperature of 5 C (4 F). Once the minimum temperature has been achieved it is recommended to slowly introduce load to the output of the drive unit, which in turn will increase the internal gear oil temperature.

N.B. The host machines cooling system and the lubrication system for the engine do not lose heat immediately upon shutdown. The transmission and the hydraulic system lose heat more rapidly because of more exposed areas. The Planetary Gearbo Motor cases cool rapidly, since the cases do not operate as warm as other compartments. Therefore, after any period of down time on the machine, ensure you achieve full operating temperatures through following start up instructions. Thick oil can also cause high case pressures which in turn cause shaft seal problems.

OPERATING PROCEDURES -AUGERING



YOUR BLUE DIAMOND HIGH PERFORMANCE PLANETARY DRIVE IS SPECIFICALLY DESIGNED FOR DRILLING AND ROTATIONAL OPERATION ONLY, IT IS NOT A LIFTING DEVICE

INTENDED USE

This unit is designed for drilling vertical or horizontal holes or rotating piers into the ground. Use in any other way is considered contrary to the intended use.

After all installation instructions have been completed, safety information read and understood, and the rest of this operator's manual has been reviewed, your Blue Diamond Attachments Auger is now ready for use.

1. With the auger bit raised off the ground and the vehicle engine set at a low RPM, activate the host machine's drive control valve to determine which position the control valve lever must be in to turn auger in a forward (clockwise) rotation. This is the digging position.
2. Before beginning to dig, experiment with auger speed to determine a suitable auger RPM. Generally in light and sandy soil a high RPM is desirable. In hard, rocky, or frozen soils a slower RPM is desirable. To increase auger RPM, increase vehicle engine RPM. To decrease auger RPM, decrease vehicle engine RPM.
3. Raise the Auger Drive so the auger bit hangs vertical and the drive is clear of the cradle, then lower the auger into the starting position.
4. Ensure the crowd on your machine is forward and not back. This will keep the Drive clear of the cradle and allow the auger to move freely from side to side and forward and back. The pendulum action must not be hindered otherwise damage / bending of the shaft or auger may occur. Lower the auger into the ground ensuring the auger drive does not stall and remains in a vertical position, start rotation of the auger.
5. As the auger starts to load up with spoil, stop the rotation whilst still in the hole and raise the auger vertically. Move away from the hole, rotate the auger stop, rotate the auger stop in the forward direction to remove the spoil. DO NOT rapidly engage forward/reverse action to remove spoil.



DO NOT RAPIDLY ENGAGE FORWARD REVERSE OPERATION TO REMOVE SOIL FROM THE AUGER, THIS CREATES EXCESSIVE PRESSURE SPIKES WHICH WILL ADVERSELY EFFECT PERFORMANCE AND LONGEVITY OF THE MOTOR

6. Do not remove the auger on an angle out of the hole, as you will run the increased risk of bending the auger or shaft.
7. If trying to remove the auger full of material and you experience strong resistance, reverse the auger slowly whilst raising the auger vertically to assist with removal. Do not pull with the machine as you may run the risk of shaft damage to the drive.
8. Do not flick the dirt (especially mud or clay) from the auger, as you may run the increased risk of bending the auger shaft.
9. Keep clearing the auger hole regularly as you drill deeper. This will help prolong the life of the auger and the wear parts.
 Note In rock it is recommended to add a slow stream of water to help the performance and life of the rock teeth.

Excavators Apply the greatest amount of down force from the main boom. Be aware that the boom moves in an arc and to maintain a plumb drilling position, you will need to compensate for this movement by adjusting the dipper arm or moving your machine backwards or forwards to ensure you are drilling straight. You must take extreme care when doing this to prevent the auger or screw pile from bending or pulling flights against the inside of the hole.

All other machines Ensure the vertical position is maintained when drilling.



DO NOT drill with the Cradle resting against the Drive Unit. This will damage your Drive unit Auger.

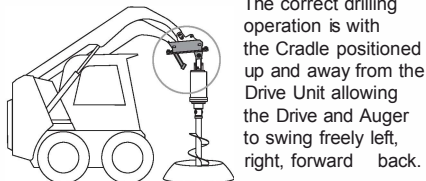

The correct drilling operation is with the Cradle positioned up and away from the Drive Unit allowing the Drive and Auger to swing freely left, right, forward back.

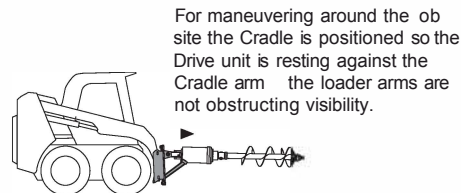

For maneuvering around the job site the Cradle is positioned so the Drive unit is resting against the Cradle arm the loader arms are not obstructing visibility.

EXTENSIONS & TELESCOPIC AUGER EXTENSIONS - OPERATING PROCEDURE

1. Once you have obtained the maximum depth with the extension auger you have, raise the auger out of the hole clear the spoil from the auger. Place the auger back into the hole ensuring the auger is bottomed out in the hole the hub of the extension is clear easily accessible, remove the auger pin to disengage the auger drive from the auger.

NOTE: Ensure personal safety at all times, determine if access to the auger hub, once the auger is in the hole, is safe, if not safe for persons assisting, place boards or covers across the hole before attempting to reach across to the hub.

Install the additional extension onto the auger drive with pin safety clip, lower the extension attach to the auger with second pin safety clip. Always ensure persons assisting are clear visible to the operator at all times.

2. Recommence drilling, Once you have reached the maximum depth, raise the auger and extension out of the hole until the eyelets of the extension are visible just above the hole. Slide the two support bars through the two heavy duty eyelets or U brackets welded to the outer extension. Then remove the pin section of extension and place away from the hole. Then re pin back to the bottom section, take the weight of the rest of the extension auger on the machine remove the support bars. Clear the auger then keep repeating these steps.
3. For telescopic extensions, use the same method as above, but slide the inner extension back into the auger pin.

BLUE DIAMOND DOES NOT ACCEPT ANY LIABILITY FOR INJURY OR DAMAGE RESULTING FROM THE OPERATOR USING THE EXTENSION(S) OUTSIDE THE DESIGNED OPERATING PROCEDURE

OPERATING PROCEDURES - SCREW ANCHORING (PILE/PIER)

1. Installation is to be performed by a trained and/or certified installer.
2. Connect the manufacturer's approved adapters to the Planetary Drive head. If you have two speed operation, start installation in the high speed, low torque setting and start installing pile. As the pressure builds the torque increases, change the two speed controller to High Torque low speed and complete the pile installation to your required depth and torque. If your drive is single speed install the pile in one continuous motion until the desired depth and torque is achieved.
3. Install pile/pier with a continuous motion. The rate should match the pitch on the pile. Make sure to apply just enough downward pressure to help the advancement of the pile into the ground, but not to much that you are driving or drilling the pile into the ground. Always maintain a plumb line so that you do not bend the pile.

All 2 stage reduction Model drives (EX9HF-EX30HF) specified for Anchoring applications must be fitted with an ECV Energy Control Valve (Patented). During the screw anchoring process energy builds up in the pile/pier, when the operator stops installation as torque is reached, the pile/pier temporarily flicks back or rotates back forcing energy up the pile/pier, back up through the gearsets and into the motor, momentarily turning the motor into a pump. The ECV is designed to protect the motor from this action and essentially grabs the oil and gently bleeds it back down the hydraulic lines. The sound it makes is a gentle swoosh, this is how you know the valve is working.

NOTE: Inefficiencies occur with machinery that can reduce the torque output, such as heat, cold, age of machine etc... It is therefore highly recommended that Torque monitoring equipment to keep record of the torque and pressure is installed. Contact Blue Diamond Attachments or your local Blue Diamond Attachments Dealer for further information regarding torque monitoring options.

IT IS THE RESPONSIBILITY OF THE INSTALLER TO CORRECTLY CALCULATE, PLAN AND EXECUTE THE INSTALLATION OF THE PIERS TO THE NOMINATED TORQUES REQUIRED. BLUE DIAMOND ATTACHMENTS DOES NOT ACCEPT ANY LIABILITY OR CONSEQUENTIAL LOSS THAT IS INCURRED FROM INCORRECT INSTALLATION, OVER TORQUING OR UNDER TORQUING OF PILES

OPTIONAL EXTRA - SCS

If you have purchased a Swing Control System please ensure you read and understand the following operational procedures.

STOWED TRAVEL
POSITION FOR
SKID STEERS & EXCAVATORS

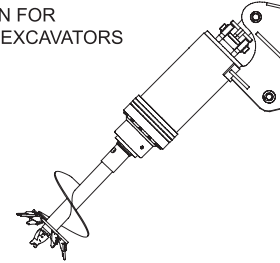

LEFT TO RIGHT
OPERATING RANGE

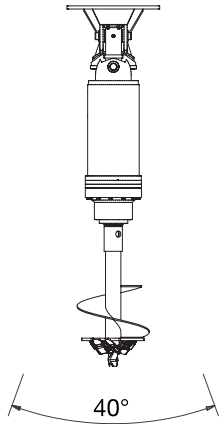

SAFE OPERATING RANGE

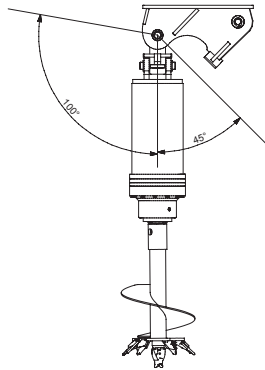

DRILL HEAD IS IN
STOWED POSITION
DO NOT OPERATE
IN THIS POSITION

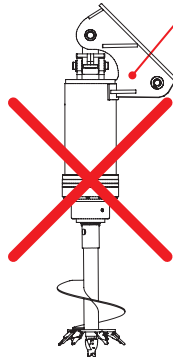

DRILL HEAD IS LOCKED
DO NOT OPERATE
IN THIS POSITION
UNIT WILL BE DAMAGED

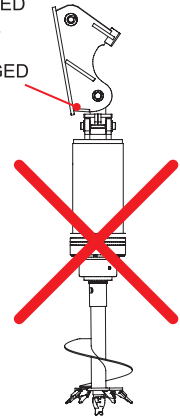

OPTIONAL EXTRA - RYNO HITCH

If you have purchased a Ryno Hitch please ensure you read and understand the following operational procedures

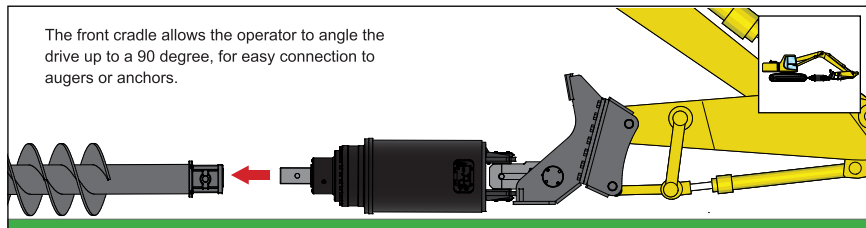
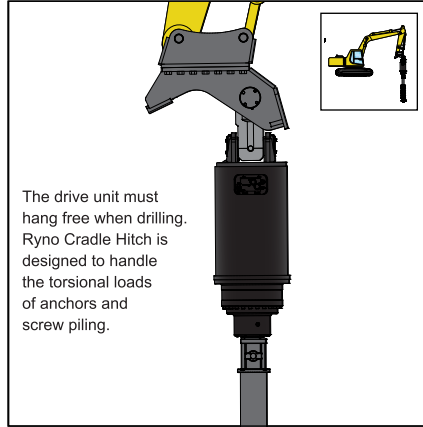
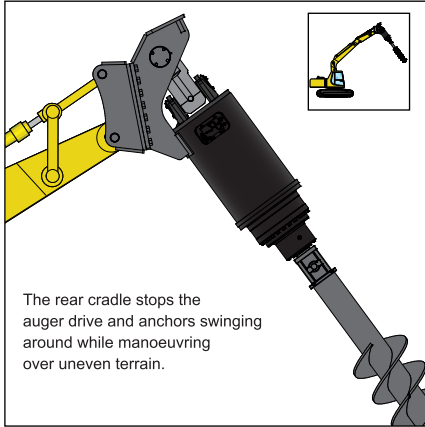

AVOID PILE INSTALLATION WHEN HITCH IS FULLY UP

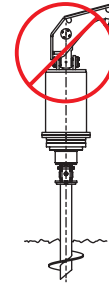

AVOID PILE INSTALLATION WHEN HITCH IS FULLY DOWN

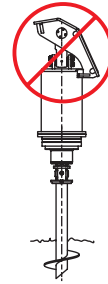

PILE LOADING

DURING PILE LOADING, MAKE SURE THAT THE LINKAGE IS IN LINE WITH THE PILE BEFORE STARTING THE CROWDING OR LIFTING ACTION. FAILURE TO DO SO MAY LEAD TO DAMAGE.

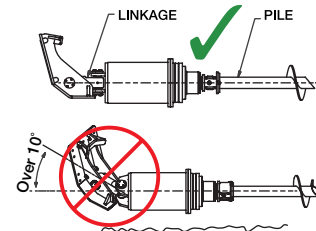

(i) 2-speed Drives

Note: The 2-speed Drive can be supplied in either a 12V or 24V system as per customer request.
There are 2 ways to electrically power the drive unit:

1) HARD WIRE FROM THE MACHINE BATTERY:-

12 Volt Excavator connection diagram to 12V 2-speed Drive Unit

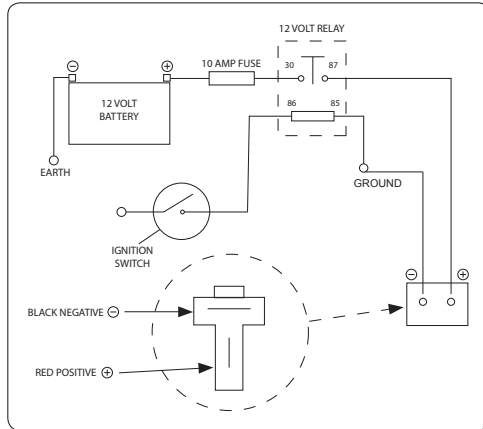

Connect pin 30 of relay via 10 amp fuse to battery.
Connect pin 86 of relay to an ignition source.
Connect pin 85 to a ground.
Connect pin 87 of relay to two pin plug to connect to 2-speed controller harness. (This connection point is tagged "supply").
Connect a ground to the two pin plug to connect to 2-speed controller harness.

24 Volt Excavator connection diagram to 24V 2-speed Drive Unit

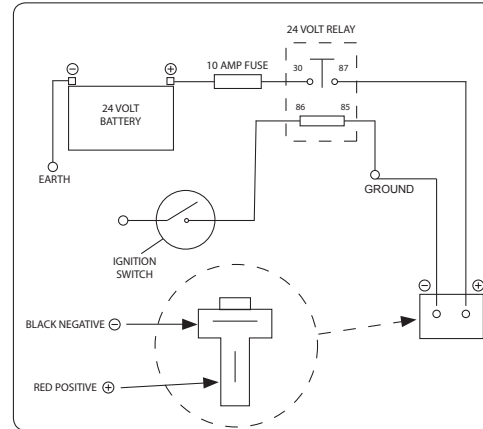

Connect pin 30 of relay via 10 amp fuse to battery.
Connect pin 86 of relay to an ignition source.
Connect pin 85 to a ground.
Connect pin 87 of relay to positive terminal of the 2 pin plug.
Connect a ground to the two pin plug to connect to 2-speed controller harness.

10 TWO SPEED ELECTRICS INSTALLATION

2) USE OF THE CIGARETTE LIGHTER POWER LEAD

Power lead (B) 205914 comes included in the Plug and Go 2-Speed Controller Kit which is recommended for telehandlers, backhoes and excavators as well as skid steer loaders (without a service plug). 4 kits are available with 4 different length extension harnesses.

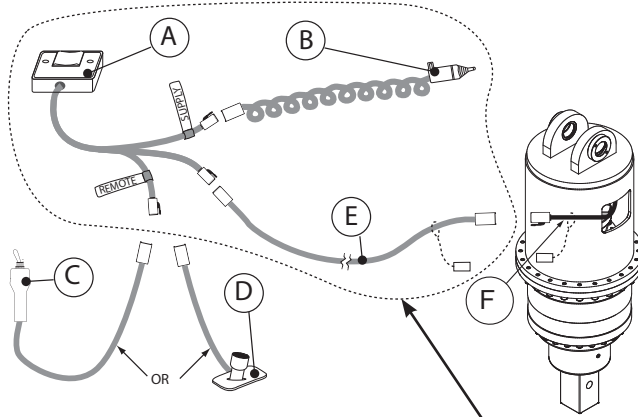

- If the planetary drive unit is fitted with 24V Solenoid coil, plug cigarette lighter plug into 24V DC Socket.
- If the planetary drive unit is fitted with a 12V solenoid coil, plug cigarette lighter plug into 12V DC socket.
- **Do not connect A 12V powered drive unit to a 24V supply.**

ITEM	DESCRIPTION
A	Controller 2-Speed
B	12V/24V Power Lead
C	Remote Toggle Switch (OPTIONAL)
D	Remote Floor Mounted Switch (OPTIONAL)
E	Extension Harness - Choose length
F	1 ft Harness standard with 2 speed drive

PLUG AND GO KITS

KIT PART NUMBER	BOOM EXTENSION HARNESS LENGTH	TO SUIT MACHINE (SUGGESTED)
205900	3M (10FT)	UP TO 5T EXCAVATORS
205901	6M (20FT)	5T TO 8T EXCAVATORS & SKID STEER LOADERS
205902	12M (40FT)	8T TO 16T EXCAVATORS
205903	15M (50FT)	18T + EXCAVATORS

(ii) 2 Speed Drives (Powered by EATON VIS motors)

(iii) Single Speed Drives (SAI TF 2.5 / EATON 2K and 6K series motors) Do not require electrics.

CONNECTING THE OPTIONAL 2-SPEED HARNESS KIT TO AN EXCAVATOR, TELEHANDLER OR BACKHOE

The drive unit is connected to the 2-Speed controller (mounted in the Cab) via an extension harness.

(This harness contours the hydraulic hoses on the boom of an excavator). The extension harnesses are available in 9.8', 19.7', 39.4' or 49.2' length. The boom harness can be attached to the hydraulic lines of the excavator using cable ties. (See illustration on the following page)

The Optional Electrical 2 Speed Harness Kit Comprises the Following:

1x extension harness. (the extension harness is available in 4 different lengths 9.8', 19.7', 39.4' or 49.2' dependent on machine size.)

See illustration on page 34

1x 2-speed controller (part number 205911). This controller has a 4.9' long harness terminated with a 4 pin female Deutsch plug.

(See illustration on the following page).

1x12V/24V power lead (part number 205914)

The controller plugs into the extension harness and the extension harness plugs into the deutsch plug on the motor harness. The motor harness (205910) is connected inside the hood to the hydraulic motor (at the factory).

On the harness of the 2-speed controller and approximately 6 inches from the Deutsch Plug are two plastic 2-pin plugs. The male plug is tagged showing "SUPPLY 12V/24V" and is the main point where power is supplied to the 2-speed system. The other plastic 2-pin plug is a female plug that is tagged "REMOTE". It is this plug that an Optional 2-speed joystick mounted toggle switch (part number 205912) OR Floor Mounted Dipswitch (part number 205913) can be plugged into. (See illustration on following page).

OPERATION OF THE 2-SPEED

1. The speed controller (mounted in the excavator cab) is a 2-speed unit. This allows the operator to select the optimum speed required for drilling, core barrelling or applying screw pylons into the terrain.
2. HIGH SPEED is low torque - LOW SPEED is high torque. (See the torque chart supplied with your drive unit to read, output RPM and corresponding torque at an applied hydraulic pressure.)

10 TWO SPEED ELECTRICS INSTALLATION

2 SPEED ELECTRICAL LAYOUT FOR PD DRIVES USED ON EXCAVATORS, TELEHANDLERS AND BACKHOES

ALL PURCHASED PD 2-SPEED DRIVES INCLUDE

- 10ft motor harness from drive unit

*Boom extension harness, in cab controller with cigarette lighter and power supply sold as separate kits to suit excavator sizes (1)

*Optional Joystick controls and foot controls sold separately (2)

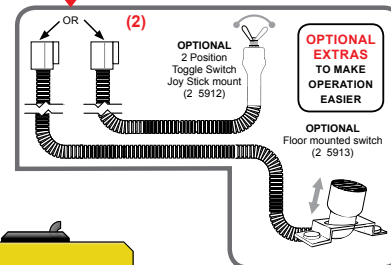
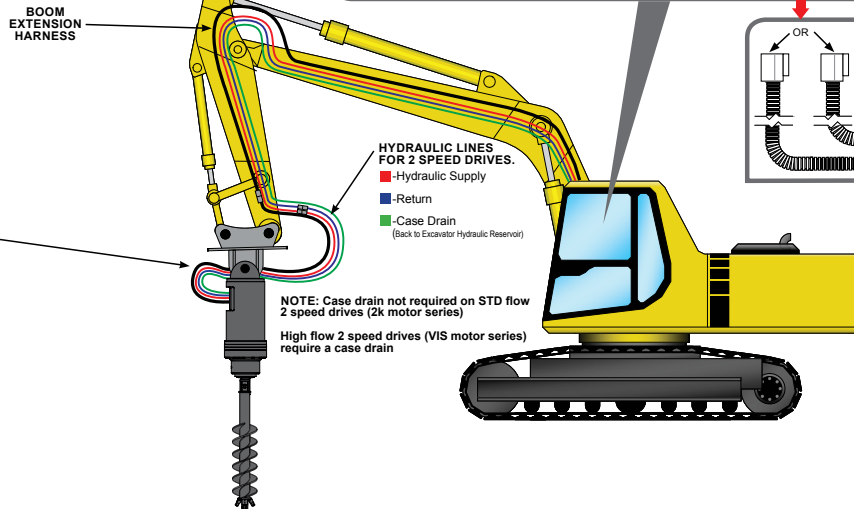
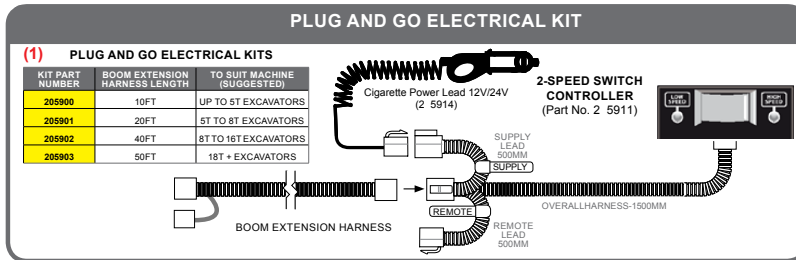

CONNECTING THE 2-SPEED HARNESS TO A SKID STEER LOADER

The drive unit is connected to the two speed controller (mounted in the cab) and connection can be done using either of the two options below:-

1. Direct connection to the loader attachment service plug (optional 8-pin or 14-pin adapter) – see illustration on page 36. In this option depending what service plug the host machine is fitted with (8 pin or 14 pin), the motor harness (205910) will take an adapter plug (216905) or the plug on the motor harness will have to be changed to a 14-pin plug (216902).

OR

2. Connecting using the cab controller, power lead and 3.28' boom extension harness. (These items are optional – see illustration on page 37)

OPERATION OF THE 2-SPEED

1. The 2-Speed DD drive unit range is manufactured using either EATON VIS or Linde hydraulic motors.
2. The speed controller (mounted in the cab) is only used on the Eaton powered drive units. This allows the operator to select the optimum speed required for drilling, core barrelling or applying screw pylons into the terrain.
3. **HIGH SPEED** is low torque - **LOW SPEED** is high torque. (See the torque chart supplied with your drive unit to read, output RPM and corresponding torque at an applied hydraulic pressure.)

10 TWO SPEED ELECTRICS INSTALLATION

2 SPEED ELECTRICAL LAYOUT FOR DRIVES USED ON SKID STEER LOADERS FITTED WITH SERVICE PLUG

ALL PURCHASED 2-SPEED DRIVES INCLUDE

- 10ft harness from drive unit with 2 pin Deutsch plug (2 591) You will need to order an additional harness to fit your machine service plug. See table bottom right of page.

HYDRAULIC LINES FOR 2 SPEED DRIVES.

- -Hydraulic Supply
 - -Return
 - -Electrical Harness
 - -Case Drain *
- (Back to Hydraulic Reservoir)

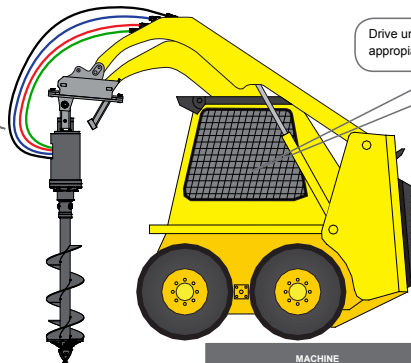

Drive unit speed selection achieved by using appropriate buttons on the machine joystick.

OPTIONAL ADAPTOR HARNESS

216905 INCLUDES

- 2 PIN TO 8 PIN Adaptor WHICH CONNECTS DIRECTLY INTO SUPPLIED HARNESS (2 591)

OPTIONAL ADAPTOR HARNESS KIT

216902 INCLUDES

- 2-PIN TO 14-PIN Adaptor HARNESS
- ELECTRONIC CIRCUIT TESTER
- INSTRUCTIONS HOW TO CONNECT THE 14-PIN PLUG TO THE ADAPTOR HARNESS.

NOTE

WHEN USING A 2 SPEED DRIVE WHICH IS POWERED BY AN EATON VIS HYDRAULIC MOTOR, THE CASE DRAIN HOSE MUST BE CONNECTED.

SERVICE PLUG INFORMATION

A SERVICE PLUG IS AN ELECTRICAL PLUG ON THE FRONT OF SOME SKID STEER LOADERS WHICH IS USED TO ENABLE THE ELECTRICAL FUNCTIONS OF AN ATTACHMENT TO BE CONTROLLED VIA THE MACHINES JOYSTICKS.

THE PLUG CAN COME IN 7, 8 OR A 14 PIN CONFIGURATION DEPENDING ON THE BRAND OF MACHINE. THE TABLE TO THE RIGHT SHOWS WHICH CONVERSION KIT IS REQUIRED FOR WHICH MACHINE.

AS MACHINE MANUFACTURERS SET UP THEIR PINS DIFFERENTLY AND OPERATORS HAVE THEIR OWN PREFERENCES ON HOW THEY LIKE THEIR JOYSTICKS TO WORK BLUE DIAMOND ATTACHMENTS DOES NOT PRE-WIRE THE PLUGS. THE CUSTOMER WILL NEED TO DO THIS. THE PROCESS IS RELATIVELY SIMPLE AS WE SUPPLY THE PARTS AND INSTRUCTIONS ON HOW TO COMPLETE.



MACHINE	ADAPTOR HARNESS REQUIRED (FOR 8-PIN ON MACHINE)	ADAPTOR HARNESS KIT REQUIRED (TO CONVERT TO 14-PIN PLUG FOR MACHINE)
ASV	DM-000032 (optional)	N/A
Bobcat (USING 14 PIN)	N/A	2169 2 (optional)
Bobcat (USING 7 PIN)	Please contact Bobcat OR purchase Plug and Go Kit to bypass service plug (DM-000034)	
CASE (Pre 09/01/01)	2169 5 (optional)	N/A
CASE (Post 09/01/01)	N/A	2169 2 (optional)
CASE (400 series)	N/A	2169 2 (optional)
CAT (pre 2014)	2169 5 (optional)	N/A
CAT (D-series)	N/A	2169 2 (optional)
GEHL	N/A	2169 2 (optional)
JCB	N/A	2169 2 (optional)
John Deere "EH"	N/A	2169 2 (optional)
Komatsu	2169 5 (optional)	N/A
Kubota	N/A	2169 2 (optional)
Mustang	N/A	2169 2 (optional)
New Holland	N/A	2169 2 (optional)
Takeuchi	N/A	2169 2 (optional)
Terex	2169 5 (optional)	N/A
Volvo	N/A	2169 2 (optional)

2 SPEED ELECTRICAL LAYOUT FOR DRIVES USED ON SKID STEER LOADERS NOT FITTED WITH SERVICE PLUG

ALL PURCHASED 2-SPEED DRIVES INCLUDE

- 10ft harness from drive unit with 2 pin Deutsch plug
- **Optional in cab controller with cigarette lighter, power supply and 20ft extension harness sold separately (1)*
- **Optional Joystick controls and foot controls sold separately (2)*

ALL 2-SPEED DRIVES

- 10ft harness with 2 pin male Deutsch plug factory installed in drive unit at time of order
- Re-order Part Number (205910)

HYDRAULIC LINES FOR 2 SPEED DRIVES.

- Hydraulic Supply
 - Return
 - Electrical Harness
 - Case Drain *
- (Back to Hydraulic Reservoir)

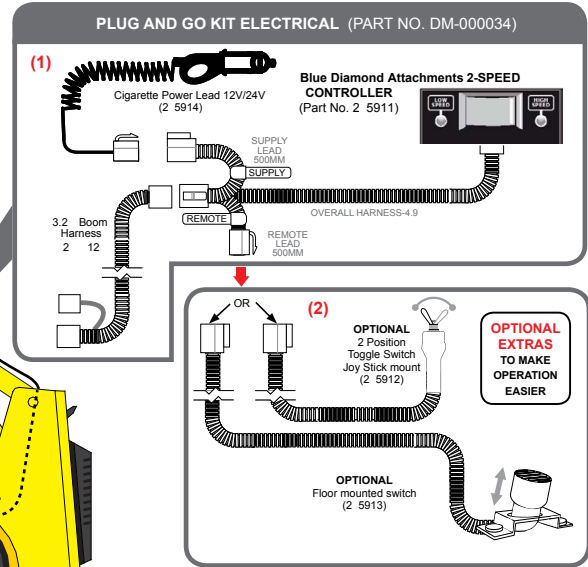
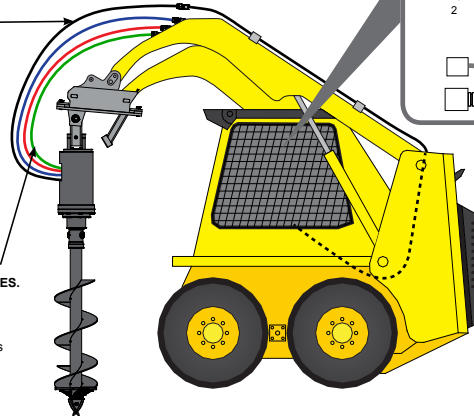

NOTE

WHEN USING A 2 SPEED DRIVE WHICH IS POWERED BY AN EATON VIS HYDRAULIC MOTOR, THE CASE DRAIN HOSE MUST BE CONNECTED.

* NOTE: Case drain not required on STD flow 2 speed drives (2k motor series)

High flow 2 speed drives (VIS motor series) require a case drain to be connected

10 TWO SPEED ELECTRICS INSTALLATION

Electrical and hydraulic schematic drawings:

BELOW IS A COPY OF THE MOTOR HARNESS PART NO. 205910 USED ON 2 SPEED DRIVE UNITS:



NOTE: NO ELECTRICAL HARNESSES OR SPEED CONTROLLERS ARE USED ON SINGLE SPEED DRIVE UNITS

DIN Connector or Hirschmann Plug which connects to the solenoid valve

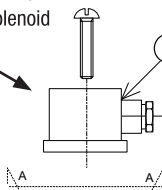

2-core wire within convoluted corrugated sheathing

2

10.8"

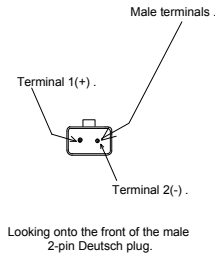
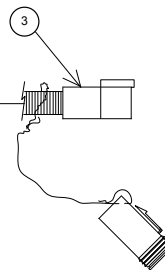

Note:

1. Item no. 1 plug. The two points 1 and 2 are terminated. Terminal 1 is red and is positive(+). Terminal 2 is to be black and is negative(-). Note the orientation of the terminal block
2. Harness manufacturer to affix part no. tag to harness .
3. Harness manufacturer to supply 205910 in a sealed plastic bag showing part number and order number on bag label.

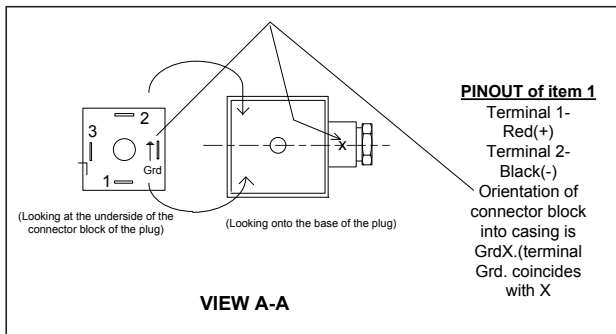

10 TWO SPEED ELECTRICS INSTALLATION

BELOW IS THE LAYOUT DRAWING AND SCHEMATIC DRAWING OF THE SPEED CONTROLLER PART NO. 205911 USED ON 2 SPEED DRIVE UNITS.

205911 - LAYOUT

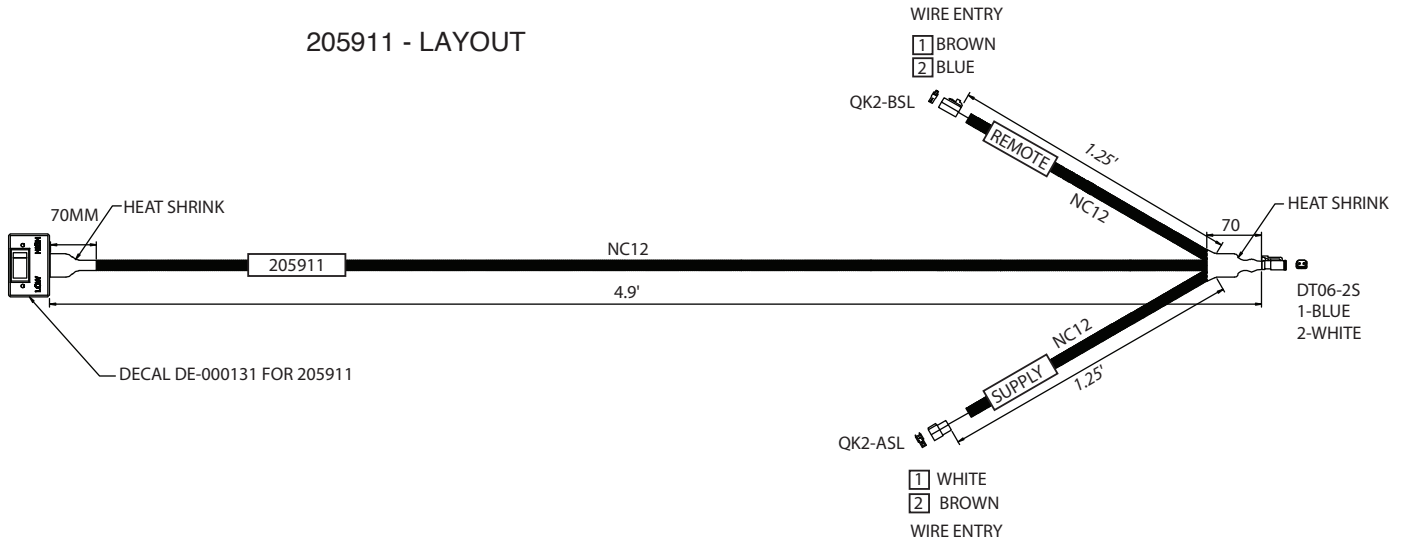

10 TWO SPEED ELECTRICS INSTALLATION

205911 - SCHEMATIC

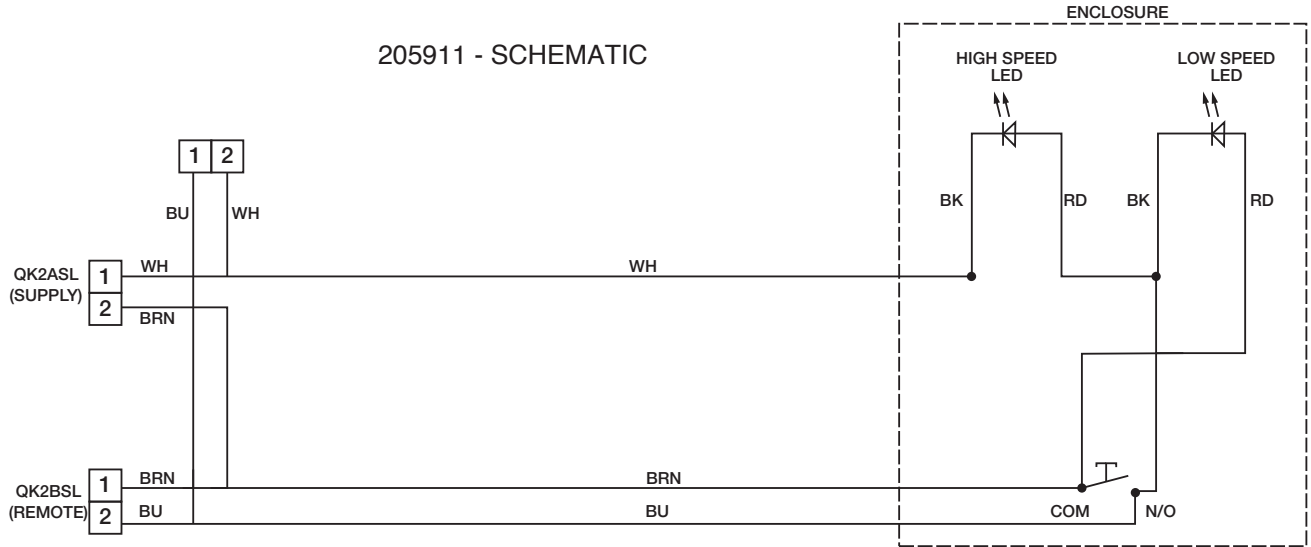

HOW TO OPERATE THE SPEED CONTROLLERS

BLUE DIAMOND® 2-SPEED CONTROLLER (FOR 2-SPEED DRIVE UNIT)

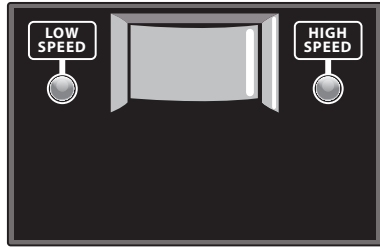

PART NO. 205911

1. The 2-speed controller runs on 2 set speeds, high and low.
2. When power is connected to the 2-pin plug on the controller harness one of the LED's will illuminate dependant on which position the rocker switch is in, thus indicating that there is power getting to the controller.
3. When the rocker switch is set in the low speed position the LED adjacent will illuminate.
4. When the rocker switch is set in the high speed position the LED adjacent will illuminate.
5. The 2 speed switch can also operate with a remote joystick-mounted toggle switch (part no. 205912) or floor mounted remote dip switch (part no. 205913) see page 42.
6. To determine the output shaft rotational speeds when in low speed & high speed refer to the Torque Chart for your drive unit.
7. If using a remote joystick mounted toggle switch part number **205912** or a floor mounted switch part number **205913** to select the two speeds, then the rocker switch on the 2-speed controller, must be positioned in the low speed default position.

11 TWO SPEED OPERATING INSTRUCTIONS

Blue Diamond® Attachments REMOTE SWITCHES (OPTIONAL)

If using a remote oystick mounted toggle switch part number 2 5912 or a floor mounted switch part number 2 5913 to select the two speed, then the rocker switch on the 2 speed controller, must be positioned in the low speed position.

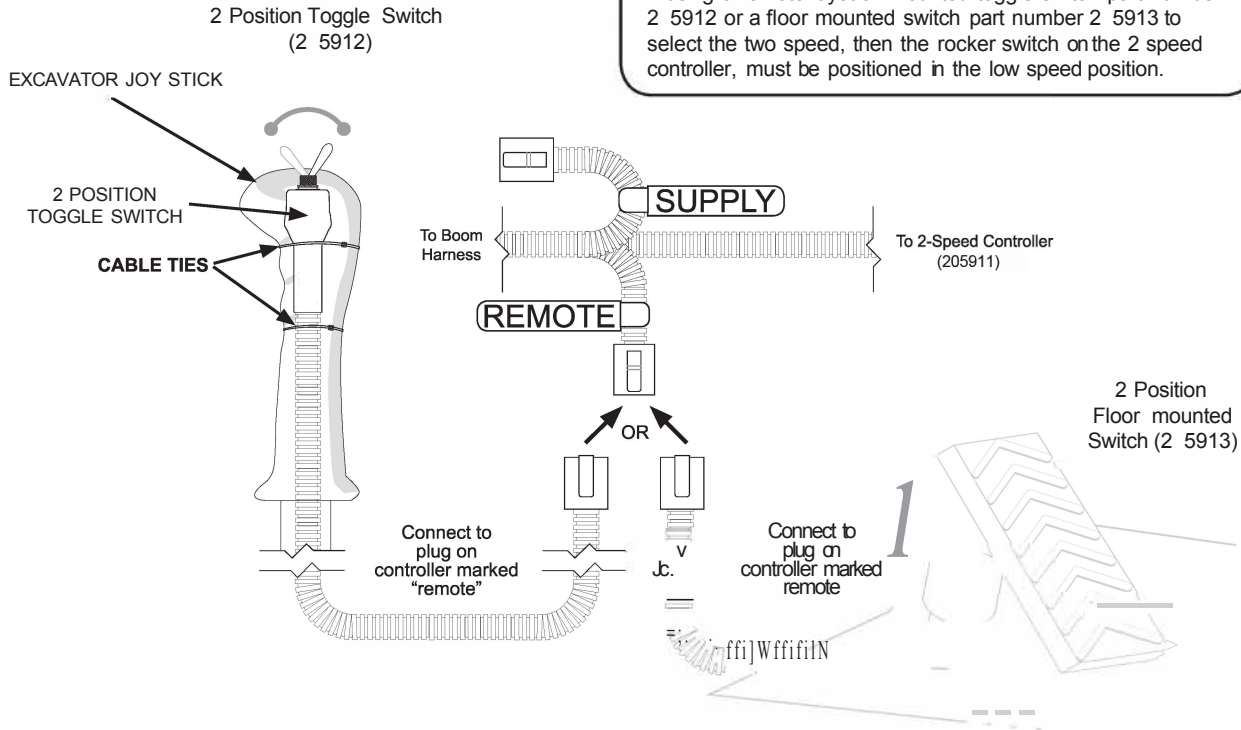



IMPORTANT: OIL CHANGE SCHEDULE

THE GEARBOX OIL CAPACITY IS ENGRAVED ONTO THE SERIAL TAG LOCATED ON THE TOP OF THE HOOD.

Initial (Bed in) oil change:

The first oil change must be carried out within the first 5 hours of use under MODERATE OPERATING CONDITIONS. Thereafter, every 5 hours.

Change the gear oil after the first 3 hours of SEVERE OPERATING CONDITIONS . (i.e. severe ambient temperature conditions of 4 C or below C, when augering, screw piling or core barrelling in hard ground.) Thereafter, every 3 hours.

	MODERATE OPERATING CONDITIONS	SEVERE OPERATING CONDITIONS*
FIRST OIL CHANGE	Within 3 months OR initial 5 hours of use	Within the first 3 hours of use
2ND OIL CHANGE PLUS SUBSEQUENT OIL CHANGES	After 5 hours or 12 months of use	After 3 hours of use thereafter (Drive requires a major stripdown, inspection and rebuild)
GEARBOX OIL: CHEVRON MEROPA ISO 32 MINERAL OIL NORTH AMERICA EX1 TO EX3 /AE3 HF		
* SEVERE OPERATING CONDITIONS: AMBIENT TEMPERATURES BELOW 0° (32 F) ABOVE 4 C (14 F) .WORKING IN HARD GROUND. EXTENDED AND CONTINUOUS HOURS OF OPERATION.		

MINIMUM AND MAXIMUM GEAR OIL OPERATING TEMPERATURE FOR GEARBOXES

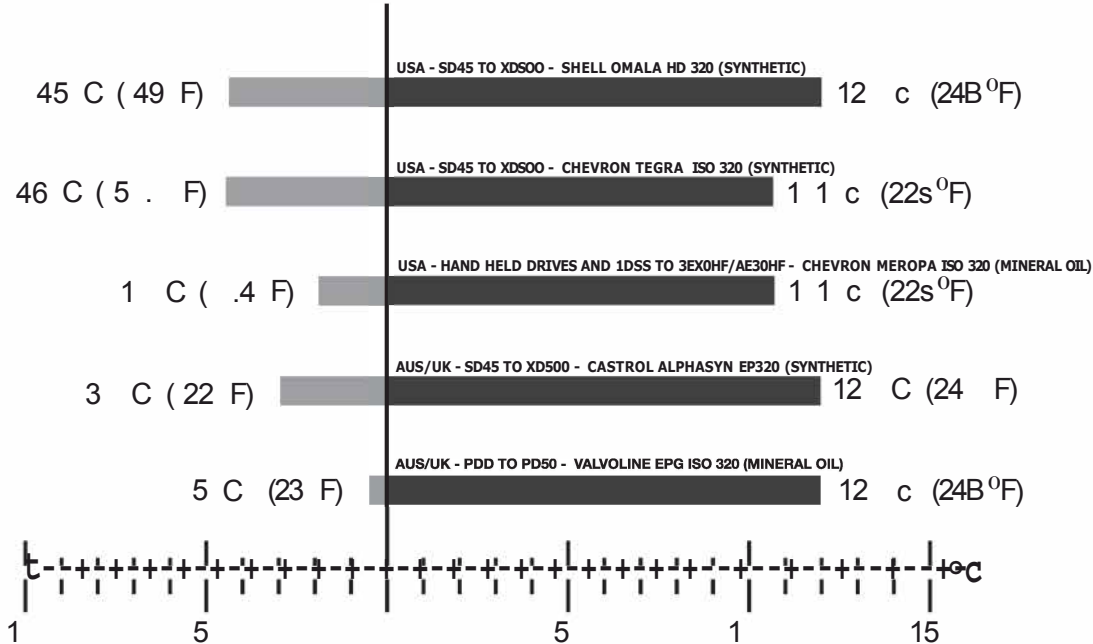

INSTRUCTIONS ON HOW TO WARM UP A DRIVE IF OPERATING BELOW 40° F (5° C) CAN BE FOUND ON PAGE 24. PLEASE READ AND UNDERSTAND THESE INSTRUCTIONS.

PROCEDURE TO CHECK THE GEARBOX OIL LEVEL

Unfortunately, there is no provision to make a quick visual inspection of the gearbox oil level. The gearbox is filled to the correct level at the factory. Unless there are clear signs of gearbox oil leakage it should not require topping up between scheduled oil changes or services.

PROCEDURE TO DRAIN GEAR BOX OIL

The gearbox oil change interval should be carried out in accordance with the requirements set out in the table on page 43. It is advisable to replace the output shaft seal at the first oil change as this is the most important oil change to prolong the life of bearings and gears. The reasoning behind this is that whilst bedding in, gearboxes can generate fine metallic contamination. This will find its way to the lowest part of the gearbox and collect in the output seal thus allowing an abrasive paste to wear the output seal and the output shaft. It is advisable that oil changes are performed by a Blue Diamond Authorized Service Agent, however it is not always possible for many reasons to get this done by a Dealer however what is important is that the oil is changed at the required intervals.

Remember to consider the environment, state and federal laws relating to disposal of oil. Dumping and spillage of oil onto land, storm water outlets and waterways is illegal. Oil must be disposed of by professional waste disposal or recycle specialists.

1. Ensure that the gearbox is stable, secure and safe to work on prior and that the drive unit is vertical and that there is an appropriate sized drip tray to catch the drained oil.
2. Before commencing to drain any oil, check the serial tag of the unit to determine the quantity of oil which the gearbox holds. This will indicate the quantity of oil which has to be replaced into the gearbox and size of bucket needed to contain the oil. Remove the drain plug from the output housing. This will allow the bulk of the gearbox oil to drain out. (this will not drain the gearbox entirely). The lower section of the output housing, below the plug will still contain some oil.
3. To drain the remaining oil, lie the drive unit on its side with the bung hole facing down.
4. Once all oil has been drained follow the procedure on the following page to refill oil.

PROCEDURE FOR CHANGING OR RE FILLING GEARBOX OIL LEVEL

Use correct oil. See page 44.

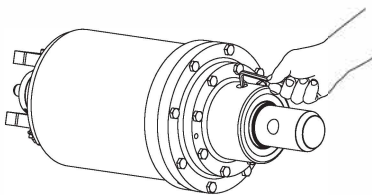

1. Lay the drive unit flat on the ground with the oil fill bung facing up. Using an mm Allen key remove the bung.

To drain oil, turn the drive until the hole is facing down. Allow to drain until all oil has been removed.

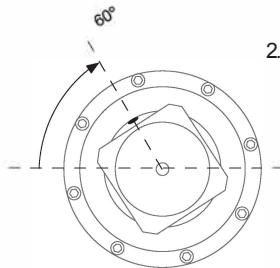

2. Rotate the unit until the oil fill hole is sitting between 6 7 from horizontal

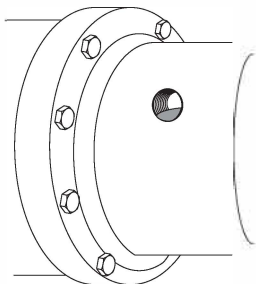

3. Once the filler hole is at appro 6 the oil should be sitting at the base of the filler hole thread

4. If the oil level is too low to reach the thread it should be topped up. Rotate the Unit so the filler hole is sitting at the top and add oil. Repeat steps 2 4 until you have achieved the correct level.

Note that the oil takes time to work its way through the gearbo . Allow time for it to settle once it has reached the bung hole. Then check the level again until all seepage has occurred.



NOTE: IF YOUR UNIT IS LEAKING OIL AFTER YOU HAVE PERFORMED THE DAILY CHECKS CONSULT YOUR LOCAL AUTHORIZED SERVICE AGENT.

TO REPLACE TEETH ON AN AUGER



WARNING: ALWAYS WEAR SAFETY GLASSES WHEN REPLACING TEETH ON AUGERS. RISK OF EYE INJURY FROM FLYING OBJECTS

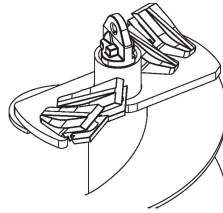

1. Position Auger so that it is easily accessible at the bottom

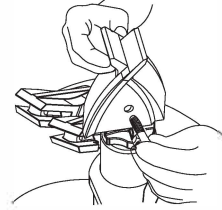

2. Place Pilot on bottom of Auger and secure with nut and bolt.

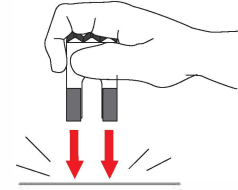

3. Tap Tooth (rubber side down) to ensure rubber is attached firmly.

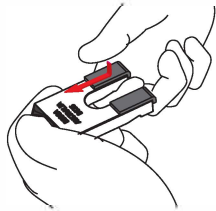

4. Press rubber on the front of the Tooth to ensure felt is attached firmly.

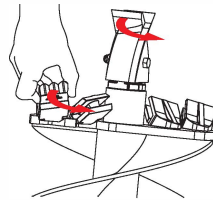

5. Place tooth in the pocket ensuring the tooth cutting edge is facing the same direction as the pilot.



6. With the tooth placed in the pocket, knock the tooth in with a soft head (copper) mallet.

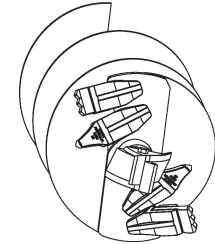

7. Continue until all teeth are replaced as necessary.



WARNING: Do not use steel hammer, tungsten can shatter.

13 AUGERS AND WEAR PARTS

MAINTAIN YOUR AUGER BIT

The Auger is a ground engaging tool fitted with wear parts to dig holes. Therefore, the Auger Teeth & Pilot must be checked regularly and replaced with new wear parts. Failure to do so will cause premature wear and damage to the Auger Pockets and Flighting, and substantially reduce the drilling performance of the auger bit.

Model	Application	Length	Max diameter
HD	Sand & Dirt	48"	36"
HD w/ Cast Head	Rocky/Frozen dirt	48"	48"
Rock Bit	Solid rock	48"	36"
Tree bit	Installing tree bulbs	48"	48"

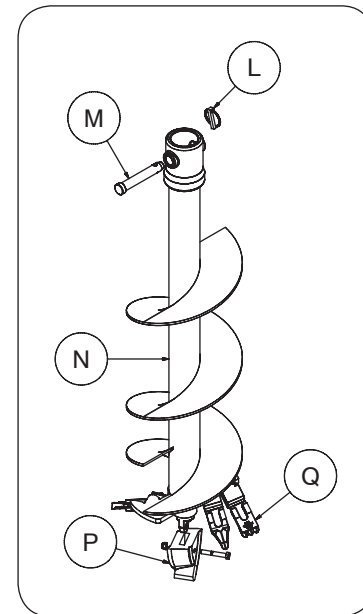

REF	DESCRIPTION	QTY
L	NUT	1
M	BOLT	1
N	AUGER	1
P	WEAR PART - PILOT	1
Q	WEAR PART - PADLOC TEETH	*

IMPORTANT:

CHECK THE WEAR PARTS ON YOUR AUGER ON A REGULAR BASIS. ENSURE ALL REPLACEMENT PARTS ARE GENUINE DIGGA WEAR PARTS

For spare parts for your planetary drive unit, obtain the serial number off the aluminum serial tag located between the hood ears on the top of the hood of the drive unit. The serial number allows BDA to trace all production and service records.

Ensure all service and maintenance is performed by an authorized BDA service agent and all service records are kept.

Below is a list of electrical switches, speed controllers and harnesses which are available on all 2 speed planetary drive units.

For all other spare parts contact your nearest BDA dealer.

2 SPEED

DESCRIPTION	PART NUMBER
Blue Diamond 2 speed motor harness	205910
Blue Diamond 2 speed controller 12v/24 (optional)	205911
Blue Diamond Remote 2 position toggle switch (optional) Blue	205912
Diamond floor mounted remote 2 position switch (optional) 2	205913
Speed 3m Extension Harness (optional)	200013
2 Speed 6m Extension Harness (optional)	200012
2 Speed 12m Extension Harness (optional)	200014
2 Speed 15m Extension Harness (optional)	200016
Power Lead (optional)	205914
2 Pin to 8- Pin Adaptor CAT/ASV/TEREXX	216905
2 Pin to 14 Pin Adapter Kit	216902
2 Pin to 14 Pin Adapter Harness	216900

SINGLE AND TWO SPEED DRIVE UNIT

TROUBLE	POSSIBLE CAUSE	REMEDY
No Rotation	Quick disconnect fitting(s) not engaged	Check quick disconnect fitting(s)
	Quick disconnect fitting(s) faulty	Replace faulty fitting(s)
	Auxiliary valve on machine faulty	Refer to machine manual
	Hydraulic oil tank low	Fill oil tank to maximum level
	Hydraulic motor failure	Contact your BDA Dealer*
	Output shaft bearing failure	Contact your BDA Dealer*
	Planetary gear failure	Contact your BDA Dealer*
Slow Rotation	Machine oil pump faulty	Refer to machine manual
	Low oil flow	Check machine specifications
	Drive unit to large for machine	Contact your BDA Dealer*
Hood Leaking Oil	Hydraulic system too hot	See hydraulic section
	Hose(s) or Fitting(s) Leaking	Tighten or replace
Output Shaft Leaking Oil	Motor 'O' ring failure	Contact your BDA Dealer*
	Oil seal failure	Contact your BDA Dealer*
No Torque	Hydraulic motor failure	Contact your BDA Dealer*
	Oil pressure too low	Check machines specifications
	Drive unit too small for machine	Contact your BDA Dealer*
Grinding or Loud Noise	Hydraulic system too hot	See hydraulic section
	Gearbox failure	Contact your BDA Dealer*

2-SPEED DRIVE UNIT

TROUBLE	POSSIBLE CAUSE	REMEDY
The 2-speed is only operating in low speed	No Power supplied to the controller	Ensure that the correct voltage is supplied to the controller. The one LED light will illuminate. NOTE: The 2-speed drive units can be supplied from BDA in either a 12 volt or 24 volt setup at the factory specific for the excavator which the drive unit is to be used on. Check that the green LED light is illuminated on the cigarette lighter plug of the power lead.
	Controller not connected to the extension harness	Check Extension cables and harnesses to ensure they are plugged in and secure.
	Extension harness not plugged into the motor harness	Check Extension cables and harnesses to ensure they are plugged in and secure.
	Excavator is 24v and Drive unit has been setup for a 12v supply	This may have burnt out the solenoid coil. Contact your BDA Dealer*

***DO NOT DISASSEMBLE DRIVE TO ASSES FAULT. DISASSEMBLY WITHOUT WRITTEN PERMISSION AND INSTRUCTIONS FROM BLUE DIAMOND® WILL VOID ALL WARRANTY.**

HYDRAULIC SYSTEM

TROUBLE	POSSIBLE CAUSE	REMEDY
Oil Over Heating	Oil Pressure too Low	Set Relief Valve to Machine Spec
	Restriction in Line	Inspect and Repair
	Auger Continually Stalling	Limit Down Pressure
	Drive Unit too Small	Contact your BDA Dealer*
	Machine too Small	Fit Drive Unit to Larger Machine
	Hydraulic Oil Tank Low	Fill Oil Tank to Maximum Level
	Insufficient Oil Capacity	Fit Oil Cooler

AUGERS

TROUBLE	POSSIBLE CAUSE	REMEDY
Slow Digging Speed	Worn Teeth or Pilot	Replace (See Wear parts, inside back cover)
	Ground too Hard	Contact your BDA Dealer*
	Low Oil Flow	Check Machine Specifications
	Auger too Large for Drive Unit	Fit Larger Drive Unit
	Machine too Small	Fit Drive Unit to Larger Machine

Blue Diamond® Attachments

4512 Anderson Rd.
Knoxville, TN 3791

PH: 888-376-702

WEB: bluediamondattachments.com

EMAIL: info@bdattachments.com

WARRANTY STATEMENT

EX & EXHF Drive Units ; - Used for Drilling Application
Motor - Warranty up to 3 years subject to manufacturers inspection
Gearbox - Warranty up to 5 years subject to manufacturers inspection

AEX & AEXLP Drive Units- Used for Anchor Application AD/L5 – AD/L30 fitted with ECV (Swoosh)
Motor - Warranty up to 2 years subject to manufacturers inspection
Gearbox - Warranty up to 3 years subject to manufacturers inspection

EX, EXHF & EXLP Drive Units - Used for Anchoring Application up to 12,000ft lbs WITHOUT ECV (Swoosh)
Motor - Warranty up to 1 years subject to manufacturers inspection
Gearbox - Warranty up to 2 years subject to manufacturers inspection

EXHF & EXLP Drive Units - Used for Anchoring Application over 12,000ft lbs not fitted with ECV (Swoosh)
No warranty

All new Blue Diamond® products are warranted to be free from defects in materials or workmanship, for a period of twelve (12) months from date of original purchase, which may cause failure under normal usage and service when used for the purpose intended. In the event of failure (excluding cable, ground engaging parts such as sprockets, digging chain, bearings, teeth, tamping and demolition heads, blade cutting edges, pilot bits, auger teeth, auger heads), if after examination, Blue Diamond® determines failure was due to defective material and/or workmanship, parts only will be repaired or replaced. Blue Diamond® may request defective product or products be returned prepaid to them for inspection at their place of business or to a location specified by Blue Diamond®. The warranty will be considered void if the product or any part of the product is modified or repaired in any way not expressly authorized by Blue Diamond®, or if closed components are disassembled prior to return. Closed components include, but are not limited to: Gearboxes, Hydraulic pumps, Motors, Cylinders and Actuators. Any goods returned to Blue Diamond® by the customer under warranty must have all freight charges prepaid for on the customers account. Any claims under this warranty must be made in fifteen (15) days after Buyer learns of the facts upon which such claim is based. All claims not made in writing and received by Blue Diamond® outside the time period specified above shall be deemed waived.

DAMAGE OR FAILURE THROUGH OPERATOR ABUSE OR NEGLIGENCE VOIDS WARRANTY.

This warranty is in lieu of all other warranties expressed or implied and there are no warranties of merchantability or of fitness for a particular purpose. In no event shall Blue Diamond® be liable for consequential or special damage. Blue Diamond®'s liability for any and all losses and damages to buyer, resulting from any cause whatsoever, including Blue Diamond®'s negligence, irrespective of whether such defects are discoverable or latent, shall in no event exceed the purchase price of the particular products with respect to which losses or damages are claimed, or at the election of Blue Diamond®, the repair or replacement of defective or damaged products.

