

12' Flex Wing Brush Cutter

Operation and Maintenance Manual



403150 – REVISION 000001

Register your
WARRANTY
within 30 days
of purchase



888-376-7027 | BlueDiamondAttachments.com



BD-092

Introduction: Owner Information

Thank you for your decision to purchase a Blue Diamond® 12' Flex Wing Brush Cutter. To ensure maximum performance of your equipment, it is mandatory that you thoroughly study the Operator's manual and follow the recommendations. Proper operation and maintenance are essential to maximize equipment life and prevent personal injury.

Operate and maintain this equipment in a safe manner and in accordance with all applicable local, state, and federal codes, regulations and /or laws. Follow all on-product labeling and instructions.

Make sure that all personnel have read this Operator's Manual and thoroughly understand safe and correct operating, installation and maintenance procedures.

Blue Diamond is continually working to improve its products. Blue Diamond reserves the right to make any improvements or changes as deemed practical and possible without incurring any responsibility or obligation to make any changes or additions to equipment sold previously.

Although great care has been taken to ensure the accuracy of this publication, Blue Diamond makes no warranty or guarantee of any kind, written or expressed, implied or otherwise with regard to the information contained within this manual. Blue Diamond assumes no responsibility for any errors that may appear in this manual and shall not be liable under any circumstances for incidental, consequential or punitive damages in connection with, or arising from the use of this manual.

Keep this manual available for frequent reference. All new operators or owners must review the manual before using the equipment and annually thereafter. Contact your Blue Diamond Attachments Dealer for assistance, information, or additional copies of the manual. Contact www.bluediamondattachments.com or call 888-376-7027 for a complete list of dealers in your area.

Serial Number Location:

Please record attachment information in the space provided for future reference.



Model Number: _____

Serial Number: _____

Dealer Name: _____

Dealer Number: _____

Date of Purchase: _____

The serial number plate is located on the rear of the center deck.

Always use your serial number when requesting information or when ordering parts.

NOTE: The directions left, right, front and rear, as mentioned throughout this manual, are as viewed from the operator's position and facing in the direction of travel.

Revision Date: 09.19.2023

Blue Diamond® Attachments

Table of Contents

1. Introduction.....	4-6	7. Service and Maintenance.....	33-43
1.1 Attachment Identification.....	4	7.1 Maintenance Safety.....	33
1.2 About this Attachment.....	5	7.2 Welding Safety.....	34
1.2 About this Manual.....	5	7.3 Lubrication.....	35
2. Safety.....	7-11	7.4 Blade Maintenance.....	36
2.1 General Safety Information.....	7	7.5 Blade Carrier.....	38
2.2 Training.....	10	7.6 Slip Clutch Maintenance.....	38
2.3 Safety Decal Instructions.....	10	7.7 Bolt Torque Requirements.....	40
2.4 OSHA Training Requirements.....	10	7.8 Service Record.....	41
3. Assembly.....	12-18	7.9 Troubleshooting.....	42
3.1 Tools Required.....	12	8. Parts.....	44-64
3.2 Assembly Procedure.....	12	8.1 A-Frame Components.....	44
3.3 Leveling the Center Deck.....	13	8.2 Center Deck Components.....	46
3.4 Leveling the Wing Decks.....	14	8.3 Center Shield Components.....	48
3.5 Installing the Driveline.....	16	8.4 Driveline & Shield Components.....	49
3.6 Checking the Driveline Length.....	17	8.5 Wing Deck Components.....	50
3.7 Shortening the Driveline.....	17	8.6 Wheel Lift Components.....	52
4. Operation.....	19-29	8.7 Wheel Options.....	53
4.1 User Safety Training.....	19	8.8 Hydraulic Components.....	54
4.2 Tractor Requirements.....	20	8.9 Chain Guards Components.....	55
4.3 Attaching to the Tractor.....	21	8.10 Driveline & Shield Components.....	56
4.4 Setting the Rotary Cutter.....	23	8.11 Center Deck Driveline Components.....	58
4.5 Inspection Checklist.....	24	8.12 C.V. Drive Components.....	59
4.6 Machine Break-In.....	25	8.13 Wing Driveline Components.....	60
4.7 Pre-Operation Checklist.....	25	8.14 Safety Decal Locations.....	61
4.8 General Operating Procedure.....	26	9. Specifications.....	63
4.9 Chain Shielding.....	27	9.2 Attachment Specifications.....	63
4.10 Right of Way (Roadway) Mowing.....	28	9.1 Torque Specifications.....	64
4.11 Detaching from Tractor.....	28	10. Warranty.....	65
5. Transporting.....	30-31		
5.1 Transport.....	30		
5.2 Transporting Procedure.....	31		
6. Storage.....	32		
6.1 Storage Safety.....	32		
6.2 Placing in Storage.....	32		
6.3 Removing from Storage.....	32		

1. Introduction

1.1 Attachment Identification

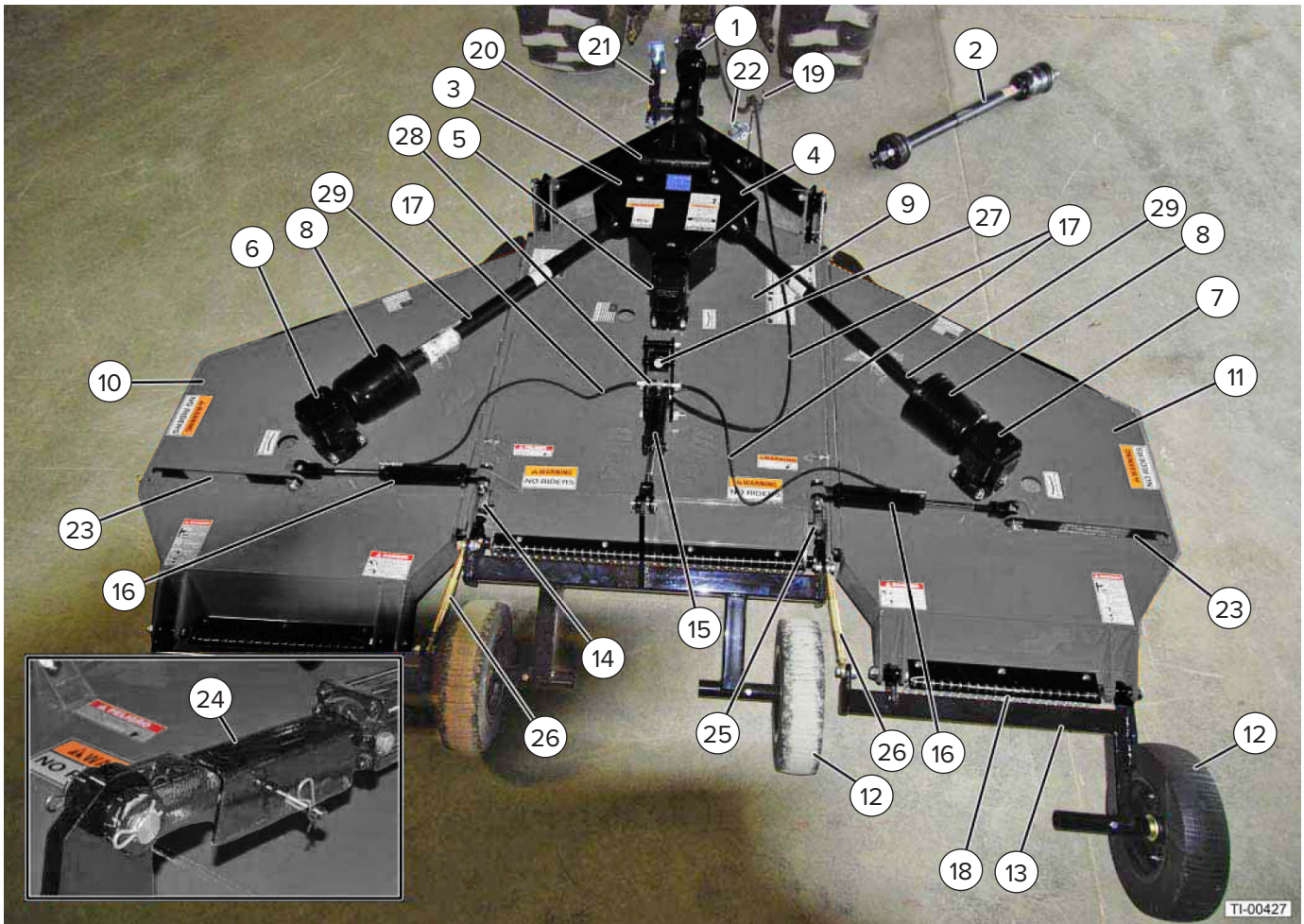

ITEM	DESCRIPTION
1	Swivel Hitch
2	Center Driveline
3	Splitter Gearbox
4	Splitter Gearbox Shield
5	Center Outboard Gearbox
6	Left Outboard Gearbox
7	Right Outboard Gearbox
8	Outboard Gearbox Shield
9	Center Deck
10	Left Wing Deck
11	Right Wing Deck
12	Tailwheel
13	Tailwheel Tube
14	Leveling Rods

15	Lift Hydraulic Cylinder
16	Wing Fold Hydraulic Cylinder
17	Hydraulic Hoses
18	Chain Shielding
19	Hydraulic Hose Holder
20	Document Storage Tube
21	Jack
22	Safety Chain
23	Wing Fold Lock Bar
24	Lift Cylinder Transport Lock
25	Leveling Rod Adjuster
26	Wing Leveling Turnbuckle
27	Suspension Spring Assembly
28	Hydraulic Tee
29	Wing Driveline

1. Introduction

1.2 About this Attachment

Congratulations on your choice of a Blue Diamond® 12' Flex Wing Brush Cutter. This equipment has been designed and manufactured to meet the needs of discerning users.

Many features incorporated into this rotary brush cutter are the result of suggestions made by customers like you. Read this manual carefully to learn how to operate the rotary cutter safely and how to set it to provide maximum cutting efficiency.

By following the operating instructions, in conjunction with a good maintenance program, your Blue Diamond® cutter will provide many years of trouble-free service.

Description and Intended Use

The rotary cutter is designed for cutting weeds, grass, and brush up to 2" in diameter. The cutter uses three spindles with two free-swinging blades each which reduce the shock of impact when a stationary object is contacted. Slip clutches protect the gearboxes and driveline from damage. Standard equipment includes driveline shields, gearbox shields, and front and rear chain discharge shields.



DO NOT use this rotary cutter for any other purpose than its intended use of cutting grass, weeds, and brush.

1.3 About this Manual

Safe Operation

Safe, efficient, and trouble-free operation of your rotary cutter requires that you, and anyone else who will be using or maintaining the unit, read and understand all the information contained in this manual.

Use this manual for frequent reference and to pass on to new operators or owners.



DANGER



READ AND UNDERSTAND THE MANUAL

To prevent personal injury or even death, be sure you and all operators read and understand all of the instructions in this manual and other related OEM equipment manuals! The rotary cutter, if not used and maintained properly, can be dangerous to users unfamiliar with its operation. Do not allow operating, maintaining, adjusting, or cleaning of this rotary cutter until the user has read this manual and has developed a thorough understanding of the safety precautions and functions of the unit.

This rotary cutter is designed for the specific purpose of cutting grass, weeds, and brush. **DO NOT** modify or use this rotary cutter for any application other than that for which it was designed.

Rotary cutters maintained or operated improperly or by untrained personnel can be dangerous exposing the user and/or bystanders to possible serious injury or death.

1. Introduction

1.3 About this Manual Cont'd

Safety Shields

Some of the illustrations in this manual may show the equipment with safety shields removed for clarity. Never operate the rotary cutter unless all safety shields are in place.



WARNING



CUTTING OR ENTANGLEMENT HAZARD

Operating the rotary cutter without the safety shields could result in physical injury or death. Make sure all shields are properly installed before operating the rotary cutter. This equipment should never be operated with any safety shielding removed.

Owner/Operator Manual Storage

Store the Owner/Operator manual and other operating materials in the document storage tube located on the splitter gearbox shield shown in Figure 1.

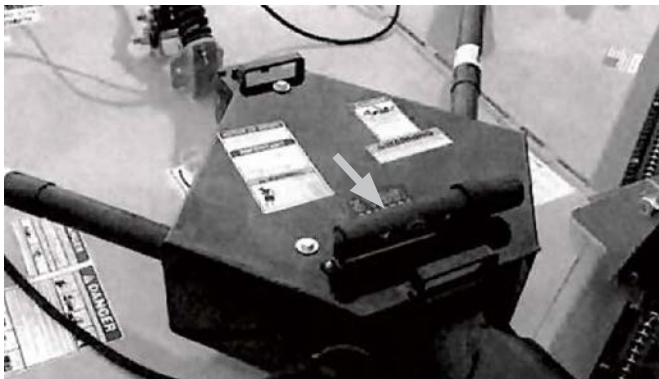

Disposal of Equipment at End of Useful Life

This cutter has been designed for the specific purpose of cutting grass, weeds, and brush. When this unit is no longer capable of doing its designed purpose, it should be dismantled and scrapped. Do not use any materials or components from this unit for any other purpose.

Unanswered Questions

If you have any questions not answered in this manual, require additional copies, or the manual is damaged, please contact your dealer or Blue Diamond® Product Support.

2. Safety

2.1 General Safety Information



This **SAFETY ALERT SYMBOL** identifies important safety messages on the equipment and in the owner's manual. When you see this symbol, be alert to the possibility of personal injury and carefully read the message that follows.



The signal word **IMPORTANT** identifies procedures which must be followed to avoid damage to the machine.



The signal word **DANGER** on the machine and in the manuals indicates a hazardous situation which, if not avoided, will result in death or serious injury.



The signal word **WARNING** on the machine and in the manuals indicates a potentially hazardous situation which, if not avoided, could result in death or serious injury.



The signal word **CAUTION** on the machine and in the manuals indicates a potentially hazardous situation which, if not avoided, may result in minor or moderate injury. It may also be used to alert against unsafe practices.

NOTE: Notes are used to indicate important information. This information may be repeated in other areas of the manual.

General Safety

Safety of the operator and bystanders is one of the main concerns in designing and developing a new piece of equipment. Designers and manufacturers build in as many safety features as possible. However, every year many accidents occur which could have been avoided by a few seconds of thought and a more careful approach to handling the equipment.

Most work-related accidents are caused by failure to observe basic safety rules or precautions. An accident can be avoided by recognizing potentially hazardous situations before an accident occurs. As you assemble, operate, or maintain the rotary cutter (unit), you must be alert to potential hazards. You should also have the necessary training, skills, and tools to perform any assembly or maintenance procedures.

Improper operation and maintenance of this unit could result in a dangerous situation that could cause injury or death.

If you have any questions not answered in this manual or require additional copies or the manual is damaged, please contact your dealer or Blue Diamond® Product Support.



DO NOT assemble, operate, or maintain the unit until you read and understand the information contained in this manual.

Safety precautions and warnings are provided in this manual and on the unit. If these hazard warnings are not heeded, bodily injury or death could occur to you or to other persons.

Blue Diamond® cannot anticipate every possible circumstance that might involve a potential hazard. The warnings in this manual and on the unit are, therefore, not all-inclusive. Blue Diamond® is not responsible for any injury resulting from the use of this attachment. You as the operator have sole responsibility for keeping and maintaining the safety as it relates to this attachment and any other equipment you use or allow to be used.

2. Safety

2.1 General Safety Information

Operating Safety



The owner/operator is responsible for the SAFE use and maintenance of the rotary cutter. Make sure anyone who is operating, maintaining, or working around the rotary cutter is familiar with the operating and maintenance procedures and related SAFETY information contained in this manual. This manual will take you step-by-step through your working day and alerts you to all good safety practices that should be used while using the rotary cutter.

In addition to the design features of the rotary cutter, including safety signs, accident prevention is dependent upon the awareness, concern, prudence, and proper training of the people involved in the operation, maintenance, and storage of the rotary cutter.

These general safety instructions apply to the overall use and maintenance of the rotary cutter.

In addition to this safety section, refer also to safety messages and instructions in each of the appropriate sections of this manual.



More specific instructions on safety are found in the operation, transporting, maintenance, and storage sections of this manual. Refer to these sections before performing any of these tasks.

 **DANGER** 

Failure to comply with the following safety instructions will result in death or serious injury.

- **Crush Hazard.** Driveline separation or PTO stub shaft failure can cause serious injury or death. Make sure drivelines and driveline shields are the correct length and correctly installed.
- **Entanglement Hazard.** Failure to maintain shields and deflectors may result in serious injury or death from entanglement.

- **Crush Hazard.** Hydraulic or mechanical failure can allow a wing to drop suddenly without warning. DO NOT allow anyone to walk under or stand near a raised wing.

 **WARNING** 

Failure to comply with the following safety instructions could result in serious injury and possibly even death if they are not understood and followed.

- **Provide User with Literature.** The owner/operator must provide any operator instructions to anyone using the rotary cutter before use, and at least annually thereafter. Refer to Section 2.4 OSHA Training Requirements on page 10.
- **Stay Clear.** Clear the area of people, especially small children, before using the rotary cutter. Under no circumstances should young children be allowed to work with or around the rotary cutter.
- **Impaired User Hazard.** Do not attempt to assemble, operate, or maintain this rotary cutter under the influence of drugs or alcohol. Consult your doctor before using this rotary cutter while taking prescription medications.
- **Crush Hazard.** Do not allow anyone to ride on the tractor or the rotary cutter. Falling or crushing hazards could result in severe injuries or death.
- **Falling Hazard.** Do not allow riders on the hitch, tractor, or rotary cutter at any time. Falling could result in severe injuries or death.
- **No Unauthorized Modifications.** DO NOT modify the rotary cutter or safety devices. DO NOT weld on the unit. Unauthorized modifications may impair its function and safety. Personal injury or death could result from unauthorized modifications. If the rotary cutter has been altered in any way from the original design, Blue Diamond does not accept any liability for injury or warranty.

2. Safety

2.1 General Safety Information Cont'd

Operating Safety Cont'd

- **Damaged Parts Hazard.** DO NOT use the rotary cutter if any parts are damaged. If the rotary cutter has a defect, immediately stop using it and remedy the problem before continuing.
- **Thrown Objects Hazard.** Rotary cutter can throw objects up to 300 feet. To avoid serious injury or death:
 - *Keep all thrown object shielding in place.*
 - *Inspect area for potential thrown objects before cutting*
 - *Do not operate the rotary cutter with the deck or wings raised*
- **Improper Use Hazard.** DO NOT use cutter to lift or carry objects, tow other equipment, pull fence posts, stumps, or other objects, or for any other purpose than its intended use of cutting grass, weeds, and brush. Using the cutter for unintended purposes can cause serious bodily injury or death.



CAUTION



The following safety instructions are provided to help prevent potential injury. Not following these instructions may lead to injury.

- **Personal Protective Equipment.** When using this rotary cutter, wear appropriate personal protective equipment. This list may include, but is not limited to:
 - *Protective shoes with slip resistant soles*
 - *Protective goggles, glasses, or face shield*
 - *Protective clothing and gloves*
 - *Safety vest (when operating near roads)*
 - *Hearing protection*

- **Hearing Loss.** Prolonged exposure to loud noise may cause permanent hearing loss! Working environments with noise-producing equipment can cause partial to permanent hearing loss. We recommend using hearing protection any time noise levels exceed 80 decibels (dB). Noise levels over 85 dB, on a long-term basis, can cause severe hearing loss. Noise levels over 90 dB over a period of time can cause permanent and even total hearing loss.
Hearing loss from loud noise is cumulative over a lifetime without hope of natural recovery.
- **Crush Hazard.** The tractor should be equipped with a Roll Over Protective Structure (ROPS) and a seat belt. A crushing hazard may occur if the driver is ejected from the seat while the tractor is in motion. Fasten the seat belt whenever the tractor is moving.



IMPORTANT



SAFETY ALERT SYMBOL



The following safety instructions are provided to help prevent injury or limit equipment damage.

- **Safety Signs.** Replace any missing or hard-to-read safety signs or instructional labels. Use care when washing or cleaning the rotary cutter.
Replacement safety sign locations and part numbers are provided in this manual in section 8.15 Safety Decal Locations on page 63. This information is also available from your authorized Blue Diamond® dealer or Blue Diamond® Product Support.
- **First Aid Kit.** Have a first aid kit available for use should the need arise and know how to use it.
- **Fire Extinguisher.** Have a fire extinguisher available for use should the need arise and know how to use it.

2. Safety

2.2 Training

Anyone who will be using and/or maintaining the rotary cutter must read, clearly understand, and follow ALL safety, operation, other related OEM manuals, and the safety signs.

If you do not understand any information in this manual, see your dealer or contact Blue Diamond® before proceeding.

Do not use or allow anyone else to use this rotary cutter until all information has been reviewed. Annually review this manual before the season start-up.

Make periodic reviews of SAFETY and OPERATION of the rotary cutter a standard practice. An untrained operator is not qualified use this rotary cutter.

2.3 Safety Decal Instructions

The types of safety signs (hazard labels) and instructional labels, along with their locations on the equipment, are shown in the following illustrations. Good safety practices require that you familiarize yourself with the various safety signs, the type of warning, and the area or particular operation related to that area that requires your SAFETY AWARENESS.

Pay close attention to the safety signs and instructional labels attached to the tractor and the rotary cutter. Duplicate safety signs, which are attached to the rotary cutter, can also be found in this section. If the rotary cutter is missing a label or one is unreadable, replace the label before using the rotary cutter.



The following safety instructions are provided to help prevent injury.

- Keep safety signs or instructional labels clean and legible at all times. Use a clean, damp cloth to clean safety decals.
- Replace any missing or hard-to-read safety signs or instructional labels.

- Use care when washing or cleaning the equipment not to remove or damage the labels. When using a pressure washer to clean the rotary cutter, avoid spraying too close to decals; high-pressure water can enter through very small scratches or under edges of decals causing them to peel or come off.
- Locations for the labels and replacement part numbers are shown in this section.
- Replacement parts must have replacement labels attached during installation and/or before the rotary cutter is used.
- Labels are available from your authorized dealer or from Blue Diamond® at no charge.

How to Install Replacement Safety Signs

1. Clean and dry the installation area.

NOTE: Do not install the signs if the temperature is below 50°F.

2. Determine the exact position before you remove the backing paper.
3. Remove the backing paper.
4. Align the sign over the specified area and carefully press the sign to the part/frame.

NOTE: Small air pockets can be pierced with a pin and smoothed out using the piece of backing paper.

See section 10.15 Safety Decal Locations on page 63 for safety decal locations.

2.4 OSHA Training Requirements

The following training requirements have been taken from Title 29, Code of Federal Regulations Part 1928.57 (a)(6). www.osha.gov.

Operator Instructions

At the time of initial assignment and at least annually thereafter, the employer shall instruct every employee who operates an agricultural tractor and implements in the safe operating practices and servicing of equipment with which they are or will be involved, and of any other practices dictated by the work environment.

2. Safety

IMPORTANT FEDERAL LAWS AND REGULATIONS CONCERNING EMPLOYERS, EMPLOYEES AND OPERATORS

This section is intended to explain in broad terms the concept and effect of the following federal laws and regulations. It is not intended as a legal interpretation of the laws and should not be considered as such.

U.S. PUBLIC LAW 91-596 (THE WILLIAMS-STEIGER OCCUPATIONAL SAFETY AND HEALTH ACT OF 1970) OSHA

This Act Seeks:

“...to assure so far as possible every working man and woman in the nation safe and healthful working conditions and to preserve our human resources...”

DUTIES

Sec. 5(a) Each Employer —

1. shall furnish to each of its employees employment and a place of employment which are free from recognized hazards that are causing or are likely to cause death or serious physical harm to its employees.
2. shall comply with occupational safety and health standards promulgated under this Act.
(b) Each employee shall comply with occupational safety and health standards and all rules, regulations, and orders issued pursuant to this Act which are applicable to his or her own actions and conduct.

OSHA Regulations

Current OSHA regulations state in part: “At the time of initial assignment and at least annually thereafter, the employer shall instruct every employee in the safe operation and servicing of all equipment with which the employee is, or will be involved in.” These will include (but are not limited to) instructions to:

Keep all guards in place when the machine is in operation;

Permit no riders on equipment;

Stop engine, disconnect the power source, and wait for all machine movement to stop before servicing, adjusting, cleaning, or unclogging the equipment, except where the machine must be running to be properly serviced or maintained, in which case the employer shall instruct employees as to all steps and procedures which are necessary to safely service or maintain equipment.

Make sure no one is within 300 feet of machinery before starting the engine, engaging power, or operating the machine.

EMPLOYEE TRACTOR OPERATING INSTRUCTIONS

1. Securely fasten your seat belt if the tractor has a ROPS.
2. Where possible, avoid operating the tractor near ditches, embankments, and holes.
3. Reduce speed when turning, crossing slopes, and on rough, slick, or muddy surfaces.
4. Stay off slopes too steep for safe operation.
5. Watch where you are going, especially at row ends, on roads, and around trees.
6. Do not permit others to ride.
7. Operate the tractor smoothly – no jerky turns, starts, or stops.
8. Hitch only to the drawbar and hitch points recommended by tractor manufacturers.
9. When tractor is stopped, set brakes securely and use park lock if available.

Child Labor Under 16 Years Old

Some regulations specify that no one under the age of 16 may operate power machinery. It is your responsibility to know what these regulations are in your own area or situation. (Refer to U.S. Dept. of Labor, Employment Standard Administration, Wage & Home Division, Child Labor Bulletin #102).

3. Assembly

3.1 Tools Required

Tools Required	
Wrenches	1/2", 5/8", 3/4", 1-1/8", 1-3/8", 1-1/2"
Ratchet with extension and sockets as above	

3.2 Assembly Procedure

1. Cut the wires holding the center driveline to the cutter. Set the driveline aside for now.

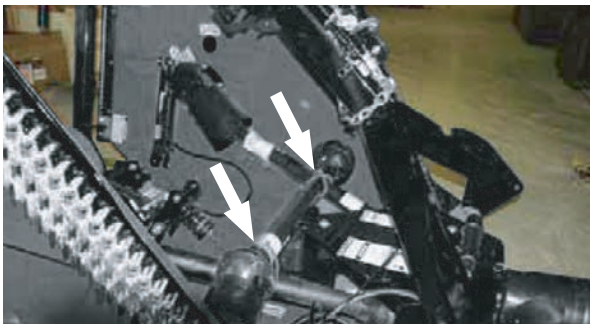

2. Verify that the wing locks and their retaining pins are in place.

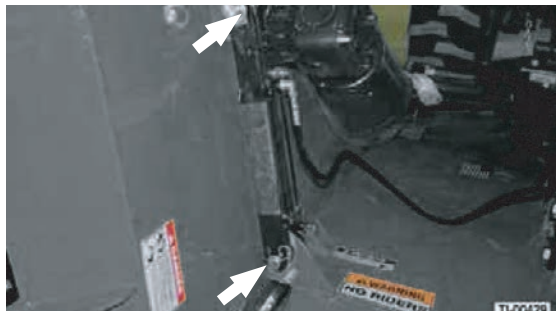

3. Remove the pin, washers, and cotter pins from the front of both leveling rods.

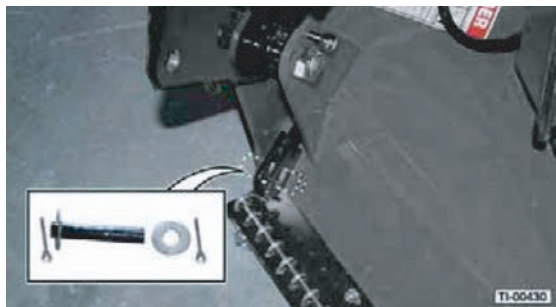

4. Remove and discard the bolts holding the hitch in its shipping position.

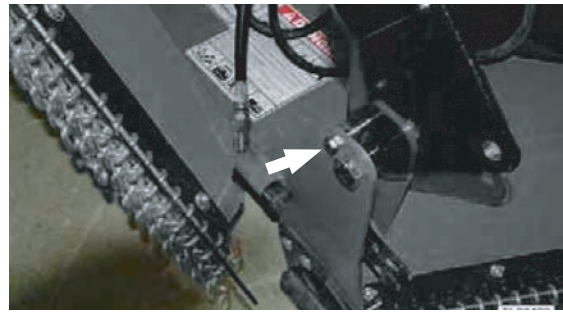

WARNING



CRUSH HAZARD

The weight of the hitch can cause serious injury or death if it falls on a person. Do not allow anyone to walk under or stand near the hitch when it is supported by a lifting device.

5. Rotate the hitch forward using a suitable lifting device. The lifting device may be attached to the safety chain.
6. Remove the jack from its storage location on the left wing and install it on the lug on the left side of the hitch



7. Use the jack to adjust the hitch to the height of the tractor drawbar.
8. Board the tractor and start the engine. Back the tractor up to the cutter hitch until the holes in the drawbar and clevis are aligned.



WARNING



CRUSH HAZARD

Crush hazard between hitch and implement. DO NOT allow anyone to stand between the hitch and implement during hook-up operations.

3. Assembly

3.2 Assembly Procedure Cont'd



WARNING



CRUSH HAZARD

Unexpected separation of the cutter from the tractor can cause death or serious injury. Use only an OEM high strength drawbar pin. Do not use a homemade or shop made pin.

9. Turn off the tractor engine and dismount.
 10. Insert a high strength drawbar pin through the clevis and drawbar holes and install retaining pin. Do not use a homemade or shop made pin.
 11. Route the hydraulic hose through the hose rack and attach to the tractor's hydraulic port.
- NOTE:** Quick disconnect hydraulic couplers are not supplied with the unit. If desired, these may be procured from a local equipment dealer.
12. Board the tractor and start the engine. Place the tractor gear selector in park or set the parking brake.
 13. Cycle the wheel lift cylinder several times to purge any trapped air and charge the hydraulic cylinder.
 14. Raise the cutter fully and remove the transport lock from the lift cylinder.
 15. Lower the cutter to the ground, set the parking brake, shut off the tractor, and remove the key.
 16. Align the hole in the hitch with the hole in the front of the leveling rod, and install the pin, washers, and cotter pins previously removed in Step 3. Repeat for the other leveling rod.



NOTE: If necessary, lengthen the leveling rods by turning the adjustment at the rear of the rods. This will increase the clearance between the leveling rod pin and the hitch pivot bracket.



17. Adjust the leveling rods to have equal amounts of tension. This will be a starting point for a later leveling adjustment.

3.3 Leveling the Center Deck

1. Board the tractor and start the engine. Place the tractor gear selector in park or set the parking brake.



WARNING



CRUSH HAZARD

Crush hazard between hitch and implement. **DO NOT** allow anyone to stand between the hitch and implement during set-up operations.

2. Use the hydraulics to adjust the cutter height until the front of the skid shoes are two to three off the ground.

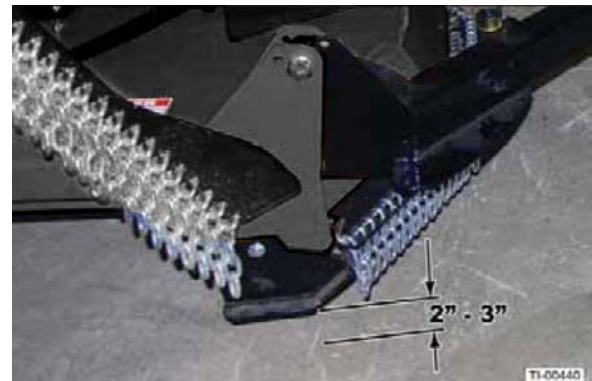

3. Assembly

3.3 Leveling the Center Deck Cont'd



WARNING



CRUSH HAZARD

The weight of the cutter can cause serious injury. Stay clear of the deck when it is raised off the ground.

3. Shorten or lengthen the leveling rods, as needed, until the front of the deck is level with the rear of the deck. Lengthening the leveling rods raise the back of the cutter.



4. Make sure the leveling rods have equal amounts of tension, and tighten the adjuster jam nuts.

3.4 Leveling the Wing Decks

Each wing section will need adjusting if the wing top is not level with the center deck top when the wings are unfolded.

The wing lift hydraulic cylinders are not charged when the cutter is shipped, and must be filled with hydraulic oil before removing the wing locks.

1. Start the tractor and hold the lift control lever in the raised position until the hydraulic cylinders fully retract.
2. Place the control lever in the float position and repeat the process.



WARNING



UNEXPECTED MOVEMENT

The cutter is shipped with the wings locked in the upright position. If the wing locks are not in place, the wings may free-fall due to air in the hydraulic system. To avoid death or serious injury from being struck by a wing, stay clear of the wings. Purge all air from the hydraulic system, and do not remove the wing locks until necessary to do so.

3. Block the wing to prevent it from falling in case air is present in the hydraulic system.



WARNING



CRUSH HAZARD

Hydraulic or mechanical failure can allow a wing to drop suddenly without warning. DO NOT allow anyone to walk under or stand near a raised wing when the locks are removed.

4. Ensure the wings are entirely supported by the cylinders, and there is no tension on the wing lock bars. Remove the wing lock bars from the cylinder pins, rotate them onto the storage lugs, and secure with the retainer hairpins.

3. Assembly

3.4 Leveling the Wing Decks Cont'd

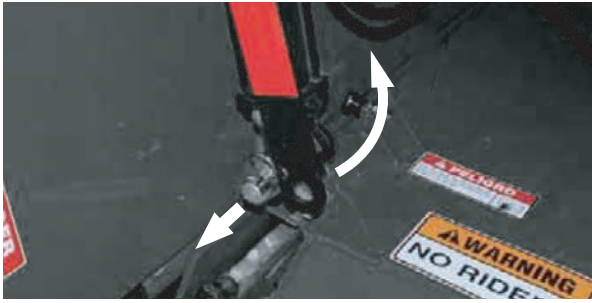

5. Remove the blocking and lower the wings to their operating position.

NOTE: It is normal for the wings to lower or raise at different rates.



6. Check the tractor's hydraulic fluid reservoir.

! IMPORTANT !

The cutter does not have a hydraulic reservoir and therefore can deplete the oil in the tractor's reservoir during initial charging of the cylinders. After this initial setup, with the cutter and wings fully lowered, check the tractor's hydraulic oil reservoir and add oil as necessary.

7. Check the wing tops to see if they are level with the top of the center deck. If the outer edge of either wing top is higher or lower than the center deck, then that wing should be leveled as follows:

a. If the outer wing edge is higher than the center deck, loosen jam nut (Item 1, below) and rotate turnbuckle (Item 2, below) counterclockwise to lower the outer wing edge until the wing is level. Tighten jam nut (Item 1) to the correct torque when level.

b. If the outer wing edge is lower than the center deck, loosen jam nut (Item 1, below) and rotate turnbuckle (Item 2, below) clockwise to raise the outer wing edge until the wing is level. Tighten jam nut (Item 1) to the correct torque when level.

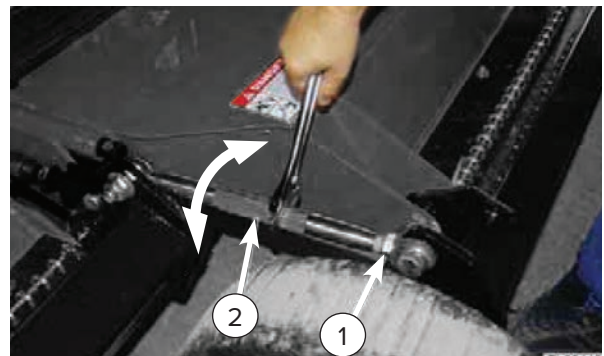

3. Assembly

3.5 Installing the Driveline

1. Remove the two retaining bolts from the front driveline.



2. Install the driveline onto the gearbox input shaft. Insert the retaining bolts in opposite directions from each other, and tighten the locknuts securely.



WARNING



CRUSH HAZARD

If the retaining bolts are not present, the driveline could separate from the gearbox, causing serious injury or death. **DO NOT** omit the retaining bolts. Tighten the locknuts securely.

3. Attach the safety chain on the driveline guard to the gearbox cover.
4. Separate the two halves of the driveline.
5. Apply a bead of grease around the end of the inner drive shaft.



6. Slide the front driveline half over the rear half. Align the square rib on the mating halves to engage.

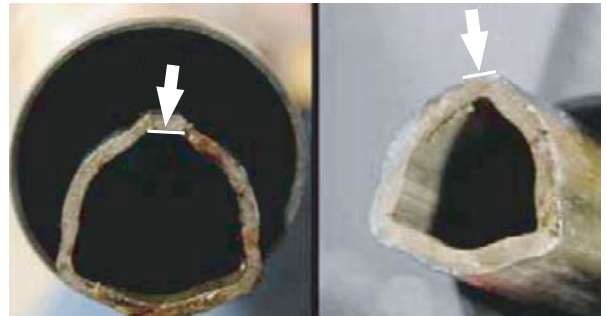

7. Apply grease to the zerks on the U-joint crosses.



3. Assembly

3.6 Checking the Driveline Length

Before operating the rotary cutter, make sure the driveline will not bottom out or become disengaged. Bottoming out occurs when the inner shaft penetrates the outer housing until the assembly can shorten no more. Bottoming out can cause serious damage to the tractor PTO by pushing the driveline into the tractor and through the support bearings or downward onto the PTO shaft, breaking it off. A broken driveline can cause personal injury.

1. Attach the rotary cutter to the tractor following the procedure and observing all warnings in Section 4.3 Attaching to the Tractor on page 21.



WARNING



CRUSH HAZARD

The weight of the cutter can cause serious injury. Stay clear of the deck when it is raised off the ground.

2. Raise and lower the rotary cutter to determine the maximum and minimum distance between the tractor PTO shaft and the gearbox input shaft. If the distance is too large, the driveline will be too short for proper engagement. If the distance is too small, the driveline may bottom out in operation and damage the rotary cutter or tractor.

There must be at least six inches of engagement at the rotary cutter's lowest possible point of operation, and the driveline must not bottom out when raised to the maximum height possible. If the driveline is too short, please call your Blue Diamond dealer for a longer driveline. If the driveline is too long, follow the instructions for shortening the driveline in section 3.7 on page 17.

3.7 Shortening the Driveline

1. Move the rotary cutter up and down to get the shortest possible distance between the tractor PTO shaft and the gearbox input shaft. Shut down the tractor PTO shaft and the gearbox input shaft. Shut down the tractor leaving the rotary cutter in the position of shortest distance. Securely block the rotary cutter in position.
2. Separate the driveline into two halves and connect them to the tractor PTO and gearbox.
3. Place the driveline halves parallel to one another to determine how much to shorten the driveline.
4. Each section should end approximately 3" short of reaching the universal joint shield on the opposite section. If too long, measure 3" back from the universal joint shield and mark on the opposite driveline shield tube.
5. Repeat Step 4 for the other half of the drive.
6. Raise and lower the rotary cutter to determine the position with the greatest distance between the PTO shaft and the gearbox input shaft. Shut down the tractor leaving the rotary cutter in the position of greatest distance. Securely block the rotary cutter in position.
7. Hold the driveline sections parallel to each other and check for minimum 6" overlap. If the driveline has been marked for cutting, the overlap will be the distance between the two marks. If the driveline has less than the minimum overlap, do not use. Contact your Blue Diamond dealer.

NOTE: If the driveline is the correct length, omit the following Steps 8 – 9 and proceed to Step 10.

3. Assembly

3.7 Shortening the Driveline Cont'd

8. Clamp a driveline section in a well-padded vice to prevent damage to the shield. Cut off the shield tube where marked. Using the cut off section of the shield as a guide, cut the shaft the same amount, Repeat for the other driveline section.
9. File and clean the cut ends of both drive halves. Remove all chips and filings.
10. Apply multi-purpose grease around the inner driveline section. Slide the drive halves over each other several times to distribute the grease. Install the driveline on tractor and rotary cutter. Make certain the driveline shielding is in place and in good condition.

NOTE: DO NOT use the rotary cutter if proper driveline engagement cannot be obtained through these methods. Contact your Blue Diamond dealer.

4. Operation

4.1 User Safety Training

Refer to Section 2.1 General Safety Information on page 7 for user safety training requirements.



WARNING



Failure to comply with the following safety instructions could result in serious injury and possibly even death if they are not understood and followed.

- **Roll Away Hazard.** Before leaving the tractor seat, make sure the engine is stopped, the transmission is placed in park, the key is removed, and the parking brake is set. The weight of the tractor, plus the rotary cutter if it rolls onto a person, could cause serious crushing injury or death.
- **Crush Hazard.** The tractor should be equipped with a Roll Over Protective Structure (ROPS) and a seat belt. A crushing hazard could occur if the driver is ejected from the seat while the tractor is in motion. Fasten the seat belt whenever the tractor is moving. The rotary cutter is top heavy when the wings arm raised. To avoid injury or death from rollover, use caution when transporting over uneven surfaces and slow down for turns.
- **Thrown Object Hazard.** For non-agricultural use, OSHA, ASAE, SAE, and ANSI standards require the use of chain shields or other protective guards at all times. DO NOT remove the chain shields.
- **Stay Clear.** Clear the work area of all unnecessary people and obstructions to prevent personal injury.
- **Cutter Blade Contact Hazard (Hand).** To avoid serious injury or death, keep away from rotating blades. Do not put hands under cutter deck.
- **Cutter Blade Contact Hazard (Foot).** To avoid serious injury or death, keep away from rotating blades. Do not put feet under rotary cutter deck.

- **Crush Hazard.** Hydraulic or mechanical failure can allow a wing to drop suddenly without warning. Do not allow anyone to walk under or stand near a raised wing when the wing locks are removed.
- **Entanglement Hazard.** Operating the rotary cutter without the driveline shields could result in physical injury or death from entanglement. Make sure all shields are properly installed before operating the rotary cutter. This equipment should never be operated with any safety shielding removed.



IMPORTANT



The following safety instructions are provided to help prevent injury or limit equipment damage.

Train Unfamiliar Users

- It is the rotary cutter owner's responsibility to make sure any person using the rotary cutter, especially if it is loaned or rented, has been thoroughly trained on its proper and safe use.
- Be certain only physically-able persons will use the rotary cutter.
- Users who have not read and understood all operating and safety instructions are not qualified to use the rotary cutter.
- If the elderly are assisting with the work, their physical limitations need to be recognized and accommodated.
- Never allow children to operate equipment.

Fire Hazard

Clippings are flammable. To reduce the risk of fire:

1. Do not operate near fires.
2. Keep the rotary cutter deck clear of clippings and debris.



SAFETY ALERT SYMBOL



Wing cutting blades may become locked together (overlapping) when the wings are raised for transport. Operating the cutter in this condition will result in severe deck vibration. Inspect the wings for locked blades prior to lowering the wings. Use a pry bar or other tool to free any locked blades.

4. Operation

4.2 Tractor Requirements



WARNING



TRACTOR OWNER/OPERATOR MANUAL

Always refer to the tractor owner's manual to ensure compatibility and maximum safety.

The tractor used to operate the cutter must have the power to lift, pull, and operate the Power Take Off (PTO) at the cutter's rated speed while traveling at a ground speed between 2 and 5 mph.

The power required to operate the cutter is determined by the tractor PTO horsepower. Operating the cutter with a tractor that does not have adequate power may damage the tractor engine.

MODEL	RECOMMENDED MINIMUM HP
403150	35 (Gear Drive Transmission)

Operating the cutter with a tractor that does not meet the following requirements may cause tractor or cutter damage and be a potential danger to the operator and passersby.

Always review the "controls" section of the tractor operator's manual to be familiar with the location, settings, and function of the tractor controls. Be familiar with all controls before using this equipment.

Equipment and Capabilities

- Approved Roll-Over Protective Structure (ROPS) or ROPS cab and seat belt.
- Tractor Safety Devices; Slow Moving Vehicle (SMV) emblem, lighting, PTO master shield.
- Front end weight, as needed, to maintain 20% weight on front axle.
- To reduce the risk of grass fires, do not operate the cutter on a tractor with an underframe exhaust.

Tractor Safety Devices

If transporting or operating the tractor and implement near a public roadway, the tractor must be equipped with proper warning lighting and a Slow Moving Vehicle (SMV) emblem which are visible from the rear of the unit. Lights and a SMV emblem must be attached directly to the implement if the visibility of the tractor warning signals are obscured.

Maintain all manufacturer equipped safety shields and guards. Always replace shields and guards that were removed for access to connect, service, or repair the tractor or implement. Never operate the tractor PTO with the PTO master shield missing or in the raised position.

ROPS and Seat Belt



WARNING



ROLLOVER HAZARD

To avoid serious injury or death from falling off tractor, equipment run over, rollover, or crushing:

1. Use ROPS equipped tractor.
2. Keep ROPS locked in the UP position.
3. Only operate the equipment when seated in the tractor seat.
4. Always fasten set belt when operating the tractor and rotary cutter.
5. The unit is top heavy when the wings are folded. Use caution when transporting over uneven terrain and slow down for turns.

The tractor must be equipped with a Roll Over Protective Structure (ROPS) (tractor cab or roll bar) and seat belt to protect the operator from falling off the tractor, especially during a roll-over where the driver could be crushed and killed. Only operate the tractor with the ROPS in the raised position and seat belt fastened.

4. Operation

4.2 Tractor Requirements Cont'd

Drawbar

The distance between the drawbar hitch pin hole and the end of tractor PTO shaft must be 14". The distance from the top of the drawbar to the PTO shaft must be 8". PTO damage may occur if this dimensions vary more than 1".

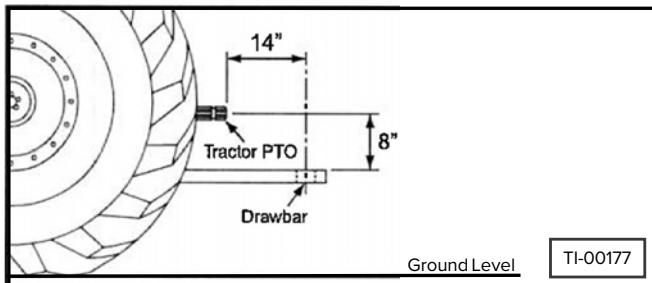

Power Take-Off (PTO)

This rotary cutter operates at a PTO speed of 540 RPM. Most tractors operate at either 540 or a combination of 540 and 1000 RPM PTO speeds. The operating speed of the tractor can be determined by the number of splines on the PTO output shaft. Those operating at 540 RPM will have a 6-spline shaft, and those operating at 1000 RPM will have a 20 or 21-spline shaft.

Refer to the tractor Operator's Manual for instructions to change PTO speeds on models that operate at more than one speed.

! IMPORTANT !

If operating an older model tractor where the tractor's transmission and PTO utilize one master clutch, an over-running clutch must be used between the PTO output shaft and the driveline of the rotary cutter. An authorized tractor dealer can provide the over-running clutch and its installation, if needed.

DO NOT use a PTO adapter to attach a non-matching implement driveline to a tractor PTO. Consult an authorized dealer for assistance if the implement driveline does not match the tractor PTO.



WARNING



CRUSH HAZARD

Use of a PTO adapter can cause excessive vibration, thrown objects, and blade and implement failure. Adapter use will also change the working length of the driveline, exposing unshielded driveline areas. Serious bodily injury or death can result from using a PTO adapter. DO NOT use a PTO adapter to attach a non-matching implement driveline to a tractor PTO.

4.3 Attaching to the Tractor

Use caution when connecting the rotary cutter to the tractor. The rotary cutter should be securely resting at ground level or setting on blocks. Keep hands and feet from under the deck and clear of pinch points between the tractor drawbar and rotary cutter hitch.



WARNING



CRUSH HAZARD

Crush hazard between hitch and implement. DO NOT allow anyone to stand between the hitch and implement during hook-up operations.

1. Use the jack to adjust the hitch to the height of the tractor drawbar.
2. Board the tractor and start the engine. Back the tractor up to the cutter hitch until the holes in the drawbar and clevis are aligned.
3. Turn off the tractor engine and dismount.

4. Operation

4.3 Attaching to the Tractor Cont'd

4. Insert a high strength drawbar pin through the clevis and drawbar holes and install retaining pin. Do not use a homemade or shop made pin.



WARNING



CRUSH HAZARD

Unexpected separation of the cutter from the tractor could cause death or serious injury. Use only an OEM high strength drawbar pin. Do not use a homemade or shop made pin.

5. Connect the hitch safety chain to the tractor drawbar cage. The safety chain should be long enough to allow for light turns, but not long enough to drag on the ground.
6. Retract the jack, remove the locking pin, move the jack to its storage location on the cutter deck, and secure it with the locking pin.
7. Pull back on collar (Item 1, below) on the tractor end of the driveline.

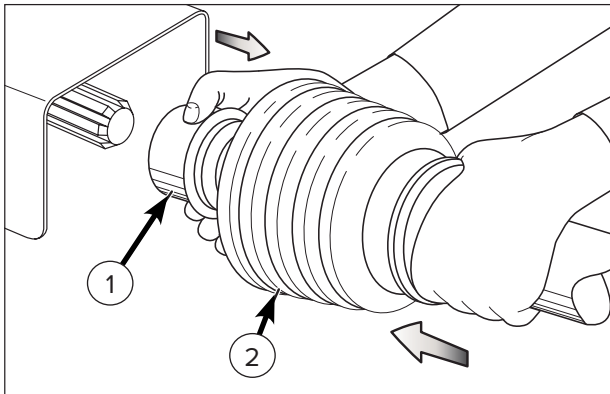

8. Push the driveline onto the tractor PTO shaft until the collar snaps forward as seen above.
9. Pull back on the driveline guard (Item 2, above) to check that the driveline is latched. Do not pull back on the collar as this will release the driveline.
10. Attach the safety chain on the driveline guard to the tractor.



WARNING



ENTANGLEMENT HAZARD

Operating the tractor PTO without the driveline shields could result in physical injury or death from entanglement. Make sure all driveline shields are properly installed before operating the PTO. Make sure all motion has stopped before attaching or detaching the driveline.

11. Inspect all the hydraulic hoses to ensure they are in good condition. Route the main lift hydraulic hose through the hose rack, make sure the fitting is clean, and attach to the tractor's hydraulic port. Make sure the hose is adequately supported so it cannot come in contact with other parts or the ground.



12. Make sure the driveline has adequate clearance through the full range of cutter height adjustment. Adjust tractor drawbar and/or length if there is interference. See section 4.5 Checking the Driveline Length on page 17.

4. Operation

4.4 Setting the Rotary Cutter

Properly setting the rotary cutter is essential for efficient and safe operation. A properly set rotary cutter will make a more uniform cut, distribute clippings more evenly, require minimal tractor work, and follow the contour of uneven terrain. The two adjustments to make before cutting are:

- Leveling front-to-back
- Cutting height



Avoid very low cutting heights. Striking the ground with the blades causes damaging shock loads and will cause damage to the rotary cutter and drive.



PROJECTILE HAZARD

Blades contacting the ground may cause objects to be thrown out from under the cutter deck. Do not operate the rotary cutter at a height which causes the blades to contact the ground.

Leveling Front-to-Back

1. Locate the tractor and cutter on a flat, level surface and use the hydraulics to adjust the cutter height until the front skid shoes are two to three inches off the ground.
2. Shorten or lengthen the leveling rods, as needed, to obtain the desired cutting results. Lengthening the leveling rods raises the back of the cutter.

A. Operating the rotary cutter with the deck approximately 3/4" higher in the rear than the front will allow the rotary cutter to cut the grass only once and requires less work from the tractor.

B. Operating the rotary cutter with the deck approximately 3/4" higher in the front than the rear will increase mulching of the grass or crop material.

C. Operating the rotary cutter at any position other than level with the ground will result in a slightly uneven cut.

3. Make sure the leveling rods have equal amounts of tension, and tighten the adjuster jam nuts.

Setting the Cutting Height

The rotary cutter should be operated at the highest position that will give the desired cutting results. This will help prevent the blades from striking the ground, increasing blade life, and reducing stress on the rotary cutter and tractor.

1. Park the tractor and rotary cutter on level ground.
2. Using the tractor hydraulic cylinder control lever, position the front of the center deck with the center skid shoes 1" lower than the desired cut height. For example, for a 3" cut, position the skid shoes 2" from the ground. Set the control lever stop at this position to maintain this height when raising and lowering the cutter.
3. Check the wing decks and re-level them if needed. Refer to Section 3.4 Leveling the Wing Decks on page 14.

4. Operation

4.4 Setting the Rotary Cutter Cont'd

Wing Stop Adjustment

When raised, the wings should contact the stops when the wing lock hole is aligned with the pin. If adjustment is necessary:

1. Raise the wings with the tractor hydraulics and install the wing locks.

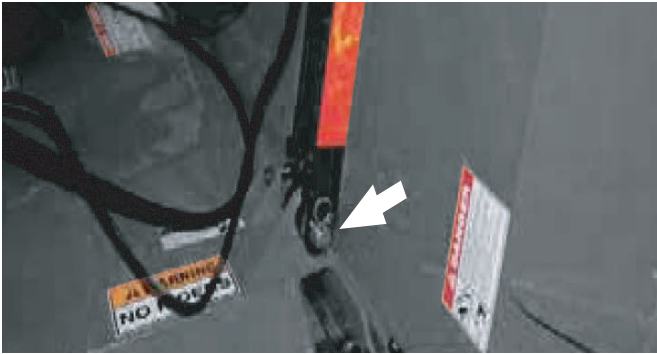

2. Loosen the lock nuts on the wing stop bolt on one wing, and make sure the wing stop bolt does not touch the wing.

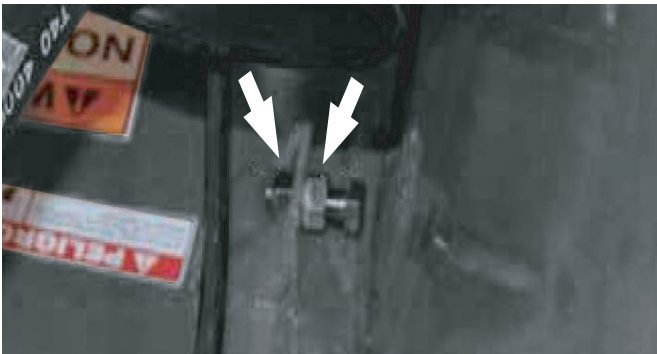





3. Adjust the lock nuts so that the wing stop bolt contacts the raised wing.
4. Tighten the lock nuts.
5. Repeat steps 2–4 for the other wing.

4.5 Inspection Checklist



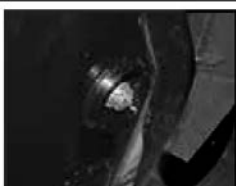

Efficient and safe operation of the rotary cutter requires that every user read and understand the operational instructions and all related safety instructions outlined in this manual.

This checklist is provided for the user/owner. It is important for both personal safety and to maintain the mechanical condition of the rotary cutter that this checklist is followed.

✓	Location	Task
		Verify all safety signs are in place and legible. Refer to Section 8.15 Safety Sign Locations on page 63.
		Make sure the rotary cutter is properly attached to the drawbar. Refer to section 4.3 Attaching to Tractor on page 21.
		Make sure the driveline is attached to the tractor PTO and safety chains are installed. Refer to section 4.3 Attaching to Tractor on page 21.
		Make sure all hardware is properly installed and tightened. Refer to 7.7 Bolt Torque Requirements on page 40.
		Make sure the blades are sharp. Refer to 7.4 Blade Maintenance on page 36.
		Make sure the blade carrier nuts are tight and the cotter pins installed. Refer to 7.5 Blade Carrier on page 38.

4. Operation

4.5 Inspection Checklist Cont'd

✓	Location	Task
	 	Lubricate all grease zerks and driveline slip joints. Refer to section 7.3 Lubrication on page 35.
		Make sure all safety shields and guards are properly installed. Refer to section 3.2 Assembly Procedure on page 12.
		Check the tail wheels for damage. Make sure the tail wheel support bolts are tight.
		Check the cutting height. Adjust if needed. Refer to section 4.4 Setting the Rotary Cutter on page 23.

4.6 Machine Break-In

Although there are no operational restrictions on the rotary cutter when used for the first time, it is recommended that the following mechanical items be checked:

1. After 1/2 hour of operation:
 - a. Tighten all fasteners if necessary
 - b. Lubricate all grease fittings.
2. After 10 hours of operation:
 - a. Go to the normal servicing and maintenance schedule, as defined in the Maintenance Section.

4.7 Pre-Operation Checklist

Before each use of the rotary cutter, the following areas should be checked.

	ITEMS
✓	Make sure the rotary cutter is positively attached to the tractor drawbar. Refer to section 4.3 Attaching to Tractor on page 21.
✓	Make sure the hydraulic hoses are undamaged, are secured on the hose rack, and cannot contact the tractor when turning or dragging on the ground.
✓	Use only an appropriately-sized tractor to pull the rotary cutter. Refer to section 4.2 Tractor Requirements on page 20.
✓	Make sure the driveline is securely attached to the tractor PTO. Refer to section 4.3 Attaching to Tractor on page 21.
✓	Make sure all safety shields and guards are properly installed.
✓	Check the blade bolts and blade carrier nuts. Refer to section 7.4 Blade Maintenance on page 36.
✓	Inspect wing blade carriers and blades for locked blades prior to lowering the wings. Use a pry bar or other tool to separate locked blades.
✓	Check the condition of the blades.
✓	Check the cutting height. Adjust if needed. Refer to section 4.4 Setting the Rotary Cutter on page 23.
✓	Inspect the overall rotary cutter for potential problems or damage. Do not use the rotary cutter if it needs repairs of any type.
✓	Make sure the driveline CV joint, U-joints, and slip joints are greased. Refer to Driveline Lubrication on page 35.

4. Operation

4.8 General Operating Procedure

Although the rotary cutter is easy to use, each operator should review this section to familiarize themselves with the detailed safety and operating procedures.

1. Operate the rotary cutter only in conditions where you have clear visibility in daylight or with adequate artificial lighting. Never operate the rotary cutter in darkness or foggy conditions where you cannot clearly see at least 300 feet in front and to the sides of the tractor and rotary cutter. Make sure that you can clearly see and identify passersby, steep slopes, ditches, drop-offs, overhead obstructions, debris, and foreign objects. If you are unable to clearly see these type of items, discontinue operating the cutter.
2. Clear the area of bystanders, especially small children.
3. Clear the area to be cut of stones, branches, debris, and any hard objects that may be thrown. Also remove objects such as wire, cable, rope, or chains that can become entangled in the blades. Never operate the rotary cutter in an area that you have not inspected and removed debris or foreign material. Mark the location of objects that cannot be removed.



WARNING



CRUSH HAZARD

Objects such as wire, cable, rope, or chains can be entangled in the rotating parts of the cutter. These items could then swing outside the deck at greater velocities than the blades. This is extremely hazardous and could result in serious injury or even death. Inspect the cutting area for such objects before mowing, and remove them. Never allow the blades to contact such items.

4. Do not operate the rotary cutter, or drive the tractor into material that is burning, or areas that recently burnt and may contain hot spots. Burning material, sparks, and coals could be thrown from the rotary cutter to areas of vegetation that might ignite. Tire damage can occur when driving over hot material. Oil and grease on the tractor and rotary cutter could ignite, resulting in equipment destruction. Carry a fire extinguisher on the tractor at all times to extinguish possible fires encountered. Do not operate the rotary cutter on a tractor with an underframe exhaust.
5. Whenever using a rotary cutter in dry grass, be aware that a thrown metal object can create a spark against a thrown metal object can create a spark against the blade or metal deck housing. Take extra precautions in this type of dry situation to prevent fires.



WARNING



THROWN OBJECT HAZARD

Operating the PTO with a wing in the folded position could cause the driveline to break and throw objects at the operator or a bystander causing serious injury or death. Do not engage the PTO with either wing folded up.

6. Engage the PTO at low engine RPM, then raise PTO speed to 540 RPM.
7. Begin cutting at a slow speed, then increase to a speed that gives a clean cut without lugging the engine. Do not operate above 5 mph.
8. Never allow blades to contact solid objects like rocks, posts, wire, curbs, guardrails, or the ground while mowing.
9. When you get to the end of a pass, slightly raise the rotary cutter (2-4") before turning. Never raise the rotary cutter entirely while the blades are turning. If the rotary cutter must be raised higher than 12" from ground level, disengage the tractor PTO and wait for all blade rotation to come to a complete stop before raising the rotary cutter.

4. Operation

4.8 General Operating Procedure Cont'd

10. When turning, the angle between the tractor and rotary cutter must not exceed 80°. This extreme angle is intended for intermittent use only. Plan your cutting to minimize extreme turning angles. Sharp turns can cause premature failure of the joints and put pressure on the tractor PTO shaft, and could cause extensive mechanical damage to the rotary cutter and tractor.
11. When making tight turns, ensure that the tractor tires and lower 3-point arms do not make contact with the cutter. Keep the 3-point hitch raised whenever the tractor is hitched to a pull-type cutter.
12. Do not operate a pull-type cutter at an angle exceeding 25 degrees up or down or at any angle that will force the driveline to bind and/or hit the tractor drawbar.
13. Large, dense, or wet vegetation may need to be cut in two or more passes to achieve a uniform cut. In such conditions, raise the cutting height to 12" or more on the first pass. Then lower the rotary cutter to the desired height and mow the vegetation a second time. If possible, select a cutting direction that is at a 90 degree angle to the first pass to reduce streaking for a more uniform cut.
14. Stay alert and watch for trees, low hanging limbs, power lines, and other overhead obstacles while operating. Use care to avoid hitting these items.
15. Avoid cutting in reverse. Instead, disengage the PTO, wait for the blades to stop, and raise the deck. Back up into the area to be cut. Lower the deck, engage the PTO, and cut forward. Do not back the rotary cutter into solid objects. The joint where the hitch attaches to the deck will pivot upward, allowing the front edge of the deck to contact the driveline. Check to make sure there are no persons behind the rotary cutter, and use extreme care when maneuvering in reverse.

16. Always cross steep ditches and banks at a diagonal. Never cross straight across and never back into a steep ditch or bank. Cutting over ditches and backing up hills can "Bottom Out" the driveline. Bottoming out is when the driveline shaft has shortened to the point it is pressing against the gearbox and tractor PTO shafts. Once a driveline has bottomed out, it cannot be shortened anymore without causing serious damage to the tractor PTO components, cutter gearbox, and driveline.

4.9 Chain Shielding

Blue Diamond installs full chain shielding as standard equipment on all flex-wing rotary cutters.



WARNING



PROJECTILE HAZARD

The chain shielding is designed to reduce the risk of thrown objects.

The rotary cutter design and protective devices cannot prevent all objects from escaping the blade enclosure in every mowing condition. It is possible for objects to ricochet and escape, traveling as much as 300 feet.

Death or serious injury could result from being struck by a thrown object. Do not operate the cutter if the chain shielding is missing or damaged.

1. Full chain shielding must be installed when operating in populated areas or other areas where thrown objects could injure people or damage property.
2. If the chain shielding is missing or damaged, operation must be stopped until it can be repaired or replaced.
3. Inspect chain shielding each day of operation and replace any broken or missing chains, as required.

4. Operation

4.10 Right of Way (Roadway) Mowing

Use double chain shields for highway, right-of-way, parks, greenbelt mowing, or all other mowing where human dwellings, vehicles, or livestock could be within 300 feet of the cutter.

No shielding is 100% in preventing thrown objects. To reduce the possibility of injury:

1. Maintain rotary cutter shielding in good operational condition.
2. Inspect the condition of the thrown object guards, cutter side skirts, and skid shoes daily: Replace or repair worn or damaged guards.
3. Inspect the condition of the blades and blade bolts daily. Replace any cracked, worn, bent, or damaged blades. Always replace blade bolts and lock washers when replacing blades. Make sure the blade bolts are properly tightened.
4. Raise cutting height to 6" minimum.
5. Never allow blades to contact solid objects like rocks, posts, wire, curbs, guardrails, or the ground while mowing.

Rotary cutters can throw objects 300 feet or more under certain conditions. To avoid serious injury or death from thrown objects:

1. Inspect the area thoroughly for potential thrown objects and remove them before cutting.
2. Remove debris, rocks, wire, cable, metal objects, and other foreign material from the area.
3. Wire, cable, rope, chains, and metal objects can be thrown or swung outside the deck with great velocity.
4. Mark the location of objects that cannot be removed.

Stop mowing if passerbys are within 300 feet unless:

1. All thrown object shielding, including front and rear deflectors, chain shields, steel guards, bands, side skirts, and skid shoes are in place and in good condition when mowing.

2. Mower sections or wings are adjusted to be close and parallel to ground without exposing blades.
3. Mowing area has been inspected and foreign materials and debris have been removed.
4. Passersby are inside an enclosed vehicle.

4.11 Detaching from Tractor

1. Disengage the PTO and wait for blade rotation to come to a complete stop. Raise the rotary cutter with the tractor hydraulics, and install the transport lock on the lift cylinders.
2. Raise the wings with the tractor hydraulics and install the wing locks.



WARNING



CRUSH HAZARD

Hydraulic or mechanical failure can allow a wing to drop suddenly without warning. Do not allow anyone to walk under or stand near a raised wing when the locks are removed.

3. Park the tractor, place the transmission in park or neutral, and apply the parking brake. Lower the rotary cutter onto blocks placed under the front skid shoes. Shut down the engine, remove the key, and move the cylinder operating lever in both directions to relieve hydraulic pressure. Wait for all motion to come to a complete stop before exiting the tractor.
4. Make sure the rotary cutter is resting securely on the ground or blocks, and chock the cutter wheels before attempting to disconnect it from the tractor. Use extreme care to keep feet and hands from under the rotary cutter and clear or any pinch points caused by the tractor drawbar and rotary cutter hitch.
5. Remove the jack from the cutter deck and secure it to the hitch by fully inserting the locking pin through the jack and the hitch bracket. Use the jack to raise the cutter hitch to the height needed to disconnect the clevis from the drawbar.

4. Operation

4.11 Detaching from Tractor Cont'd

6. Disconnect the hydraulic hose from the tractor.
Store the hose on the cutter deck.



CAUTION



EXPLOSIVE SEPARATION HAZARD

Be sure all hydraulic pressure is relieved before disconnecting hydraulic lines or fittings between the rotary cutter and the tractor hydraulic system. Escaping hydraulic fluid under pressure, even a pinhole size leak, can penetrate body tissue, causing serious injury and possible death. If fluid is injected into your skin, it must be treated immediately by a doctor familiar with this type of injury.

7. Disconnect the driveline safety chain and hitch safety chain.
8. Pull back on the collar on the tractor end of the driveline.

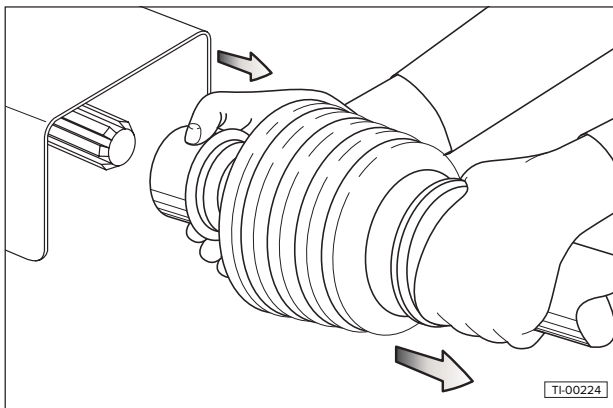

9. Slide the driveline off the tractor PTO shaft and secure it up off the ground.
10. Remove the hitch pin and drive the tractor away from the rotary cutter.

5. Transporting

5.1 Transporting Safety (Road)



WARNING



Failure to comply with the following safety instructions could result in serious injury and possibly even death if they are not understood and followed.

- **Tractor Owner/Operator Manual.** Always refer to the tractor owner's manual to determine its compatibility and maximum safety.
- **Operating the Tractor.** Before attaching the rotary cutter to the tractor, be familiar with its controls and how to stop it quickly in the event of an emergency. Read and understand this manual and the one provided with your tractor before transporting the rotary cutter.
- **Fail and Crush Hazard.** Do not allow riders on the rotary cutter or tractor.
- **Maximum Transporting Speed.** Do not exceed 15 mph when transporting the rotary cutter. Slow down for corners and rough terrain.
- **Visibility.** Clean reflectors, SMV or SIS sign, and tractor tail lights before towing. Make sure all the lights and reflectors required by highway and transport authorities are in place and can be seen clearly by all overtaking and oncoming traffic.
- **Regulations.** Make sure all local, state, and federal regulations, regarding the transport of equipment on public roads and highways, are met. Check with the local authorities regarding transporting the rotary cutter on public roads. Obey all applicable laws and regulations.
- **Rollover Protection.** The tractor should be equipped with a Roll Over Protective Structure (ROPS) and a seat belt. The cutter is top heavy when the wings are folded. Use caution when transporting over uneven surfaces and slow down for turns.



IMPORTANT



SAFETY ALERT SYMBOL



The following safety instructions are provided to help prevent injury or limit equipment damage.

- **Drive Safely.** Be a safe and courteous driver. Anticipate what other drivers will do and drive accordingly.
- **Allow Extra Distance.** Apply brakes early. Leave extra distance between your vehicle and the one(s) ahead to provide adequate stopping space. Extra distance will be required to stop the vehicle.
- **Clear Vision.** Remove all objects from the area that would prevent clear vision of the complete work area or would present an obstacle when moving the rotary cutter.
- **Hitch Attachment.** Be sure the rotary cutter is securely attached to the tractor and in good operating condition before using.
- **Working Taillights.** Make sure lights on the tractor are working properly.
- **Additional Lighting.** For rotary cutters without lights, install additional lights on the rear of the tractor to safeguard against rear-end collisions. Daybreak and dusk are particularly dangerous and rear pilot vehicles are recommended. Rotary cutters without lights should be transported on public roads only during daylight hours.
- **Hazard Flashers.** Use hazard flashers on the tractor when transporting unless prohibited by law.
- **Right-Of-Way.** When traveling below the posted speed limit, keep to the right and yield the right-of-way to allow faster traffic to pass.

NOTE: Laminated sectional tires are designed for conditions where puncture-proof performance is required and the rotary cutter will not be transported for long distances on roadways. Transport speed for laminated tires should not exceed 15 mph. Excessive speed can cause damage to the machine and tire sections.

5. Transporting

5.2 Transporting Procedure

1. Make sure the towing safety chain on the rotary cutter hitch is attached to the tractor drawbar cage. The safety chain should be long enough for tight turns. Don't allow the chain to drag on the pavement because it will wear the chain links, causing an unsafe condition.
2. Prior to towing, make sure the brakes, brake lights, running lights, turn signals, and hazard lights on the tractor are operating correctly.
3. Raise the rotary cutter with the tractor hydraulics. Place the transport lock over the wheel lift cylinder rod. Insert and lock the retaining pin.
4. Make sure the jack stand is secured in its storage location on the left wing deck.

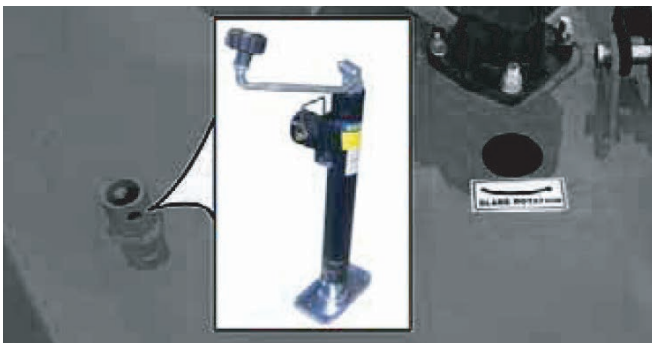

WARNING



THROWN OBJECT HAZARD

Operating the PTO with a wing in the folded position can cause the driveline to break and throw objects at the operator or a bystander causing serious injury or death. Before folding the wings, make sure the PTO is disengaged and all blade movement has stopped. Do not engage the PTO with either wing folded up.

5. Fold the wings onto the wing rests.



NOTE: The center deck will raise fully up before the wing cylinders start to fold the wings.



WARNING



PINCH POINT HAZARD

DO NOT place hands or fingers between moving and/or stationary parts. The weight of the unit could easily cause serious bodily injury.

CRASH HAZARD

After raising the wings, make sure to install both wing locks.

6. Install the wing lock bars and their retaining pins.

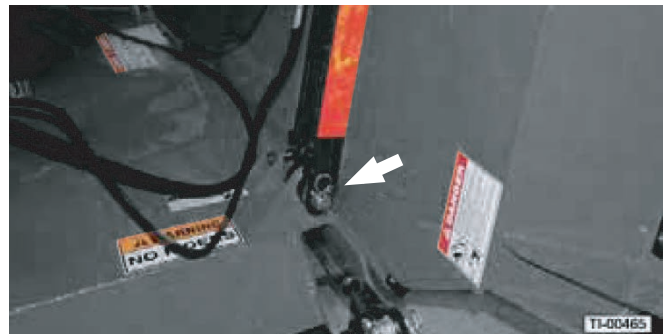

WARNING



CRUSH HAZARD

The rotary cutter is top heavy when the wings are raised. To avoid injury or death from rollover, use caution when transporting over uneven surfaces and slow down for turns.

7. Tow the cutter to the work site following all applicable regulations and all the safety instructions in this manual.

6. Storage

6.1 Storage Safety

At the end of the season, the rotary cutter should be thoroughly inspected and prepared for storage. Repair or replace any worn or damaged components to prevent any unnecessary downtime at the beginning of the next season.



WARNING



ROLLOVER HAZARD

The rotary cutter is top heavy when the wings are raised. To avoid injury or death from rollover, store the cutter on a firm, level surface.



CAUTION



PERSONAL INJURY HAZARD

Store the rotary cutter in an area way from human activity. To prevent the possibility of serious injury, do not permit children to play on or around the stored rotary cutter.



IMPORTANT



To prevent damage to the rotary cutter, store it in a dry, level area.

6.2 Placing in Storage

1. Remove all entangled vegetation.
2. Thoroughly wash the rotary cutter with a pressure washer or water hose to remove all clippings, dirt, mud, or debris.
3. Raise the rotary cutter with the tractor hydraulics and install the transport lock on the lift cylinder.
4. Raise the wings with the tractor hydraulics and install the wing lock bars and their retaining pins.

5. Select an area that is dry, level, and free of debris (inside a building is ideal). Move the rotary cutter to its storage area. Disconnect the rotary cutter from the tractor following the procedure in section 4.11 Detaching from Tractor on page 28.
6. Lubricate all grease points. Make sure all grease cavities have been filled with grease to remove any remaining water from washing.
7. Touch up all paint nicks and scratches to prevent rusting.

6.3 Removing from Storage

1. Grease all lubrication points. See section 7.3 Greasing on page 35.
2. Attach the rotary cutter to the tractor following the procedure in section 4.3 Attaching to the Tractor on page 21.



IMPORTANT



Wing cutting blades may become locked together (overlapped) when the wings are raised for transport or storage. Operating the cutter in this condition will result in severe deck vibration. Inspect the wings for locked blades prior to lowering the wings. Use a pry bar or other tool to free any locked blades.

3. Check for locked blades before lowering the wings. Use a pry bar or similar tool to free any locked blades.
4. Before placing the rotary cutter back into service, replace any worn or defective parts and perform the Pre-Operation Checklist found in section 4.7 on page 25.
5. Check the operation of the slip clutches. Refer to section Slip Clutch Operational Check on page 38.

7. Service and Maintenance

7.1 Maintenance Safety



WARNING



Failure to comply with the following safety instructions could result in serious injury and possibly even death if they are not understood and followed.

- **Personal Protection Equipment.** Wear close fitting and belted clothing to avoid getting caught in moving parts. Wear personal protection equipment (PPE), which may include hard hat, safety glasses, safety shoes, gloves, etc. appropriate for the work site and working conditions.
- **Disconnect Driveline.** To prevent injury due to possible unexpectedly movement, disconnect the driveline from the tractor PTO before performing any maintenance procedure.
- **Damaged Parts Hazard.** DO NOT use the rotary cutter if any parts are damaged. If the rotary cutter is believed to have a defect which could cause it to work improperly, immediately stop using it and remedy the problem before continuing.
- **No Unauthorized Modifications.** DO NOT modify the rotary cutter or safety devices. DO NOT weld on the unit. Unauthorized modifications may impair the cutter's function, or create safety hazards, and will void the warranty.
If the rotary cutter has been altered in any way from the original design, the manufacturer does not accept any liability for injury or warranty.
- **Crush Hazard.** Always set the rotary cutter on safety stands or on the ground and chock the wheels when performing maintenance.
- **Good Working Condition.** Keep all parts in good condition and properly installed. Fix damage immediately. Replace worn or broken parts.
- **Replacement Parts.** If replacement parts are necessary, genuine factory replacement parts must be used to restore the unit to its original specifications. Unapproved parts could create a safety hazard. The manufacturer will not accept responsibility for damages as a result of the use of unapproved parts.
- **Safety Shields and Devices.** When completing a maintenance or service function, make sure all safety shields and devices are installed before placing the rotary cutter in service.
- **Crush Hazard.** The wings may drop unexpectedly if the wing locks are not installed. To avoid serious injury or death from crushing, always make sure the lock bars and their retaining pins are properly installed whenever the wings are raised.
The rotary cutter is top heavy when the wings are raised. To avoid injury or death from rollover, make sure the cutter is on a firm, level surface.
- **Trapped Air Hazard.** When installing, replacing, or repairing hydraulic system cylinders or parts, make sure that the entire system is charged and free of air before resuming operations. Failure to bleed the system of all air can result in improper machine operation, causing severe injury.
- **Zero Pressure.** Relieve pressure from the hydraulic system before servicing or disconnecting from the tractor.
- **Explosive Separation Hazard.** Replace any worn, cut, abraded, flattened, or crimped hoses.

7. Service and Maintenance

7.1 Maintenance Safety Cont'd

- **High-Pressure Fluid Hazard.** Keep all hydraulic lines, fittings, and couplers tightly secured and free of leaks.
DO NOT make any temporary repairs to the hydraulic lines, fittings, or hoses using tape, clamps, or cement. The hydraulic system operates under extremely high pressure and temporary repairs may fail suddenly and create a hazardous/dangerous situation.
DO NOT use your bare hand to check for potential leaks. Always use a board or cardboard when checking for a leak.
Escaping hydraulic fluid under pressure, even a pinhole size leak, can penetrate body tissue, causing serious injury and possible death. If fluid is injected into your skin, it must be treated immediately by a doctor familiar with this type of injury.

 **IMPORTANT** 

 **SAFETY ALERT SYMBOL** 

The following safety instructions are provided to help prevent injury or limit equipment damage.

- **Safety Equipment.** A fire extinguisher and first aid should be readily accessible while performing maintenance on this equipment.
- **Clean Work Area.** DO NOT leave tools lying around the work area. Follow good shop practices. Keep service area clean and dry. Be sure electrical outlets and tools are properly grounded. Use adequate light.
- **Use the Right Tools.** Use the correct tools, jacks, hoists, or other tools that have the capacity for the job.
- **Proper Support.** Use certified safety stands rated to support the load when working beneath the rotary cutter, or performing repairs, service, or maintenance.
The rotary cutter weights 2630 lbs. Before working underneath, place it on a minimum of four jack stands, with a load rating of at least 2000 lbs each.

Do not position the jack stands under wheels, axles, or wheel supports, as they may rotate and cause the rotary cutter to fall.

Make sure the jack stands are stable and the rotary cutter deck is approximately level. Test the stability of the rotary cutter before working underneath.

If the rotary cutter is attached to the tractor, set the brakes, remove the key, chock the tractor wheels, and block the rotary cutter before working underneath.

7.2 Welding Safety

Before performing any type of welding repair to the rotary cutter, contact Blue Diamond for approval. Repair welding must be done with care and with procedures that may be beyond the capabilities of the ordinary welder.



WARNING



PROJECTILE HAZARD

DO NOT attempt to weld on the blades. They are hardened and will crack or otherwise be damaged, causing failure and possible serious injury or death from thrown blades.

PERSONAL INJURY HAZARD

Repairs or modifications to the rotary cutter can result in serious injury or death should these repairs fail.

 **IMPORTANT** 

Anyone performing a welding repair should be certified in accordance to the American Welding Society (AWS) standards.

7. Service and Maintenance

7.3 Lubrication

Greasing Locations

See the diagram below for the location of all the grease zerks.

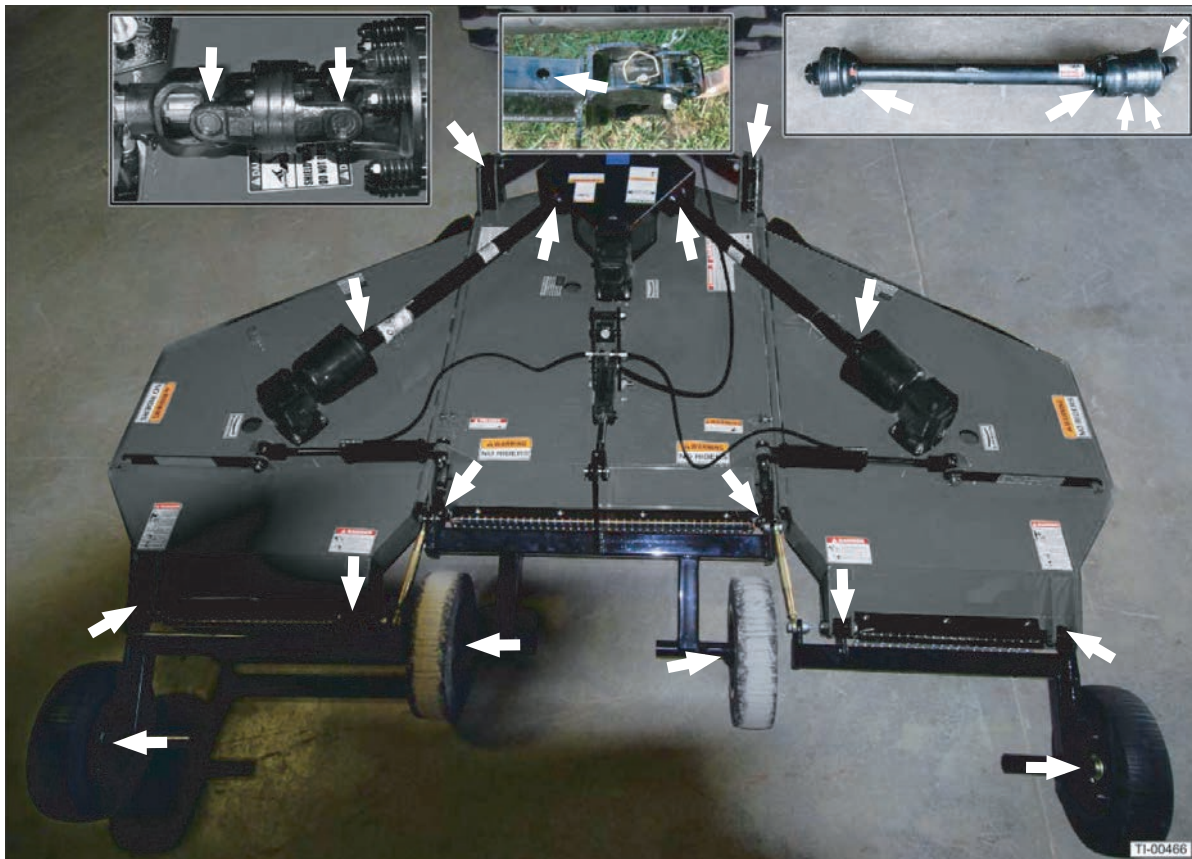

Grease all zerks according to section 7.3 on page 35. Use an SAE multipurpose high-temperature grease with extreme pressure (EP) performance. An SAE multipurpose lithium base grease is also acceptable.

LOCATION	QTY
Receiver Swivel	1
Hitch Pivot Bushings	2
Front Driveline CV Joint	2
Front Driveline U-Joints	3
Wing Driveline U-Joints	3
Splitter Cross Shaft U-Joints	2
Tailwheel Tube Pivot Bushings	6
Tailwheel Hubs	4

- Always use a handheld grease gun for all greasing.
- Wipe grease zerks with a clean cloth before greasing to avoid injecting dirt and grit.
- Apply grease until new grease can be seen coming out of the joint.
- Do not let excess grease collect on or around part, particularly when operating in sandy areas.
- Replace broken grease zerks immediately.
- If any grease zerk will not take grease, remove and clean it thoroughly. Also clean the lubricant passageway. Replace the zerk if necessary.

7. Service and Maintenance

7.3 Lubrication Cont'd

Gearbox Lubrication

The gearbox is filled at the factory and should require no maintenance. If there is evidence of leakage, the oil level should be checked. If required, oil should be added until it comes to the proper level.

Recommended lubricant is SAE140 gear oil.

NOTE: Make sure the rotary cutter is level when checking the oil in the gearbox.

NOTE: Fill until level reaches the bottom of the inspection hole. Overfilling the gearbox will cause pressure to build up and cause the seals to leak.

SPECIFICATION	RH GEARBOX	LH GEARBOX
Weight	60-lbs	
Oil/Grease Level (Oz)	56 oz (1.32 qt)	
Gearbox Description	Comer (9.240.805.00) RH Wing	Comer (9.240.802.00) LH Wing
Usage Output Rotation	12-ft (CCW)	
Input Shaft Diameter	1-3/8" 6-Spline	
Output Shaft Diameter	1-1/2" 12-Spline	
Ratio	1:1.71	
RPM	540-rpm	

Driveline Lubrication

Lubricate all driveline slip joints, U-joint crosses, and the center driveline CV joint every eight operating hours.

1. Lower the rotary cutter to the ground, disconnect the center driveline from the tractor PTO shaft, and slide the halves apart but do not disconnect from each other.

2. Apply a bead of grease completely around the male half where it meets the female half. Slide the drive halves over each other several times to distribute the grease.
3. Remove the splitter gearbox shield and disconnect the wing drivelines from the splitter gearbox.
4. Repeat Step 2 for each wing driveline.
5. Rotate the front driveline safety shield until the holes in the shield match up with the grease zerks in the CV joint and U-joint.
6. Apply grease to all accessible grease zerks.
7. Rotate the driveline shield 180° until the holes on the opposite side align with the remaining grease zerks and apply grease.
8. Repeat for the U-joint at the rear of the center driveline and at both ends of the wing drivelines.
9. Grease the zerks on the splitter cross shaft.
10. Reconnect the drivelines and reinstall the splitter gearbox shield.

7.4 Blade Maintenance

Blade Servicing

Inspect the blades before each use to determine that they are properly installed and in good condition. If any blade is bent, excessively nicked, worn, or has any other damage, replace both blades on the spindle. Small nicks can be ground out when sharpening.

Manually rock the blade carriers to check for any looseness. Recheck torque every **50 hours**. Retighten any loose parts.

7. Service and Maintenance

7.4 Blade Maintenance Cont'd

Blade Removal

To remove the blades for sharpening or replacement, remove the nut and lock washer from the blade bolt through the inspection hold in the deck of the mower near the gearbox.

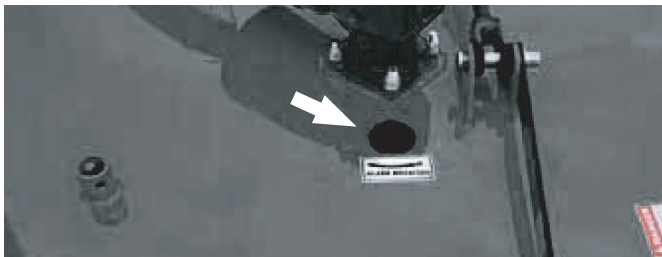

Blade Installation

When installing blades, be sure to check the blade bolt pivot diameter for wear. Replace the bolt if worn. Tighten the nut to 600 ft. lbs.

Always use a new lockwasher and nut when replacing the blade bolt.

Make sure the blades are installed with the cutting edge in the direction of rotation. The left and center spindles rotate counterclockwise as viewed from above the deck. The right spindle rotates clockwise as viewed from above the deck.

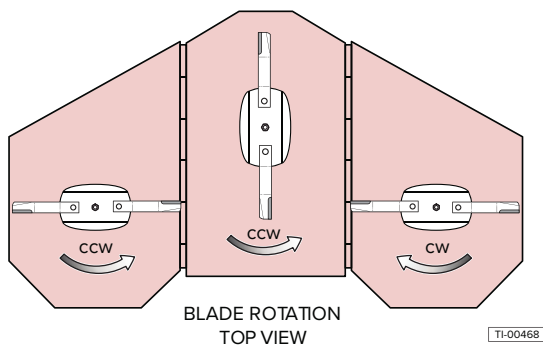

Blade Sharpening



CAUTION



SHARP OBJECT HAZARD

The grinder may catch on the blade during sharpening, propelling it forcefully. To prevent the possibility of serious injury, make sure blades are secured against movement while sharpening.

When sharpening blades, always sharpen both blades at the same time and grind the same amount on each blade to maintain balance.



IMPORTANT



Unbalanced blades will cause excessive vibration, which can damage gearbox bearings. Vibration may also cause structural cracks to the rotary cutter.

Follow the original sharpening pattern. Do not sharpen blades to a razor edge; leave a 1/16" blunt edge. Do not sharpen the back side of the blade. Do not heat and pound out the edge.

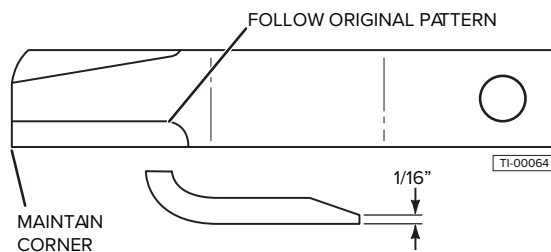

Replace the blades when worn more than 1/2" from the original edge. Always replace blades in pairs.

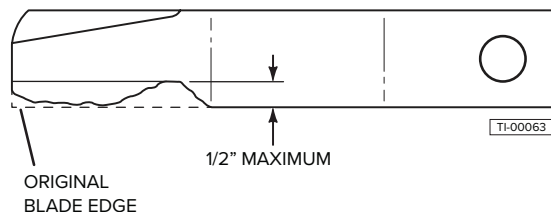

7. Service and Maintenance

7.5 Blade Carrier

Blade Carrier Removal

1. Remove the cotter pin and loosen the castle nut on the gearbox shaft. Do not remove the nut until the blade carrier is loosened.
2. Use a suitable two jaw gear puller to pull the carrier off the tapered gearbox shaft.
3. If a gear puller is not available, insert a bar through the blade bolt access hole with the end against the blade carrier. Strike the opposite end of the bar sharply. Rotate the blade carrier 180 degrees and repeat until the carrier breaks loose.
4. Remove the castle nut and the blade carrier.

Blade Carrier Installation

1. Clean the splines on both the blade carrier and the output shaft.
2. Position the carrier on the gearbox output shaft and install the castle nut. Tighten the nut to 450 ft. lbs
3. Strike the carrier near the hub several times with a heavy hammer to seat the hub. Use care not to strike the nut or the end of the shaft.
4. Retighten the nut to 700 ft. lbs.
5. Install the cotter pin and spread the tangs.

7.6 Slip Clutch Maintenance

Slip Clutch Operational Check

The rotary cutter is equipped with three slip clutches, with one located in front of each spindle gearbox. The slip clutches serve as overall protection for the tractor driveline, and gearboxes. If the slip clutches have been exposed to weather for an extended period of time, the clutch facing and plates should be inspected for rust and/or corrosion, which may inhibit function. After the rotary cutter has been stored for thirty days or more, perform the following check:

1. Mark a pencil line across the edges of the clutch plates and friction discs.

2. Loosen the eight nuts holding the clutch springs exactly two full turns. Hold the bolt so that it does not turn.

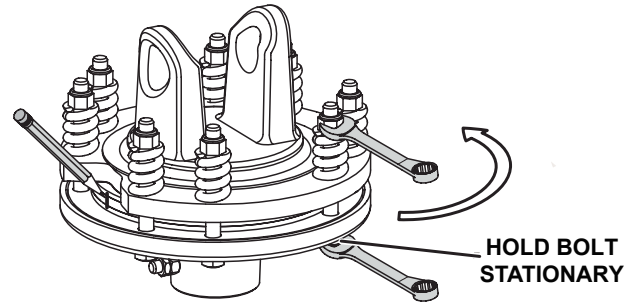

3. Start the tractor and engage the tractor PTO drive for 2-3 seconds. Disengage the PTO, then re-engage for an additional 2-3 seconds. The clutch should slip without turning the blades. Disengage the PTO, shut down the engine, remove the key, and wait for all motion to come to a complete stop before exiting the tractor.
4. Verify that the pencil lines have changed position. If the marks are still aligned, the clutch did not slip. If the clutch did not slip, it will need to be disassembled to separate the clutch plates from the friction discs. See “Slip Clutch Disassembly/Assembly” on page 39.
5. Retighten the eight nuts to the original position.



Incorrect slip clutch torque settings may cause damage to the cutter and/or tractor. Be sure to retighten the nuts to their original position.

NOTE: Check each clutch periodically during the first hour of operation for excessive heat build-up due to unexpected slippage.

7. Service and Maintenance

7.6 Slip Clutch Maintenance Cont'd

Slip Clutch Adjustment

The slip clutches are factory preset to the correct torque for protecting the implement and tractor. Periodic adjustment is recommended. Should adjustment be needed, follow this procedure:

1. Check to be sure all spring lengths are the same. Initial spring length is shown in the chart.

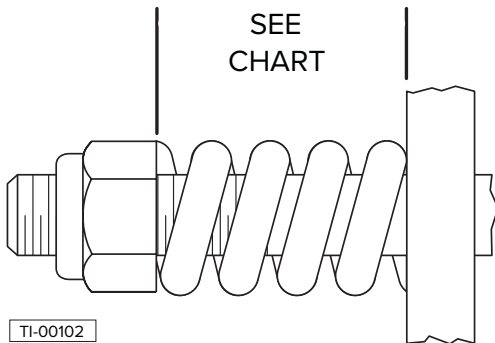

CLUTCH SPRINGS LENGTH CHART	
EG / COMER	BONDIOLI & PAVESI
1.27" (32.2mm)	1.15" (29.3mm)
1.28" (32.4mm)	1.12" (28.5mm)

2. If necessary, adjust the nut on any spring that is unequal. Adjust all eight spring retaining nuts 1/3 of a turn (two flats on a nut) and check clutch slippage.
3. If further adjustment is necessary, adjust in 1/3 turn increments. Adjust only to provide sufficient torque to prevent slippage under normal conditions. Occasional slippage is normal for drivetrain protection. If satisfactory results cannot be obtained, consult your Blue Diamond authorized dealer.



DO NOT overtighten and cause the spring to become solid, as this will cause shaft failure.

Slip Clutch Disassembly / Assembly

If the clutch did not slip during the operational check, it will need to be disassembled to separate the clutch plates from the friction discs.

1. Measure and record the compressed (assembled) spring length. This dimension will be needed for reassembly.
2. Remove the spring retainer nuts (Item 1, below), springs (Item 2, below), and bolts (Item 3, below).

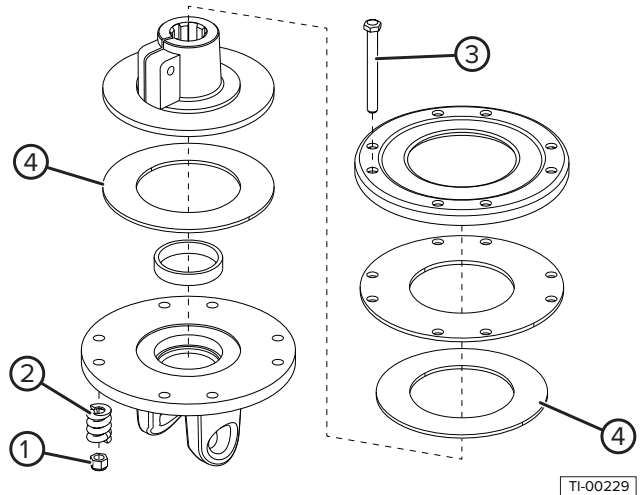

3. Separate each friction disc (Item 4, above) from the clutch plate next to it. **Keep the parts in order so that they can be reassembled in the same order.**
4. Clean and inspect all parts. If the clutch has been slipped to the point of "smoking", the friction discs should be replaced.
5. Reassemble each friction disc (Item 4, above) next to the same clutch plate it was removed from. Make certain all bushings are replaced in the same location they were removed from. Install bolts (Item 3, above) through the end plates as shown. Place springs (Item 2, above) over each bolt and secure with nuts (Item 1, above).
6. Tighten each nut until the original spring length is attained. If the original length was not recorded, use the spring length from the chart in section "Slip Clutch Adjustment" on page 39.

7. Service and Maintenance

7.6 Slip Clutch Maintenance Cont'd

Slip Clutch Run-In Procedure

If a clutch is being rebuilt (new facing and/or plates), it is necessary to “run-in” these parts prior to final adjustment. The plates should be thoroughly cleaned and free of foreign material, as well as being checked for warping with a straight edge. Warped plates cannot be adjusted properly and will not hold. To accomplish the “run-in” after assembly, follow this procedure:

1. Tighten all the adjusting bolts evenly until the clutch cannot be slipped by hand.
2. With the blade carrier locked in a stationary position, operate with the PTO at idling speed (approximately 100 RPM), until evidence of heating is noted. **Do not allow the clutch to overheat.**
3. Discontinue operation and **allow the clutch to cool completely.**
4. After the clutch has cooled, tighten all the adjusting bolts evenly and proceed with the regular clutch adjusting procedures.

7.7 Bolt Torque Requirements

It is extremely important to apply and maintain proper torque on all bolts. Use a torque wrench to ensure the proper amount of torque is being applied to the fastener.

Start all bolts or nuts by hand to prevent cross-threading.

Torque figures indicated in the chart are used for non-greased or non-oiled threads unless otherwise specified. Therefore, do not grease or oil bolts or cap screws unless otherwise specified in this manual.

When using locking elements, increase torque values by 5%.

The chart gives correct torque values for various bolts and cap screws. Tighten all bolts to the torque specified in the chart unless otherwise noted. Check tightness of bolts periodically, using the bolt torque chart found in section 9.2 Torque Specifications on page 66 as a guide. Always replace hardware with the same Grade bolt.



WARNING



EQUIPMENT FAILURE

The torque value for bolts and cap screws are identified by their head markings. Replacing higher “Grade” bolts (Grade 5) with lower Grade bolts will lead to equipment failure and can result in injury or death. Always use replacement bolts with the same Grade markings as the removed bolt.

7. Service and Maintenance

7.8 Service Record

The period recommended is based on normal operating conditions. Severe or unusual conditions may require more frequent service. Copy this page to continue record.

HOURS AND SERVICED BY:																				
MAINTENANCE																				
EVERY 8 HOURS																				
Make sure blade bolts are tightened to proper torque. Refer to "Blade Installation" on page 37.																				
Make sure all retainer clips and cotter pins are in place.																				
Inspect the cutting blades for wear and damage. Refer to "Blade Sharpening" on page 37.																				
Grease the driveline CV joint, U-joints, and slip joints. Refer to "Driveline Lubrication" on page 36.																				
EVERY 50 HOURS																				
Make sure blade carrier nut torque. Refer to "Blade Carrier" on page 38.																				
Grease all lubrication points. Refer to "Lubrication" on page 35.																				
ANNUALLY																				
Grease all lubrication points. Refer to "Lubrication" on page 35.																				
Make sure all fasteners are properly tightened.																				
Check cutter deck, gearboxes, and driveline for damage.																				
Inspect the cutting blades for wear and damage. Refer to "Blade Sharpening" on page 37.																				
Make sure the hitch pivot bolts and hitch pin are in good condition. Do not use homemade or shop made pins.																				
Make sure the slip clutches are functioning properly. Refer to "Slip Clutch Operational Check" on page 38.																				
Inspect the hitch and clevis for wear and damage.																				
Wash the rotary cutter																				

7. Service and Maintenance

7.9 Troubleshooting

PROBLEM	CAUSE	SOLUTION
Uneven cut.	Excessive ground speed.	Reduce ground speed.
	Blades worn, dull, or bent.	Replace blades.
	Improper height adjustment.	Adjust rotary cutter height. Refer to “Setting the Cutting Height” on page 23.
	Low tractor tire pressure on one side.	Adjust tire pressure. (Refer to OEM manual).
	Turning too fast.	Reduce ground speed when turning.
	Tractor tires pushing grass down.	Adjust your tractor wheel spacing. (Refer to OEM manual).
	Damaged cutter pan.	Repair or replace as necessary.
Uncut material	Excessive ground speed.	Reduce ground speed.
	RPM too low.	Maintain rated PTO RPM.
Windrowing.	Material heavy and lush.	Raise the front of the rotary cutter relative to the rear. Refer to “Setting the Rotary Cutter” on page 23.
	Excessive ground speed.	Reduce ground speed.
	Conditions too wet.	Wait for conditions to dry. Reduce ground speed.
Grass cut lower in center of swath than at the edge.	Height of rotary cutter lower at rear or front.	Adjust rotary cutter height and attitude so that rear and front are within 1/2” of same height.
Streaking conditions in swath.	Blades dull.	Sharpen or replace blades.
	Blades unable to cut that part of grass pressed by path of tractor tires.	Slow ground speed of tractor but maintain rated PTO RPM. Cutting lower will help.
	Conditions too wet for mowing.	Allow grass to dry before mowing.
Material discharges from cutter unevenly; bunches of material along swath.	Material too high and too much material.	Reduce ground speed but maintain rated tractor PTO RPM or make two passes over material.
		Raise rotary cutter for the first pass and lower to desired height for the second and cut at 90° to first pass.
		Raise rear of rotary cutter high enough to permit material to discharge but not so high as to cause conditions listed above.
	Grass wet.	Allow grass to dry before mowing. Reduce ground speed but maintain rated tractor PTO RPM.
Rotary cutter will not cut all the time.	Rear of rotary cutter too low, trapping material under cutter.	Adjust rotary cutter height and attitude.
	Slip clutch slipping.	Adjust slip clutch. Refer to “Slip Clutch Adjustment” on page 39.
Blade bolts working loose.	Burnt or damaged clutch facing.	Rework clutch or replace according to OEM manual.
	Bolts not tightened.	Tighten bolts. Refer to “Blade Maintenance” on page 36.
	Bolt hole elongated or oversized.	Replace blade carrier. Refer to “Blade Carrier Removal” on page 38.
Gearbox noisy.	Lockwasher broken.	Replace lockwasher. Refer to “Blade Maintenance” on page 36.
	Low lubricant level.	Add grease. Refer to “Gearbox Lubrication” on page 36.
Gearbox Overheating.	Worn bearing.	Replace bearing.
	Low on lubricant.	Fill to level plug.
	Improper type of lubricant.	Replace with proper lubricant. Refer to “Gearbox Lubrication” on page 36.
	Excessive trash build-up around gearbox.	Remove trash.

7. Service and Maintenance

7.9 Troubleshooting Cont'd

PROBLEM	CAUSE	SOLUTION
Gearbox leaking.	Damaged oil seal.	Replace seal.
	Bent shaft.	Replace gearbox.
	Oil seal not sealing in the housing.	Replace seal or use a sealant on O.D. of seal.
	Oil level too high.	Drain to proper level.
	Gasket damaged.	Replace gasket.
	Bolts loose.	Tighten bolts.
Excessive vibration.	Blades are not free to swing.	Check bushing and blade movement.
	Blades are out of balance.	Check blades for damage or replace blades. Refer to "Blade Servicing" on page 36.
Unusual noise.	Loose blade bolts or worn bushings.	Tighten bolts, check bushings for wear and change as needed. Refer to "Blade Servicing" on page 36.
	Bent blade carrier or blades.	Replace blade carrier or blades. Refer to "Blade Carrier Removal" on page 38.
	Deck bent, causing blades to contact deck.	Straighten deck.
Driveline will not telescope.	Improper lubrication.	Grease driveline. Refer to "Driveline Lubrication" on page 36.
	Driveline twisted.	Replace driveline. Caution operator not to strike ground with blades.
	Driveline bent.	Driveline too long. Replace and shorten to proper length. Refer to "Shortening the Driveline" on page 17.
	Shields damaged.	Replace shields.
Driveline U-Joint failing.	Lack of lubrication.	Grease U-Joint zerks every 8 hours. Refer to "Driveline Lubrication" on page 36.
Driveline twisted.	Over torqued.	Replace driveline. Caution operator not to strike ground with blades.
	Not maintaining correct PTO speed.	Maintain rated PTO RPM.
Slip clutches slip under light load.	Slip clutch is not properly adjusted.	Adjust slip clutch. Refer to "Slip Clutch Adjustment" on page 38.
	Clutch plates are worn out.	Replace clutch plates.
	Debris is caught between the clutch plates.	Remove debris.

8. Parts

8.1 A-Frame Components

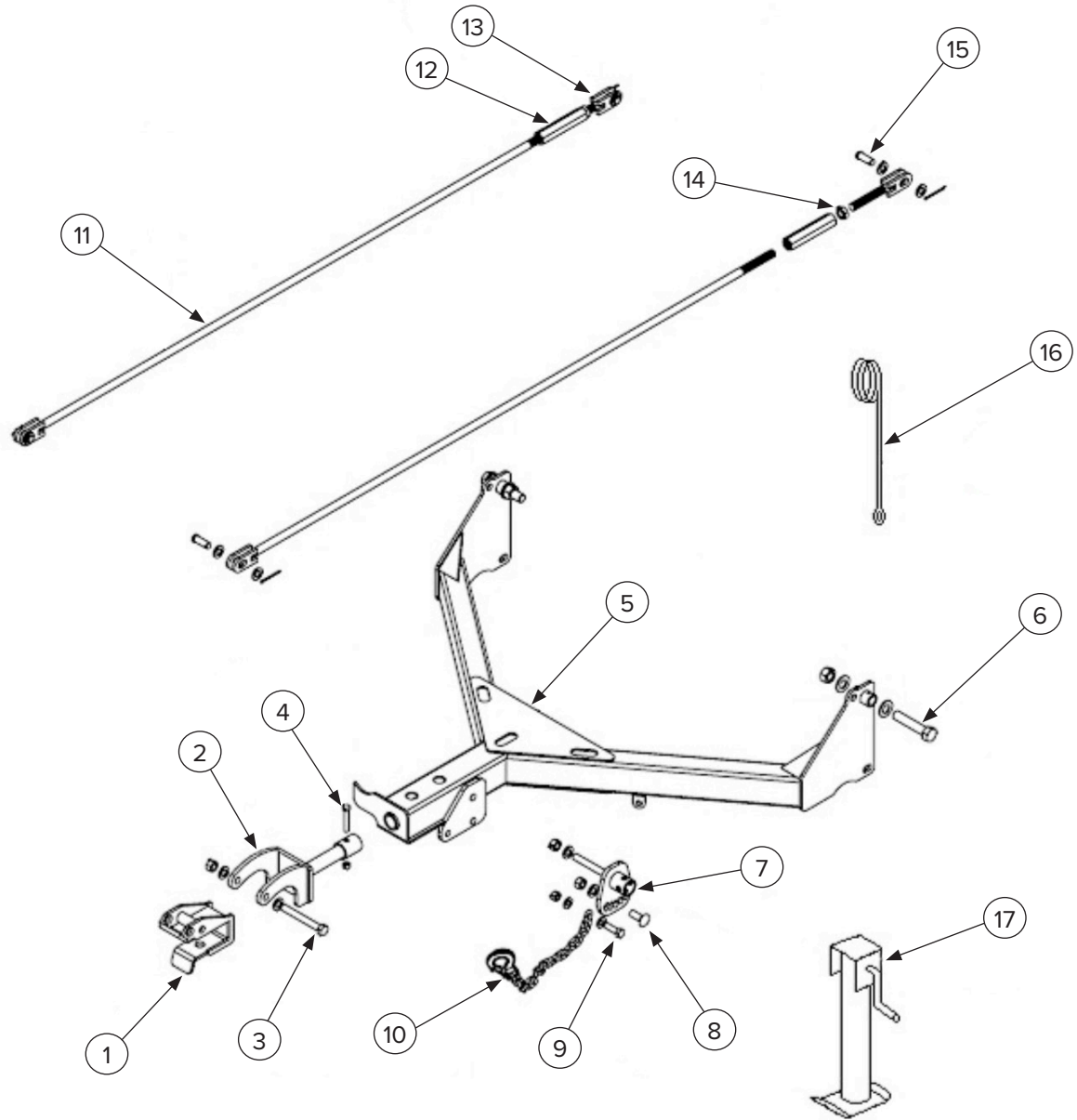

8. Parts

8.1 A-Frame Components Cont'd

ITEM	PART NUMBER	DESCRIPTION	QTY
1	502800	Clevis Hitch - Weldment	1
2	502801	Receiving Hitch - Weldment	1
NS	503770	Swivel Lock Collar	1
3	503606	Bolt Kit 3/4" x 6" W/Flat Washer & Locknut	1
4	503620	Swivel Bolt Kit 1/2" x 2-1/2" W/Locknut	1
5	503771	A-Frame Hitch - Weldment	1
6	502878	Bolt Kit 1" x 4-1/2" W/Flat Washers & Locknut	2
7	502805	Jack Lug - Weldment	1
8	503605	Carriage Bolt Kit 1/2" x 1-1/2" W/Locknut	1
9	503772	Bolt Kit 5/8" x 2-1/2" Bolt with Locknut & Washers	1
10	503689	Safety Chain	1
11	502809	Long Leveling Rd 85"	2
12	503635	Leveling Rod Adjuster	2
13	503040	Short Leveling Rod 7-5/8"	2
14	502810	Jam Nut 7/8"	2
15	502811	Clevis Pin w/Flat Washers & Cotter Pin	4
16	503617	Spring - Hose Holder	1
17	503640	Jack Stand	1

8. Parts

8.2 Center Deck Components

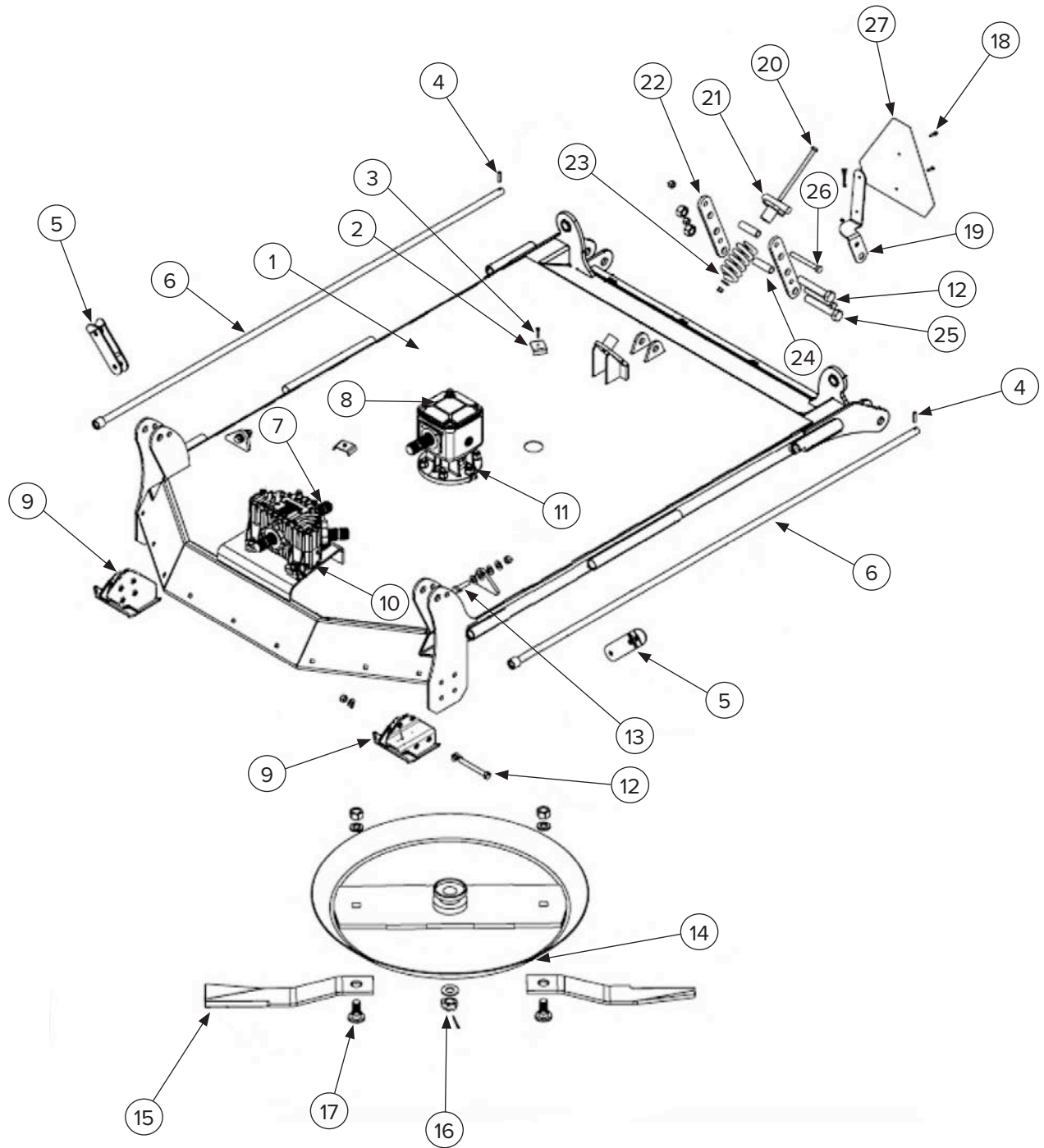

8. Parts

8.2 Center Deck Components Cont'd

ITEM	PART NUMBER	DESCRIPTION	QTY
1	503773	Center Deck - Weldment (Specify Color)	1
2	503774	Hose Holder	2
3	502814	Self-Tapping Screw 1/4" x 1-1/2"	2
4	502815	Roll Pin 3/8" x 1-3/4"	2
5	502816	Deck Lock - Welment	2
6	503775	Hinge Rod 1" x 62-3/4"	2
7	503688	Splitter Gear Box - 540 RPM	1
8	503776	Center Gear Box - 540 RPM	1
9	503777	LH - Front Center Skid Shoe	1
	503778	RH - Front Center Skid Shoe	1
10	502822	Bolt Kit (4-Pack) 5/8" x 2" bolts W/Locknuts	1
411	502861	Bolt Kit (6-Pack) 3/4" x 2-1/2" Bolts W/Locknuts	1
12	502825	Bolt Kit 5/8" x 2-1/2" Bolt W/Locknut	8
13	502825	Bolt Kit 5/8" x 2-1/2" Bolt W/Locknut	2
14	503779	Blade Carrier	1
15	503779	Blade Carrier	1
16	503677	Castle Nut M24 x 2	1
	503676	Flat Washer 25 x 44 x 4	1
	503678	Cotter Pin 5 x 50	1
17	503202	Blade Bolt Kit (Sold as Pair) W/Nuts & Lock Washers	1
18	502829	Bolt Kit 1/4" x 1" Bolt W/Locknut	2
19	502830	SMV Sign Bracket	1
20	503625	Spring Bolt Kit 1/2" x 9 Bolt W/Washer & Locknut	1
21	502831	Spring Mount Bracket	1
22	502832	Suspension Spring Bracket	2
23	503624	Suspension Spring .625 x 3.2" O.D. x 6"	1
24	503629	Bracket Bolt Spacer 3.5"	2
25	503630	Spring Arm Bolt Kit 1" x 6" Bolt W/Lock Nut	2
26	503628	Spring Brkt. Bolt Kit 5/8" x 5-1/2" Bolt W/FW & LN	1
27	502833	SMV Kit	1

8. Parts

8.3 Center Shield Components

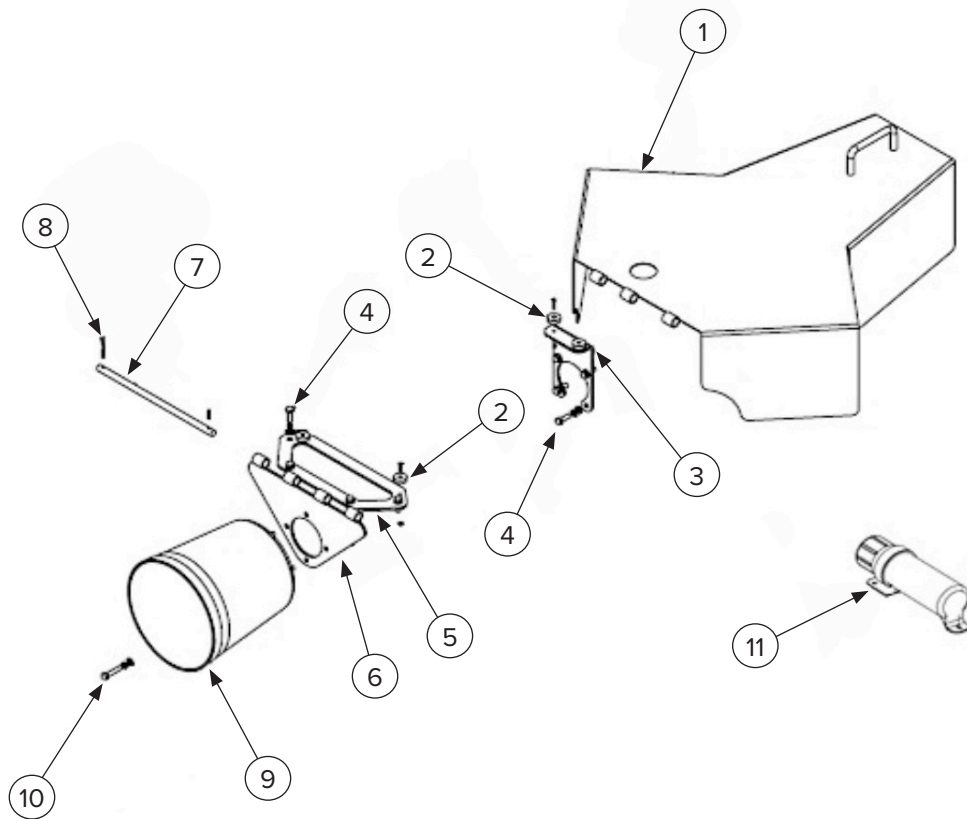

ITEM	PART NUMBER	DESCRIPTION	QTY
1	503780	Splitter Gearbox Shield	1
2	502835	Magnet Kit 6-32 x 3/4" CSK Bolt & Locknut	4
3	503781	Center-Gear Box Magnet Mount	1
4	502837	Bolt Kit (8-Pack) M8 x 25 Bolts W/FW & Nuts	1
5	502838	Splitter-Gear Box Magnet Mount	1
6	502839	Center Shield Mount	1
7	502840	Center Shield Hinge	1
8	502841	Roll Pin 3/16" x 3/4"	2
9	503604	Gearbox Shield (Plastic)	1
10	502842	Bolt Kit (4-Pack) M8 x 40 Bolts W/LW & FW	1
11	503601	Manual Holder	1

8. Parts

8.4 Driveline & Shield Components

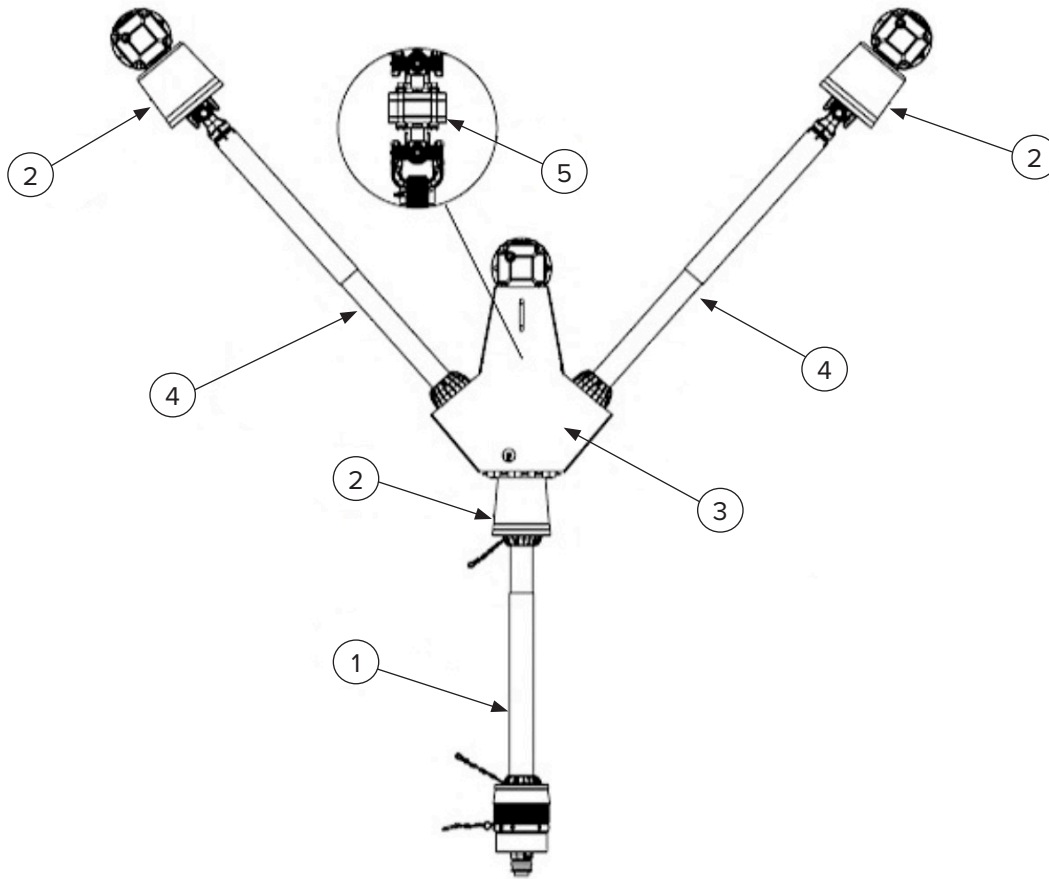

ITEM	PART NUMBER	DESCRIPTION	QTY
1	503520	C.V. PTO Driveline S6CVE-1321	1
2	503604	Gearbox Shield (Plastic)	1
3	503780	Splitter Gearbox Shield	1
4	503653	Wing PTO Driveline S507CLE-1316	2
5	503614	Cross Shaft S4ECL - 366	1

8. Parts

8.5 Wing Deck Components

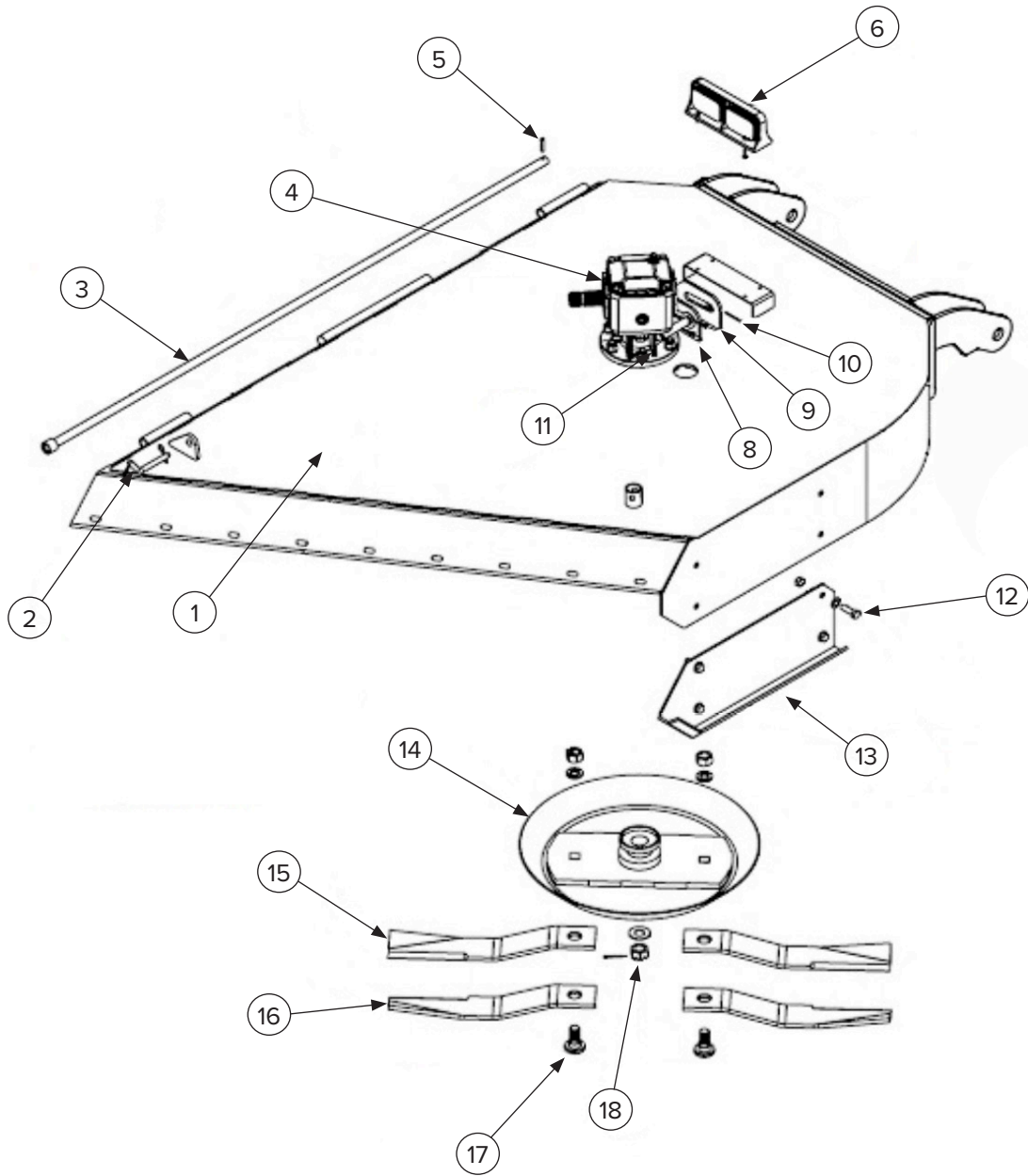

8. Parts

8.5 Wing Deck Components Cont'd

ITEM	PART NUMBER	DESCRIPTION	QTY
1	503782	LH Wing Deck - Weldment (specify color)	—
NS	503783	RH Wing Deck - Weldment (specify color)	—
2	502851	Bent Pin 5/8" W/R-Clip	1
3	503775	Hinge Rod 1" x 62-3/4"	1
4	503776	LH Gear Box 540-RPM	—
NS	503784	RH Gear Box 540-RPM	—
5	502815	Roll Pin 3/8" x 1-3/4"	2
6	502856	Caution Light Kit	1
7	502857	Bolt Kit 1/4" x 1" Bolt W/Locknut	4
8	502858	Clevis Pin 1"	1
9	502859	Flat Washer 1" SAE	2
10	502860	Cotter Pin 1/8" x 2	2
11	502861	Bolt Kit (6-Pack) 3/4" x 2-1/2" Bolts W/Locknuts	1
12	502822	Bolt Kit (4-Pack) 5/8" x 2" bolts W/Locknuts	1
13	502863	LH Wing Skid Shoe	—
NS	502864	RH Wing Skid Shoe	—
14	503779	Blade Carrier	1
15	503764	RH - CCW Blade (Sold as Pairs)	1
16	503763	LH - CW Blade (Sold as Pairs)	1
17	503202	Blade Bolt Kit (Sold as Pair) W/Nuts & Lock Washers	1
18	503677	Castle Nut M24 x 2	1
NS	503676	Flat Washer 25 x 44 x 4	1
NS	503678	Cotter Pin 5 x 50	1

8. Parts

8.6 Wheel Lift Components

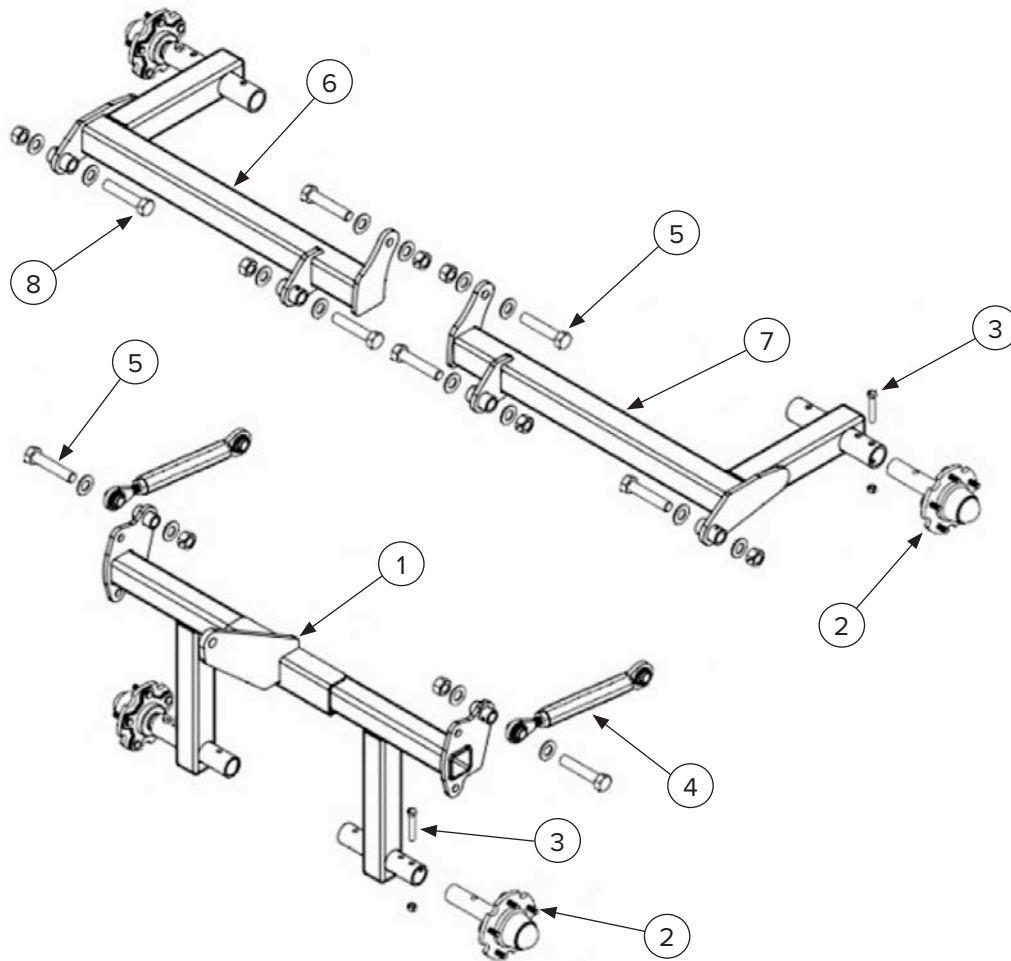

ITEM	PART NUMBER	DESCRIPTION	QTY
1	503785	Center Wheel Lift - Weldment	1
2	503608	Hub/Spindle Assembly	6
3	503609	Spindle Bolt Kit 1/2" x 3-1/2" Bolt W/Locknut	6
4	503755	Turnbuckle	2
5	503772	Bolt Kit 5/8" x 2-1/2" Bolt with Locknut & Washers	4
6	503786	RH Wing Wheel Lift - Weldment	1
7	503787	LH Wing Wheel Lift - Weldment	1
8	502878	Bolt Kit 1" x 4-1/2" W/Flat Washers & Locknut	6

8. Parts

8.7 Wheel Options

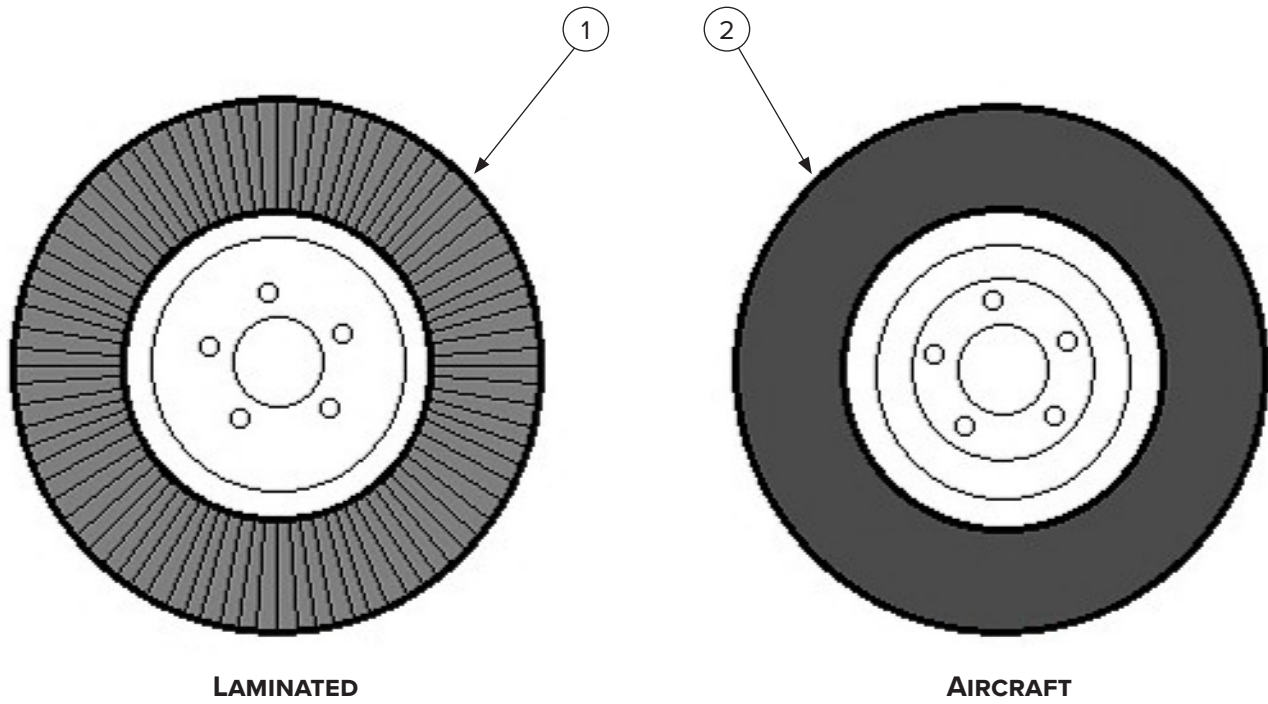

ITEM	PART NUMBER	DESCRIPTION	QTY
1	503610	Laminated Wheel 20"	—
2	503686	Aircraft Tire 22" (Foam Filled)	—

8. Parts

8.8 Hydraulic Components

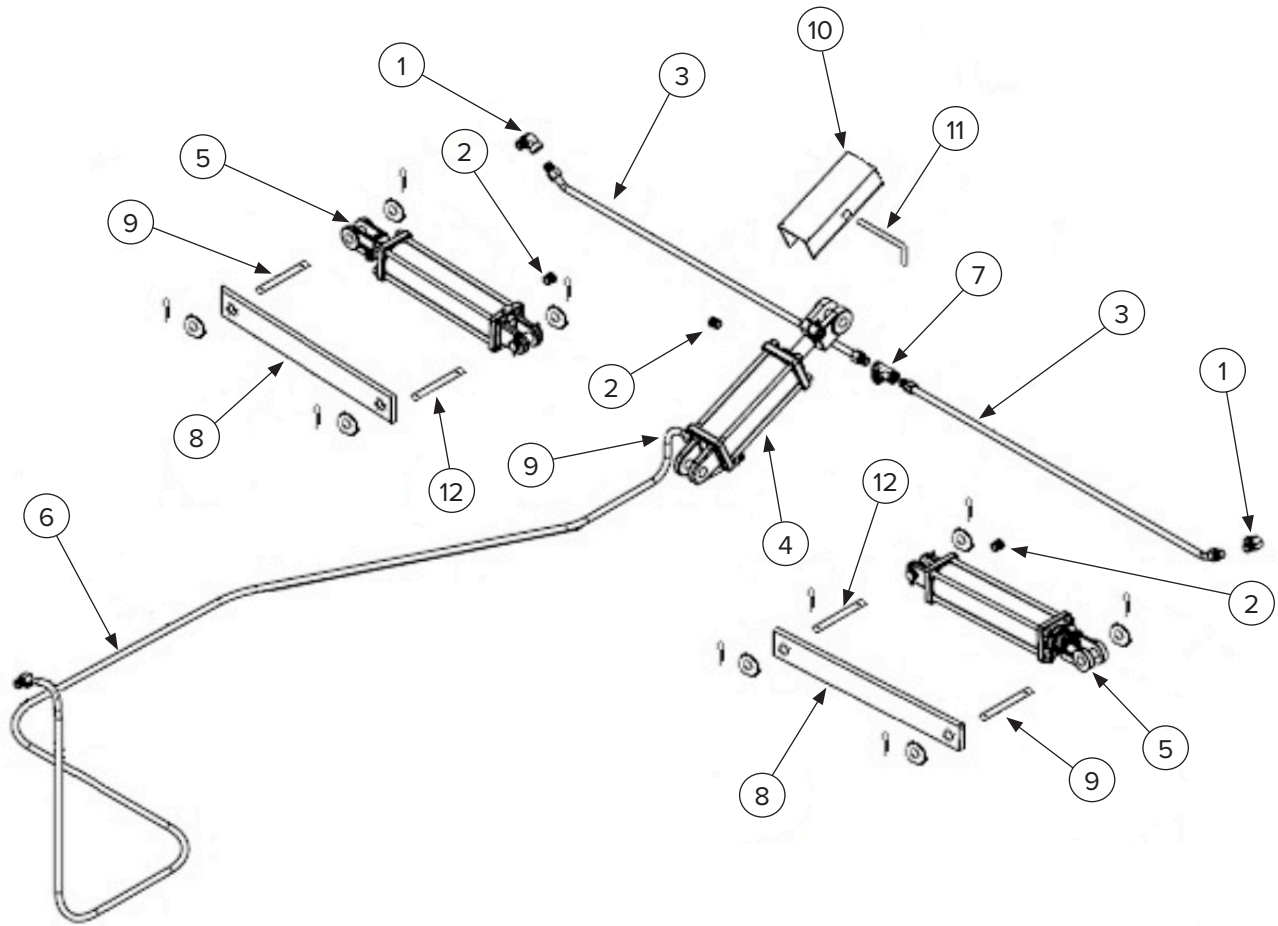

ITEM	PART NUMBER	DESCRIPTION	QTY
1	295030-M06JIC-M08NPT	Elbow 8MP-6MJ	—
OR	295030-M06JIC-M06NPT	ELBOW 6-MJ-6MP90	—
2	502884	Breather 8-NPTM	1
3	503641	Hyd. Hose 1/4" x 57"	2
4	503631	Center-Transport Cylinder	1
5	503632	ASAE Cylinder 2" x 8"	2
6	503642	Hyd.Hose 1/4" x 144	1
7	503643	Tee Fitting 8-NPTF	1
8	503633	Wing Lock Bar	2
9	503645	Outside Cyl. Pin 1" x 5-1/2"	2
10	503691	Cyl. Transport Lock	1
11	503530	L-Shaped Pin 1/2"	1
12	503692	Inside Wing Cyl. Pin 1" x 5"	2

8. Parts

8.9 Chain Guards Components

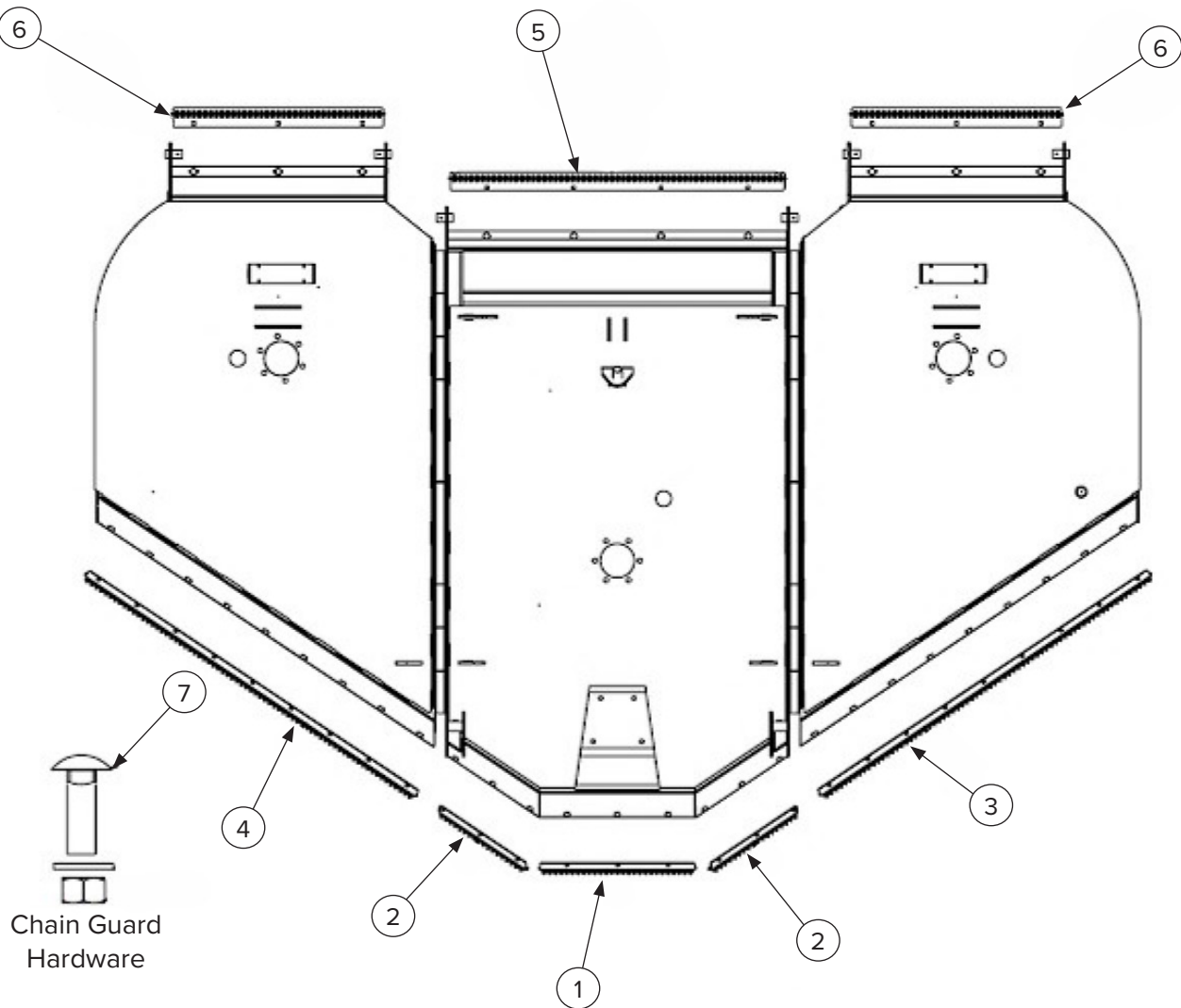

ITEM	PART NUMBER	DESCRIPTION	QTY
1	503757	Center Deck Front Chain Shield Assy	1
2	503758	Center Deck Front RH & LH Chain Shield Assy	2
3	503759	LH Wing Deck Chain Shield Assy	1
4	503760	RH Wing deck Chain Shield Assy	1
5	503761	Center Deck Rear Chain Shield Assy	1
6	503762	LH & RH Rear Wing Deck Chain Shield Assy	2
7	503652	Carriage Bolt Kit 1/2" x 1-1/2" (10 Pack)	—
NS	503756	Complete Shield Kit	—

8. Parts

8.10 Driveline & Shield Components

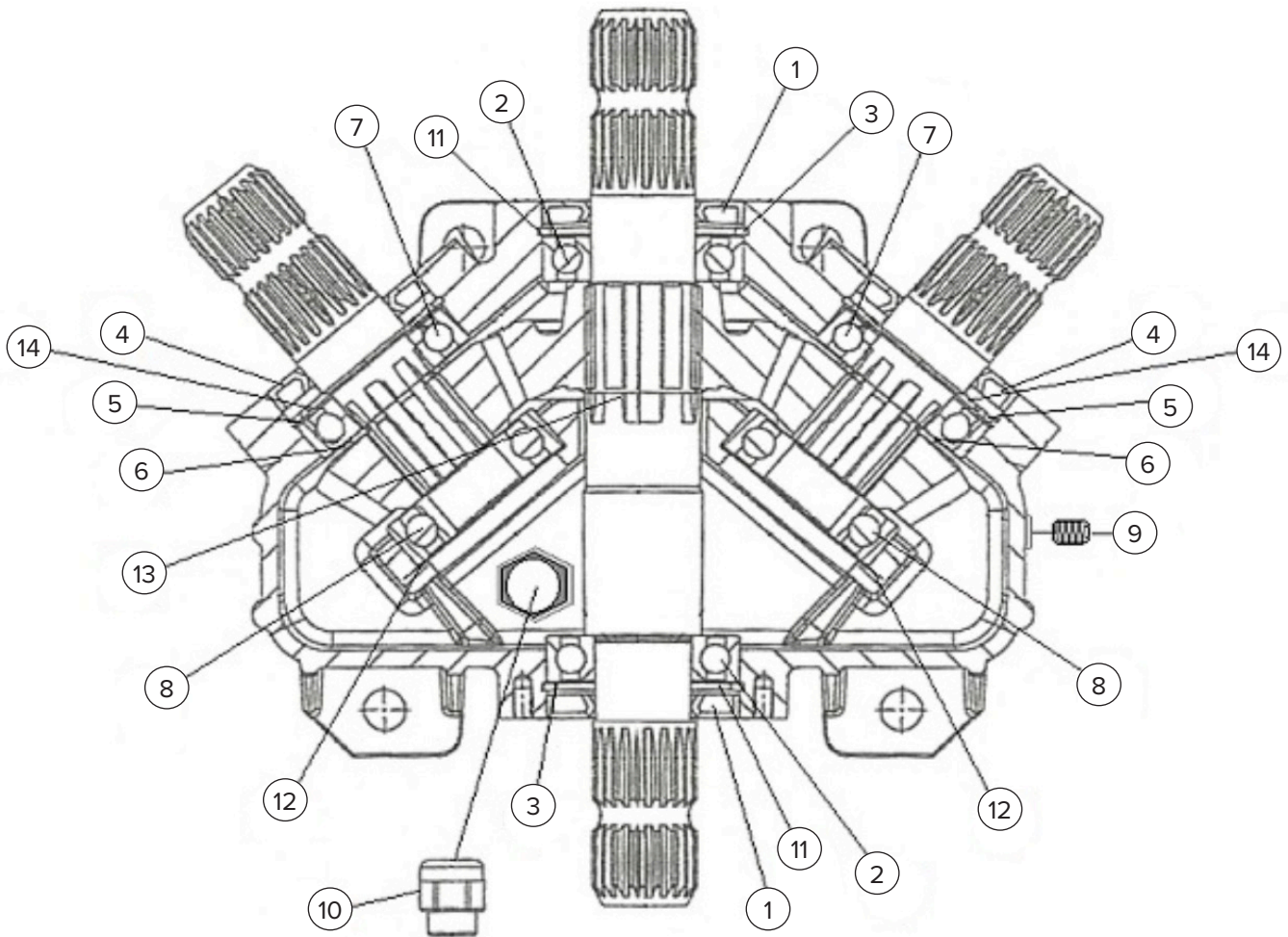

140 (ISO460)
Gearoil Recommended

Fill level 61-oz. (1.83-qt)

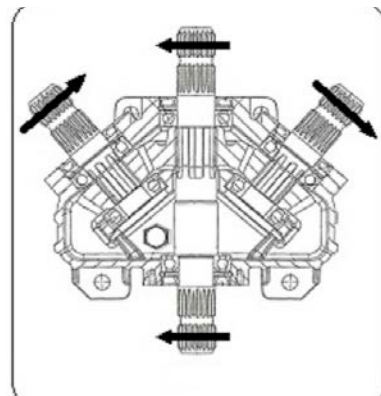

8. Parts

8.10 Driveline & Shield Components Cont'd

ITEM	PART NUMBER	DESCRIPTION	QTY
1	503694	Input Oil Seal 45 x 85 x 10	2
2	503695	Input Bearing 6209 - for Thru Shaft	2
3	503696	Snap Ring 85 x 88.5 x 3	2
4	503697	Output Seal 45 x 80 x 10	2
5	503698	Snap Ring 80 x 83.5 x 2.5	2
6	503699	Snap Ring 40 x 37.5 x 2.5	2
7	503700	Bearing 6208	2
8	503701	Bearing 6307	2
9	503702	Check Plug 3/8"	2
10	503703	Breather Plug 1/2"	1
11	503704	Shim Kit 70.3 x 84.7	2
12	503705	Shim Kit 69.0 x 79.9	2
13	503707	Snap Ring 47 x 45.5 x 1.5	1
14	503706	Shim Kit 65.3 x 79.7	2

8. Parts

8.11 Center Deck Driveline Components

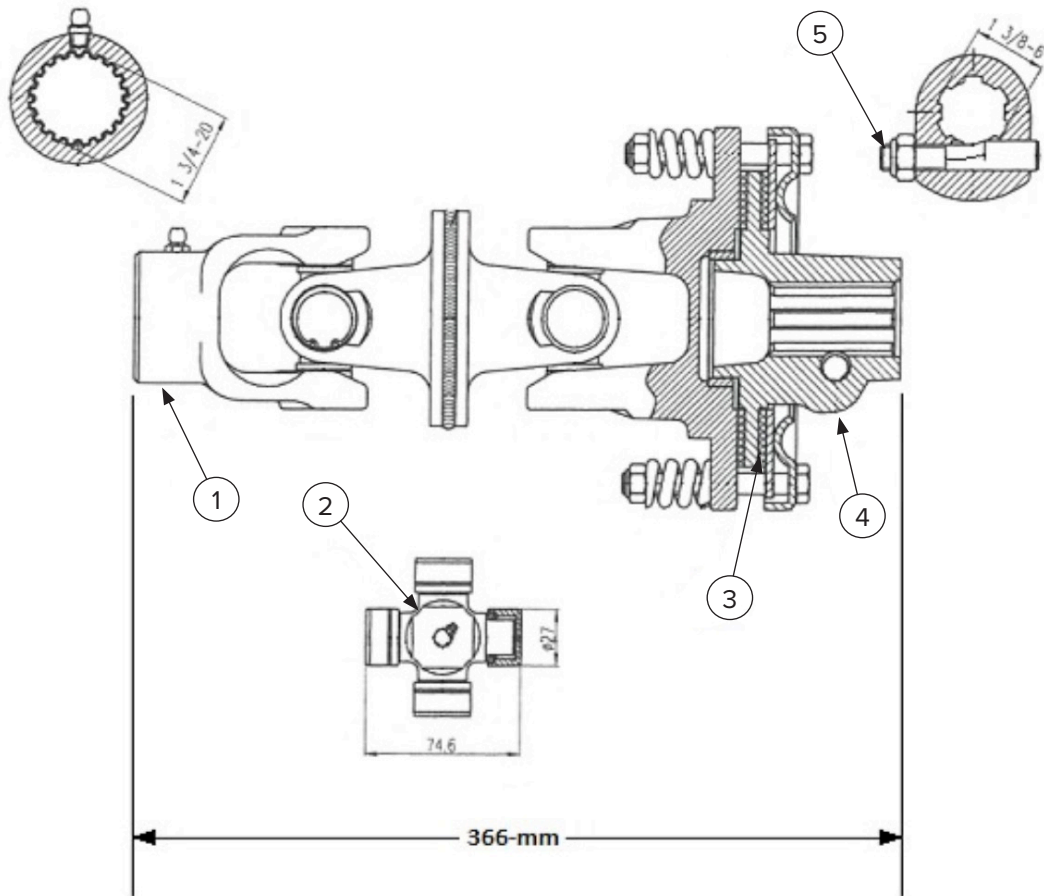

ITEM	PART NUMBER	DESCRIPTION	QTY
1	503731	Gearbox Yoke 1-3/4" 20-Spline	1
2	503732	Cross Kit 27 x 74.6	2
3	503733	Clutch Lining (2-Pack)	1
4	503734	Complete Slipclutch	1
5	503735	Eccentric Pin with Nut	1

8. Parts

8.12 C.V. Drive Components

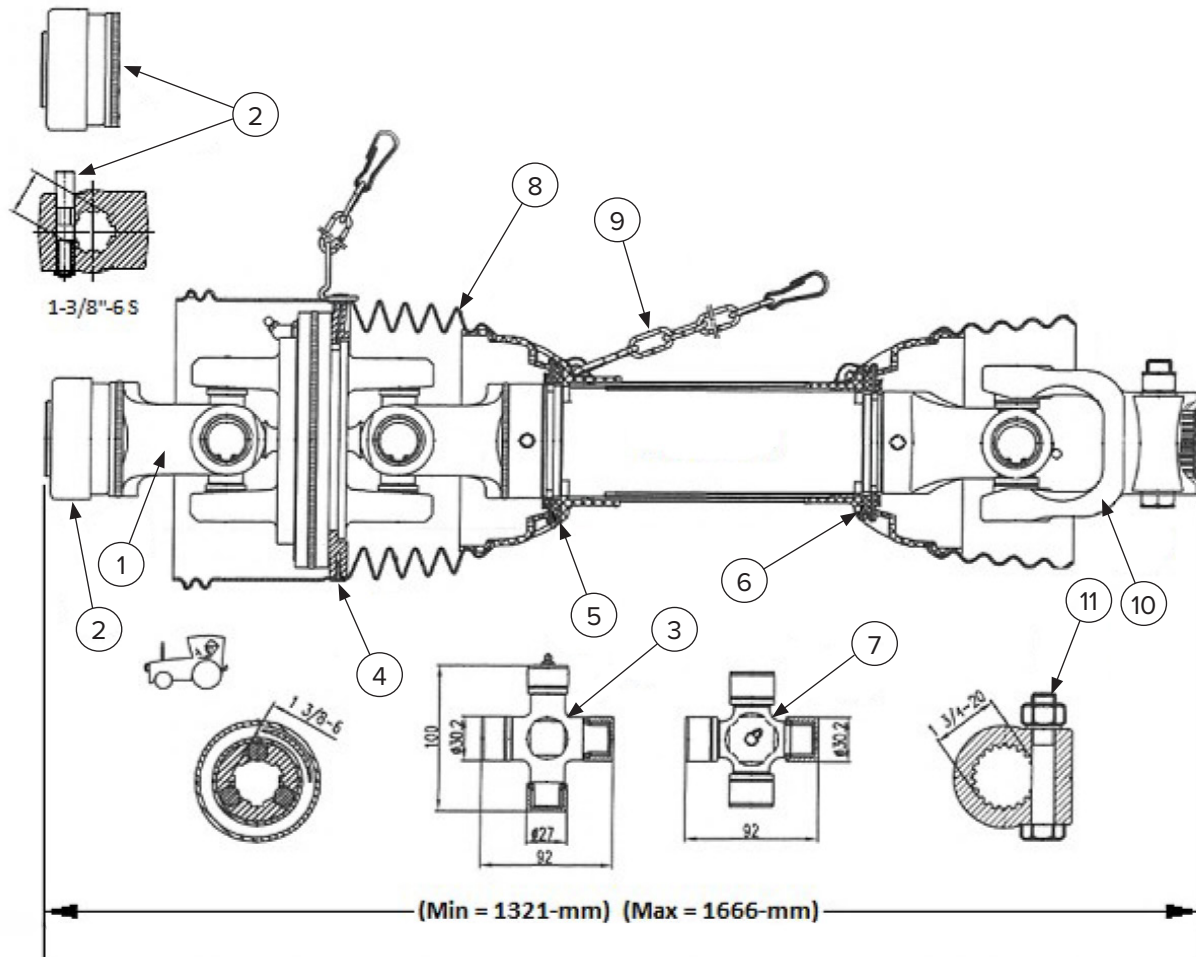

ITEM	PART NUMBER	DESCRIPTION	QTY
1	503745	Tractor Yoke with Pull Collar - 1-3/8" 6-Spline	1
2	503746	Pull Collar for Yoke	—
NS	503788	Push Pin Kit	—
3	503747	Cross Kit 27 / 30.2 x 100	2
4	503748	Fixed Ring for C.V. Shield	1
5	503749	Outer Plastic Shield Bearing	1
6	503750	Inner Plastic Shield Bearing	1
7	503751	Cross Kit 30.2 x 92	1
8	503752	Complete Safety Shield	1
9	503730	Safety Chain	3
10	503753	Yoke 1-3/4" 20-Spline	1
11	503754	Lock Bolt with Nut	1

8. Parts

8.13 Wing Driveline Components

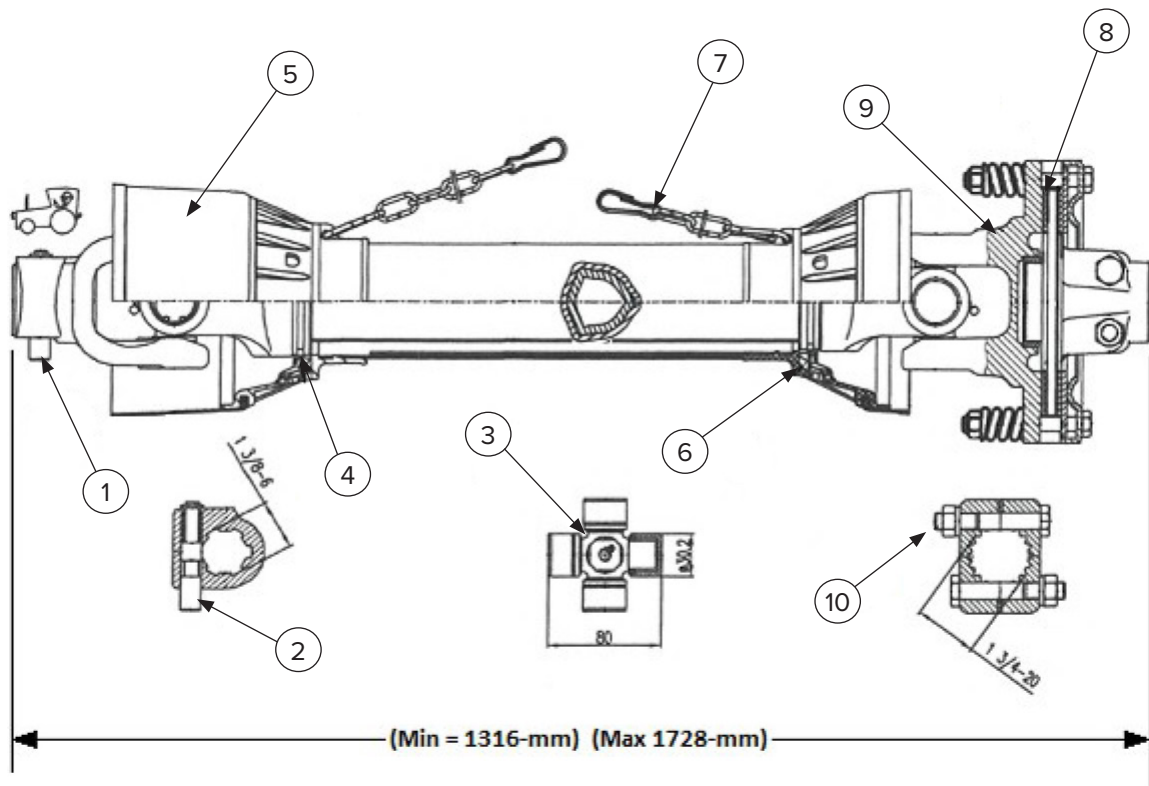

ITEM	PART NUMBER	DESCRIPTION	QTY
1	503736	Tractor Yoke 1-3/8" with Push Pin	1
2	503737	Push Pin Kit	1
3	503738	Cross Kit 30.2 x 80	2
4	503739	Outer Plastic Shield Bearing	1
5	503740	Complete Safety Shield	1
6	503741	Inner Plastic Shield Bearing	1
7	503730	Safety Chain	2
8	503742	Clutch Lining (2-Pack)	1
9	503743	Complete Slipclutch	1
10	503744	Lock Bolt with Nut	1

8. Parts

8.14 Safety Decal Locations

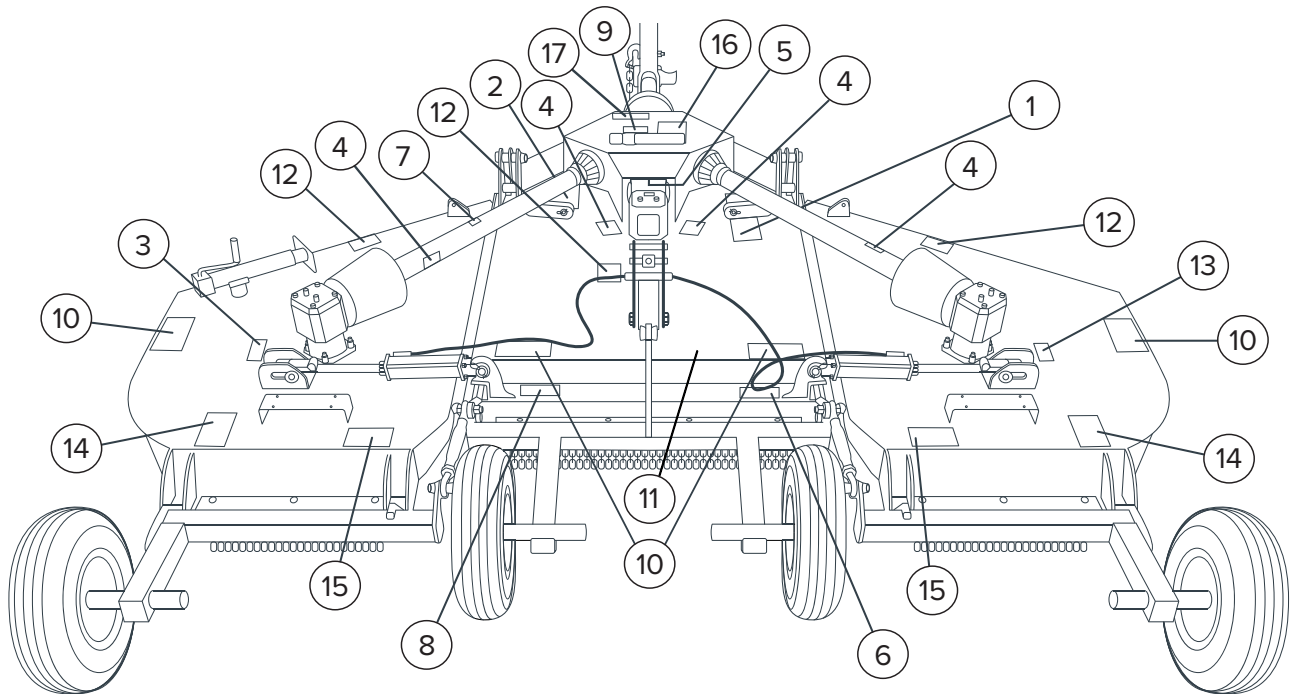

ITEM	TYPE	DESCRIPTION	QTY
1	DANGER	Follow Safety Messages	1
2	DANGER	Maintain Shields and Deflectors	1
3	INSTRUCTIONAL	Blade Rotation (CCW)	1
4	DANGER	Rotating Driveline, Keep Away, Outer Shield Tube	2
5	DANGER	Shield Missing, Do Not Operate	1
6	WARNING	Use Paper or Cardboard to Check for Leaks	1
7	WARNING	PTO Speed 540 RPM	1
8	DANGER	Read the Manual (Spanish)	1
9	WARNING	Keep Mower Deck Clear of Debris	1
10	WARNING	No Riders	4
11	SERIAL	Serial Number	1
12	INSTRUCTIONAL	Made in the USA	3
13	INSTRUCTIONAL	Blade Rotation (CW)	1
14	DANGER	Keep Away - Thrown Objects	2
15	DANGER	Stay Clear	2
16	WARNING	Do Not Transport at Speeds Over 20 MPH	1
17	INSTRUCTIONAL	5 Year Gearbox Limited Warranty	1

8. Parts

8.15 Safety Decal Locations Cont'd

1 **DANGER**

1. Make certain drivelines are of the correct length and securely attached. DRIVELINE SEPARATION and/or PTO SHAFT FAILURE can cause INJURY or DEATH. (See Operator's Manual for procedure.)

2. Make certain that driveline shields are **INSTALLED CORRECTLY** and **TURN FREELY** to prevent injury or death from entanglement.

3. Make certain that driveline is installed correctly on TRACTOR PTO SHAFT. Move yoke back and forth until locking collar clicks forward and locks yoke in place.

4. **516 PTO RPM** unless specifically marked otherwise.

2 **DANGER**

FAILING TO FOLLOW SAFETY MESSAGES AND OPERATING INSTRUCTIONS CAN CAUSE SERIOUS BODILY INJURY OR EVEN DEATH TO OPERATOR AND OTHERS IN THE AREA.

1. READ MANUAL

2. NO CHILDREN OPERATORS

3. WEAR SAFETY BELT, SEATBELT, & ROPS

4. CHECK UP SAFETY BEFORE WORKING - STOPPING

5. STAY CLEAR WHEN REMOVING TRANSPORT STRAP AND SWINGING OR ROTATING WING.

6. COMPONENT FAILURE OR ACCIDENTAL OPERATION OF CONTROLS MAY ALLOW WING TO FALL SUDDENLY AND CAUSE BODILY INJURY OR DEATH.

7. CYLINDERS WITH @ RESTRICTIONS INSTALLED MUST BE Filled with oil for wings to lower slowly and safely.

8. LOCK WINGS UP SECURELY FOR TRANSPORTING.

9. DO NOT OPERATE MOWER WITH WINGS RAISED WHEN PASSESABY ARE IN THE AREA.

10. CONTACT WITH EXPOSED ROTATING BLADES AND/OR BEING HIT BY THROWN OBJECTS MAY CAUSE INJURY OR DEATH.

3 **BLADE ROTATION**

4 **DANGER**

ROTATING DRIVELINE CONTACT CAN CAUSE DEATH

KEEP AWAY!

DO NOT OPERATE WITHOUT

- All driveline guards, tractor and equipment shields in place
- Drivelines securely attached at both ends.
- Driveline guards that turn freely on driveline

5 **DANGER**

SHIELD MISSING

DO NOT OPERATE

DANGER

6 **WARNING**

Use paper or cardboard to check for leaks. NEVER USE YOUR HAND. If oil penetrates skin, gangrene or other serious injury could occur. **GET IMMEDIATE MEDICAL ATTENTION.** See Operator's manual.

7 **WARNING**

OPERATE THIS MACHINE AT **540 RPM** TRACTOR PTO SPEED ONLY

Overspeeding PTO may cause component failure with resulting injury.

8 **PELIGRO**

Si No Lee Ingles, Pida Ayuda a Alguien Que si Lo Lea Para Que le Traduzca las Medidas de Seguridad.

LEA EL INSTRUCTIVO

READ MANUAL

9 **WARNING**

Keep Mower Deck Clear of Debris

There is a risk of Fire when dry material accumulates and contacts heat generated from rotating components. See Operator's Manual for fire prevention.

10 **WARNING**

NO RIDERS

12 **MADE IN THE USA**

WITH U.S.-&IMPORTED PARTS

13 **BLADE ROTATION**

14 **DANGER**

KEEP AWAY - THROWN OBJECTS

Inspect the area before mowing for potential mower hazards. Remove or avoid all foreign objects such as wire, cable, metal objects, and all other foreign material.

Foreign material can be thrown from the mower and cause serious bodily injury to the operator and passerby.

Do Not let rotating blades contact solid objects like rocks, posts, curbs or guard rails.

Operate only if all Guards-Deflectors are in place and in good condition.

Do not operate with Mower or Wing raised off the ground.

Stop mowing if Passerby enter the area of thrown objects. (See Operator's Manual)

Stay away from rotating blades. Keep hands and feet away from rotating blades.

Do Not approach mower until all motion has stopped.

15 **DANGER**

Stay clear when removing transport strap and swinging or rotating wing.

Component failure or accidental operation of controls may allow wing to fall suddenly and cause BODILY INJURY OR DEATH.

Cylinders with @ RESTRICTIONS INSTALLED must be Filled with oil for wings to lower slowly and safely.

Lock wings up securely for transporting.

Do not operate mower with wings raised when passerby are in the area.

Contact with Exposed Rotating Blades and/or being hit by thrown objects may cause INJURY OR DEATH.

16 **NOTICE TO OWNER**

An OPERATOR'S MANUAL (with Required Parts Listing) and a WARRANTY REGISTRATION CARD were attached to this implement during final inspection at the factory. If they were not attached at the time of purchase, please contact your dealer at once.

- Read and understand Manual before operating the implement.
- Complete, sign, and mail the Warranty Registration Card in today.

IMPORTANT

REQUIRED FOR JACK SHAFT UNIT SUGGESTED FOR STANDARD SHAFT

1" (25.4MM) 1/2" (12.7MM) 3/4" (19.0MM) 1" (25.4MM) 1 1/4" (31.8MM) 1 3/4" (44.5MM) 2" (50.8MM)

14" (355.6MM) 16" (406.4MM) 20" (508.0MM) 24" (609.6MM) 30" (762.0MM)

Attach Safety Chain securely as per ANSIS S3.55

WARNING

- DO NOT transport at speeds above 20 mph. Exceeding 20 mph decreases braking ability and may cause loss of control and serious personal injury.
- ONLY transport behind a properly sized and equipped tractor. NEVER tow behind a truck or other motor vehicle. ALWAYS properly fasten the implement safety tow chain to the tractor.
- Reduce speed on inclines, while turning, and when towing in adverse conditions.
- ENSURE a 50MPS emblem can be clearly seen from behind the sign. Turn ON the tractor flashing warning lights when transporting.

17 **5 YEAR GEARBOX LIMITED WARRANTY**

(Signs portrayed for reference, not to scale)

9. Specifications

9.1 Attachment Specifications

DESCRIPTION	12' FLEX WING ROTARY BRUSH CUTTER
Recommended Minimum HP	35 HP (Gear Drive Transmission)
Hitch	Swivel Clevis
Deck Thickness	10 Gauge
Deck Height	11"
Side Skirt Material	3/16"
Hinge Rods	1"
Outboard Gearbox	75 HP
Splitter Gearbox	175 HP
Input PTO	ASAE CAT 5 Constant Velocity
Wing Drive PTO	ASAE CAT 4 with Slip Clutch
Gearbox RPM	540 RPM
Blades	1/2" X 3" with Lift
Blade Tip Speed	15,657 FPM
Blade Overlap	6"
Blade Carrier	3/16" Formed Plate with 3/4" X 6" Bar
Cut Width	144"
Overall Width	151"
Overall Length with Wheels	158"
Tongue Weight	759 lb.
Overall Weight	2630 lb
Cut Height	1-1/2"-12"
Cutting Capacity	Up to 2"
Wheel Type	5 Lug Laminated Std Used Airplane Optional
Suspension (Shock Absorber)	Single Spring
Skid Shoes	Replaceable
Chain Shields	Single Row Chain Shields Standard
Towing Safety Chain	Standard
Gearbox Warranty	5 Year Limited

9. Specifications

9.2 Torque Specifications

Standard Hardware and Lock Nuts

BOLT TYPE	SAE GRADE 5		SAE GRADE 8		LOCK NUTS			
	Nominal Size	Plated or Unplated Silver	Plated W/ ZnCr Gold	Plated or Unplated Silver	Plated W/ ZnCr Gold	Plated or Unplated Silver	Plated W/ ZnCr Gold	W/ Grade 5 Bolt
1/4	55 in / lb (6.2 N•m)	72 in / lb (8.1 N•m)	86 in / lb (9.7 N•m)	112 in / lb (12.6 N•m)	121 in / lb (13.6 N•m)	157 in / lb (17.7 N•m)	61 in / lb (6.9 N•m)	86 in / lb (9.8 N•m)
5/16	115 in / lb (13 N•m)	149 in / lb (17 N•m)	178 in / lb (20 N•m)	229 in / lb (26 N•m)	250 in / lb (28 N•m)	325 in / lb (37 N•m)	125 in / lb (14 N•m)	176 in / lb (20 N•m)
3/8	17 ft / lb (23 N•m)	22 ft / lb (30 N•m)	26 ft / lb (35 N•m)	34 ft / lb (46 N•m)	37 ft / lb (50 N•m)	48 ft / lb (65 N•m)	19 ft / lb (26 N•m)	26 ft / lb (35 N•m)
7/16	27 ft / lb (37 N•m)	35 ft / lb (47 N•m)	42 ft / lb (57 N•m)	54 ft / lb (73 N•m)	59 ft / lb (80 N•m)	77 ft / lb (104 N•m)	30 ft / lb (41 N•m)	42 ft / lb (57 N•m)
1/2	42 ft / lb (57 N•m)	54 ft / lb (73 N•m)	64 ft / lb (87 N•m)	83 ft / lb (113 N•m)	91 ft / lb (123 N•m)	117 ft / lb (159 N•m)	45 ft / lb (61 N•m)	64 ft / lb (88 N•m)
9/16	60 ft / lb (81 N•m)	77 ft / lb (104 N•m)	92 ft / lb (125 N•m)	120 ft / lb (163 N•m)	130 ft / lb (176 N•m)	169 ft / lb (229 N•m)	65 ft / lb (88 N•m)	92 ft / lb (125 N•m)
5/8	83 ft / lb (112 N•m)	107 ft / lb (145 N•m)	128 ft / lb (174 N•m)	165 ft / lb (224 N•m)	180 ft / lb (244 N•m)	233 ft / lb (316 N•m)	90 ft / lb (122 N•m)	127 ft / lb (172 N•m)
3/4	146 ft / lb (198 N•m)	189 ft / lb (256 N•m)	226 ft / lb (306 N•m)	293 ft / lb (397 N•m)	319 ft / lb (432 N•m)	413 ft / lb (560 N•m)	160 ft / lb (217 N•m)	226 ft / lb (306 N•m)
7/8	142 ft / lb (193 N•m)	183 ft / lb (248 N•m)	365 ft / lb (495 N•m)	473 ft / lb (641 N•m)	515 ft / lb (698 N•m)	667 ft / lb (904 N•m)	258 ft / lb (350 N•m)	364 ft / lb (494 N•m)
1	213 ft / lb (289 N•m)	275 ft / lb (373 N•m)	547 ft / lb (742 N•m)	708 ft / lb (960 N•m)	773 ft / lb (1048 N•m)	1000 ft / lb (1356 N•m)	386 ft / lb (523 N•m)	545 ft / lb (739 N•m)



Warranty

MANUFACTURER'S LIMITED WARRANTY

BLUE DIAMOND® ATTACHMENTS, a manufacturer of quality attachments, warrants new BLUE DIAMOND® ATTACHMENTS products and/or attachments at the time of delivery to the original purchaser, to be free from defects in material and workmanship when properly set up and operated in accordance with the recommendations set forth by BLUE DIAMOND® ATTACHMENTS, LLC.

BLUE DIAMOND® ATTACHMENTS liability for any defect with respect to accepted goods shall be limited to repairing the goods at a BLUE DIAMOND® ATTACHMENTS designated location or at an authorized dealer location, or replacing them, as BLUE DIAMOND® ATTACHMENTS shall elect. The above shall be in accordance with BLUE DIAMOND® ATTACHMENTS warranty adjustment policies. BLUE DIAMOND® ATTACHMENTS obligation shall terminate twelve (12) months for the 12 ft Flex Wing Tractor Cutter after the delivery of the goods to original purchaser.

This warranty shall not apply to any machine or attachment which shall have been repaired or altered outside the BLUE DIAMOND® ATTACHMENTS factory or authorized BLUE DIAMOND® ATTACHMENTS dealership or in any way so as in BLUE DIAMOND® ATTACHMENTS judgment, to affect its stability or reliability, nor which has been subject to misuse, negligence or accident beyond the company recommended machine rated capacity.

WARRANTY CLAIM

To submit a warranty claim, a claim must be filed with BLUE DIAMOND® ATTACHMENTS before work is performed. The BLUE DIAMOND® PRODUCT SUPPORT TEAM will advise repairs and applicable parts exchanges. Tampering with the failed part may void the warranty. This warranty does not include freight or delivery charges incurred when returning machinery for servicing. Dealer mileage, service calls, and pickup/delivery charges are the customers' responsibility.

EXCLUSIONS OF WARRANTY

Except as otherwise expressly stated herein, BLUE DIAMOND® ATTACHMENTS makes no representation or warranty of any kind, expressed or implied, AND MAKES NO WARRANTY OF MERCHANTABILITY IN RESPECT TO ITS MACHINERY AND/OR ATTACHMENTS ARE FIT FOR ANY PARTICULAR PURPOSE. BLUE DIAMOND® ATTACHMENTS shall not be liable for incidental or consequential damages for any breach or warranty, including but not limited to inconvenience, rental of replacement equipment, loss of profits or other commercial loss. Upon purchase, the buyer assumes all liability for all personal injury and property resulting from the handling, possession, or use of the goods by the buyer.

No agent, employee, or representative of BLUE DIAMOND® ATTACHMENTS has any authority to bind BLUE DIAMOND® ATTACHMENTS to any affirmation, representation, or warranty concerning its machinery and/or attachments except as specifically set forth herein.

This warranty policy supersedes any previous documents.

NOTE: Blue Diamond® Attachments is a trademark of BLUE DIAMOND® ATTACHMENTS



QUALITY | DEPENDABILITY | INTEGRITY

Blue Diamond® Attachments
4512 Anderson Road, Knoxville, TN 37918
888-376-7027